



SDOT Director's Rule 3-2014

Applicant: CITY OF SEATTLE Seattle Department of Transportation (SDOT)	Page 1 of 2	Supersedes: N/A
	Publication:	Effective:
Subject: Street Tree Manual	Code and Section Reference: SMC Section 15.43 Ordinance Number 124166	
	Type of Rule: Legislative	
	Ordinance Authority: SMC 3.12.020	
Index: Street and Sidewalk Use Code; and Technical and Procedural Requirements	Approved	Date
	Proposed	
Scott Kubly, Director of Transportation		

Background

Seattle's street rights-of-way are an important and complex public resource. They must safely accommodate multiple modes of travel, offer universal access around and through the city, provide access to private property, enhance a place's character, and protect environmental resources, including allowing the delivery of trees' environmental services. The Urban Forestry section of Seattle Department of Transportation works collaboratively with various public agencies to coordinate programs to preserve, protect, and promote the increase the urban forest tree canopy within the City's public places and street rights-of-way.

The Street Tree Manual is a Director's Rule that describes the permit requirements for tree planting; pruning, and removals, vegetation management, requirements for Tree Service

Providers, the criteria for tree risk exposure, tree maintenance guidelines, and tree protection requirements for contractors.

This Director's Rule references other City Director's Rules, specifically, the Right of Way Improvements Manual and the City of Seattle's Standard Plans and Specifications. These tools all work to be mutually supportive of the City's infrastructure.

Rule

The Street Tree Manual documents how the City manages trees in the public places. It attempts to provide a comprehensive resource for permit requirements, procedures, standards, and guidelines affecting trees in the street rights-of-way.

The manual can be found online [here \(link\)](#) - and paper copies of the Street Tree Manual are available at the SDOT Street Use & Urban Forestry permit counter 23rd floor of the Seattle Municipal Tower - 700 Fifth Avenue, Seattle Washington.

Attachment: City of Seattle Department of Transportation Street Tree Manual



The Seattle Department of Transportation

STREET TREE MANUAL



CONTENTS

4	Purpose, Intent, and Scope
7	General Overview of Regulations
8	Prohibited Acts and Penalties
10	Street Tree Permitting
12	Street Tree Planting
17	Street Tree Pruning
19	Pruning Guidance
20	Vegetation Management
21	Street Tree Removal and Replacement
24	Tree Service Providers
25	Tree Protection Information for Other Contractors
31	Private Development and Major Utility Projects
32	Heritage Tree Program
33	Additional Resources
34	Glossary of Terms
 APPENDICES	
37	Appendix A: Guidance for Tree Service Selection
39	Appendix B: Street Tree Watering Recommendations
40	Appendix C: Insects and Disease Control
41	Appendix D: Basic Tree Risk Assessment Guide/ Basic Tree Risk Assessment Form
56	Appendix E: Tree Protection Fence
58	Appendix F: Tree Service Provider Registration Form

PURPOSE, INTENT, AND SCOPE

The purpose of this manual is to clarify the intent and scope of the Street Tree Ordinance, updated in the spring of 2013 after more than 50 years. This manual includes information about tree planting, maintenance of trees and other vegetation, and tree protection and preservation that is both required and recommended. The proper care of existing trees supports citywide canopy goals, protects water quality in our streams, lakes, and Sound, enhances public safety and improves the aesthetic qualities of our neighborhoods. Well-maintained trees reflect both the health of the urban forest and the quality of life in our city.

In addition, the City of Seattle is committed to ensuring that during construction and site-development of land that Low Impact Development Principles and Best Management Practices are the standard approach. This manual outlines important practices that must be used during construction and site-development to preserve healthy street trees and other native vegetation and the soil in which they thrive. By protecting these important features of our “Emerald City”, we are reducing stormwater runoff from impervious surfaces and reducing the need for additional impervious surfaces.



On April 29, 2013, the City of Seattle amended *Seattle Municipal Code (SMC 15.43)*, the *Tree and Vegetation Management in Public Places Ordinance* (the *Street Tree Ordinance*), to expand the Seattle Department of Transportation’s (SDOT) regulatory authority to protect, maintain, and preserve trees in public places. For the purposes of this manual, as defined in Chapter 15 of

the Seattle, Municipal Code, ‘public places’ includes public right of way and the space above or beneath its surface, whether or not open or improved, including streets, avenues, ways, boulevards, drives, places, alleys, sidewalks, planting strips, squares, triangles, and plazas that are not privately owned. The following summarizes the code changes:

SMC 15.43	TREE AND VEGETATION MANAGEMENT IN PUBLIC PLACES
Tree Protection	<ol style="list-style-type: none"> 1. Makes it illegal to damage or destroy a street tree. 2. Prohibits topping, spurring, and attaching signs or other objects to trees. 3. Prohibits placement or storage of construction materials adjacent to trees.
Permitting	<ol style="list-style-type: none"> 1. Requires a permit to plant, perform major pruning, or remove a street tree. 2. Describes the permit application process. 3. Defines the criteria for granting or denying a permit application. 4. Requires a replacement tree when a removal permit is granted.
Tree Maintenance Responsibilities	<ol style="list-style-type: none"> 1. Defines responsibilities for street tree maintenance. 2. Gives city authority to perform emergency work on all street trees and trees on abutting property. 3. Defines criteria by which a tree may be declared a public nuisance.
Tree Service Provider Registration Requirements	<ol style="list-style-type: none"> 1. Requires tree service providers performing work on street trees to be supervised by an International Society of Arboriculture (ISA) certified arborist. 2. Documents insurance requirements for tree service providers. 3. Permits a property owner to perform work on street trees in the right of way as long as the work meets industry standards.
Penalties and Fines	<ol style="list-style-type: none"> 1. Establishes penalties for damaging or destroying street trees, which may include fines and/or penalties for the appraised value of the tree, in violation of SMC 15.43.

All trees growing within public places are considered to be street trees, and are protected through the implementation of the *Street Tree Ordinance*.

This manual is designed for property owners, tree service providers, contractors and others who are planning to perform work on, near, or around street trees. This manual does not replace or overrule the current edition of the “City of Seattle Standard

Specifications and Plans for Road, Bridge, and Municipal Construction.” [See: www.seattle.gov/util/Engineering/Standard_Plans_&_Specs/index.htm] The current edition of these municipal plans and specifications is the final authority. This manual is a clarifying accompaniment. If a conflict between this manual and the Standard Specifications arises, the language in the Standard Specifications takes precedence.

Property owners: This manual provides information related to permitting requirements and best practices for maintenance of street trees. This manual also provides guidance on selecting a tree service provider.

Tree service providers: This manual describes the permitting requirements, tree maintenance requirements, and recommendations for maintaining street trees. Prior to performing work on street trees, tree service providers must be registered with SDOT Urban Forestry and possess a Street Use permit.

Contractors: Contractors must comply with tree protection standards for all construction activities or occupations of public places. These standards include required use of tree protection measures when performing work related to common construction and maintenance activities including but not limited to:

- Side Sewer and other utility connection installation and/or repair (both above and below ground)
- Sidewalk or Driveway installation and/or repair
- Scaffold installation and/or material storage
- Any use of public places that may impact street trees

This manual describes mandatory standards and permitting requirements for street trees and the maintenance requirements for vegetation in the planting strip. Requirements are authorized through SMC ordinances and Director's Rules.



Recommended practices are not mandatory unless specifically described as condition of a permit. The manual displays recommended practices in a green shaded area. These recommended practices provide guidance to encourage the use of proactive measures for the care of street trees such as fertilization, mulching, and pest control.

GENERAL OVERVIEW OF REGULATIONS

Key points to understand, with regard to regulations surrounding street trees, include:

- a. A permit is required for any work in public places, including but not limited to tree planting, tree removal, and major pruning.
- b. SDOT Urban Forestry is responsible for permitting and inspecting tree management activities in the public places.
 - The **SDOT City Arborist's Office** is responsible for permitting and inspection of street trees not related to large private or public development projects. Contact: (206) 684-TREE (8733) for general permit-related information.
 - The **SDOT Landscape Architect's Office** is responsible for plan review and inspection of street trees and related urban forestry infrastructure for Department of Planning and Development (DPD) and/or SDOT Street Improvement Permit (SIP) projects to ensure compliance with Land Use code, Stormwater code and the Seattle Green Factor ordinance. Contact: (206) 684-5041 for specific permit-related information.
- c. Maintenance of street trees within public places is the responsibility of the adjacent property owner(s). **The exceptions to this policy are trees specifically designated for maintenance by SDOT Urban Forestry.** These responsibilities include but are not limited to, maintaining the required clearances above the sidewalk and the parking/travel lane of the street. These clearances are located in *Street Tree Planting* section of this manual.

To confirm the maintenance responsibilities for street trees, SDOT has developed a street tree map, posted online at web6.seattle.gov/SDOT/StreetTrees/. To access the information, enter

your address into the upper left search field. Most trees have a unique identifying number. When applicable, reference this number in your tree pruning, planting or removal/replacement permit application.

- d. Tree service providers are required to comply with SMC 15.43.050 by registering with SDOT Urban Forestry. The tree service provider registration application is located at www.seattle.gov/transportation/treecompanypermits.htm.
- e. All contractors are required to follow the specific instructions associated with the street use permit; the tree protection measures outlined in this manual; and directives provided in the latest version of the "City of Seattle Standard Plans and Specifications for Municipal Construction."

SDOT Seattle Department of Transportation
 Street Use & Urban Forestry Division
 700 Fifth Avenue, Suite 2000, PO Box 34996
 Seattle, Washington 98124-2096
 (206) 684-5231 (206) 684-TREE
sdot.seattle.gov

URBAN FORESTRY PERMIT APPLICATION
 Seattle Municipal Code (SMC) 15.04.15.42

SDOT Permit Number(s) (Initials)
 Make
 Review
(Collectible Only)

1 ATTACH STREET USE GENERAL APPLICATION
 My signature indicates that I am bound by the terms and conditions outlined in Section 2 of the Street Use General Application.
 APPLICANT SIGNATURE DATE

2 PROJECT ADDRESS
 Address Number Street Name (include NE, SW, Ave, St, Blvd, etc.)

3 WORK DESCRIPTION

Tree Work Type	Number of Trees Affected	Species	Desired Start Date	Documentation Required
<input type="checkbox"/> Pruning (1A)				• Tree Pruning Checklist (page 4 of this document) • Site Diagram (page 3 of this document)
<input type="checkbox"/> Planting (1B)				• Site Diagram (page 3 of this document)
<input type="checkbox"/> Removal (1C)				• Site Diagram (page 3 of this document)
<input type="checkbox"/> Unapproved Right of Way (1D)				• Site Diagram (page 3 of this document) • Square footage impacted <input type="text"/> (sq. ft.)

4 EXISTING SITE INFORMATION (Answer if applicable)
 Will you be working in an area that is next to your property or in front of your property? Yes No
 Will work occur along multiple streets or frontages? Yes No
 Additional street/frontage where work will occur (street name)
 Additional street/frontage where work will occur (street name)

Page 1 of 4

PROHIBITED ACTS AND PENALTIES

The following list of terms describes actions that are subject to penalties. In addition to performing any of these actions, failure to obtain a permit or failure to follow the conditions of a permit, this manual or the Seattle City Ordinance may also lead to penalties. **The Glossary of Terms in this manual contains definitions of terms that are commonly used in the Urban Forestry and Arboricultural industries. Some commonly used words in general use may have broad meaning, but in the context of this manual can have a very specific meaning that could affect how you approach a project. It is important to be familiar with these terms as these determine the criteria by which SDOT will enforce the standards described in this manual.**

- a. Causing or encouraging a fire underneath or within five feet of the dripline of a street tree or, within five feet of other vegetation in public places
- b. Applying toxic chemicals to a street tree or to the ground within the dripline of the street tree.
- c. Attaching any rope, wire, nails, advertisements, posters or other objects to any street tree, except for supports for young or broken trees, official City placard affixed in a manner that is not injurious to the trees, or attaching decorative or seasonal lighting attached in a manner consistent with SDOT specifications and does not permanently damage the street tree or impact mobility.
- d. Using climbing spurs on a street tree.
- e. Causing the topping or severe crown reduction of a street tree, except in the course of tree removal pursuant to a Street Use permit as approved by the Director.
- f. Placing or storing materials, including but not limited to, stones, bricks, concrete, asphalt, fill soil, plastic sheeting, or construction materials, within the dripline of a street tree or other vegetation in public places.



- g. Injuring Street Trees: Taking any action predictably leading to the premature death of a street tree or permanent damage to its health, including but not limited to: root cutting, girdling, or unauthorized pruning or work within the dripline of street trees including trenching, excavating, grade alteration, paving, or material storage.
- h. Excessive Pruning: Removing more than 1/4 (25 percent) of the functioning leaf, stem, or root area. Pruning in excess of 25 percent may be injurious to the tree and is a prohibited act (SMC 15.43.020).

- i. Topping: means the severe and indiscriminate cutting back of limbs to stubs within the tree's crown, to such a degree as to remove the normal canopy and disfigure the tree; or the cutting back of limbs or branches to lateral branches that are not sufficiently large enough to assume the terminal role, or are less than ½ of the diameter of the limb or branch that is cut. This practice is also known as stubbing, tipping, heading, hatracking, dehorning or excessive canopy reduction.

The above list is not to be considered a complete list of prohibited acts. The overall prohibition includes destroying, killing, mutilating, or defacing a street tree in any manner or by other means not listed above.

Citations (SMC 15.91): SDOT may issue a citation when work is performed on a street tree without first obtaining a Street Use permit. The penalty for failure to obtain a permit is \$500 for the first offense and \$1,000 for each subsequent offense. The penalty for noncompliance with permit conditions is \$250 for the first offense and \$500 for each subsequent violation.

Notices of Violation (SMC 15.90.018.B): SDOT may issue Notices of Violation for violation of any provisions of SMC 15.43. Violations are subject to a cumulative penalty of up to \$500 per day until compliance has been achieved. In addition to the daily fine for non-compliance, any person who destroys, kills, injures or mutilates a street tree may be fined the appraised value of each affected tree as determined by the most current edition of the Council of Tree and Landscape Appraisers "Guide for Plant Appraisal. If the violation is found to be willful or malicious, the amount of the penalty may be trebled.

STREET TREE PERMITTING

Property owners are responsible for maintaining the trees on their own property, which may impact the public place and any street trees adjacent to their property not identified as city-maintained

Street Use Permits are required for the following activities:

Planting: Only tree species identified in the SDOT's approved tree list or trees approved by the Director may be planted in public places. Tree spacing and clearance requirements from other infrastructure are outlined in this manual in the section on *Street Tree Planting*.

Major Pruning: Major pruning means removal of branches two inches in diameter or greater; removal of roots two inches in diameter or greater; or removal of branches constituting more than 15 percent of a tree's foliage-bearing area. All major pruning of street trees shall comply with American National Standards Institute (ANSI) A-300 standards and relevant standards outlined in this manual in the *Street Tree Pruning* section.

Removal: The City's policy is to retain and preserve street trees whenever possible. Accordingly, street tree removal shall not be permitted unless the Director determines that a street tree:

1. Is a hazardous tree;
2. Poses a public safety hazard;
3. Is in such a condition of poor health or poor vigor that removal is justified; or
4. Cannot be successfully retained due to public or private construction or development conflicts.

Street trees permitted for removal shall be replaced with a species of tree from the approved tree list or with a tree approved by the Director. Replacement trees shall be planted consistent with the standards in this manual if site conditions allow.

Tree Service Providers: In addition to obtaining a Street Use permit, all tree service providers must be registered with SDOT Urban Forestry. See the *Tree Service Providers* section for registration requirements.

If you plan to have work done on private property, be sure to see the section on *Private Development and Major Pruning Permits*. This may include sidewalk repair, trenching, tunneling, or work involving heavy equipment near street trees.

Permit Applications: Permit applications are available from the SDOT Street Use & Urban Forestry permit counter located on the 23rd floor of the Seattle Municipal Tower, 700 Fifth Ave, Seattle, WA. The application process often requires a site visit. Approved permits have conditions and other requirements that must be followed. Permittees must maintain the approved permit on the jobsite at all times.

Permit Applicant: if you are considering hiring a tree service provider, you may want to review Appendix A: Guidance for Tree Service Selection, under the Additional Resources section of this manual.

Individuals who have obtained other Street Use Permits related to construction in the Right of Way must still obtain a separate permit for planting, performing major pruning, and removing street trees.

Plans: The permit application provides a template for a site plan and pruning plan. Identify the location of

the specific trees and the nearby utilities on the site plan. An application for pruning permits requires a completed pruning plan. Additional information will be required if mobility impacts would result from the proposed work. For specifics on traffic control plans, see CAM 2111 - www.seattle.gov/transportation/stuse_docs.htm

THE FOLLOWING CHART SUMMARIZES PERMIT AND PLAN REQUIREMENTS:

USE CODE	PERMIT REQUIRED?	SITE PLAN REQUIRED?	PRUNING PLAN?	CERTIFIED ARBORIST REQUIRED?	OTHER PERMIT CONSIDERATIONS
1A Major Pruning	Yes, For Major Pruning – 2 inches or greater, branches or roots or more than 15% of foliage volume.	Yes, if there are mobility impacts	Yes	Yes, if a tree service provider is performing the major pruning	<ul style="list-style-type: none"> • Mobility Impacts*
1B Planting	Yes	Yes	No	No	<ul style="list-style-type: none"> • Use the SDOT Approved Tree List • Mobility Impacts
1C Removal	Yes	Yes	No	Yes, if a tree service provider is performing the removal	<ul style="list-style-type: none"> • Requires professional evaluation • Requires a public notice • Replacement requirement • Special conditions for emergency tree removal • Mobility Impacts
1D Unimproved right of way	Yes, Pruning, removal, maintenance in unopened right-of-way	Yes	Yes	Yes, if major pruning or removing trees	<ul style="list-style-type: none"> • Requires plan review and inspection deposit

***Mobility impacts** are considered to be any impediment to free travel on the City’s rights-of-way. This includes pedestrians, bicycle travel, and vehicle travel. If there are mobility impacts with a project, these need to be described in full on the permit application. Depending on the location, extent of the work and the timing of the permit activities, a traffic control plan may be required. For specifics on traffic control plans, see CAM 2111: www.seattle.gov/transportation/stuse_docs.htm

Approved permits will include site-specific requirements and best management practices that must be followed for the duration of the project.

STREET TREE PLANTING

TREE SELECTION AND SPACING

Only tree species identified in the SDOT's approved tree list or trees approved by the Director may be planted in public places as street trees. This *SDOT Approved Street Tree List* (www.seattle.gov/transportation/docs/uf/2011-Street_Tree_List.pdf) identifies those trees that are suitable for planting under power lines, as well as the minimum planting space necessary for each species. Only trees identified for use under power lines per the *SDOT Approved Street Tree List* shall be permitted underneath primary voltage power lines.

Guidance for street tree spacing along improved rights-of-way is noted below:

Tree spacing is a function of crown spread with the following as general guidance (see the *Approved Street Tree List*)

Small Trees	20 to 25 feet on center
Small/Medium Trees	25 to 30 feet on center
Medium/Large Trees	30 to 35 feet on center
Large Scale Trees	35 to 40+ feet on center

Columnar varieties may be spaced more closely if approved by SDOT Urban Forestry



Standard Clearances between trees and other infrastructure are necessary to minimize conflict with objects in public places. Clearance requirements are outlined in the table below. The clearances described below are from and follow the most recent version

of the SDOT Right of Way Improvements Manual and the Municipal Plans and Specifications. Compliance is required; deviations from these street tree clearances are allowable only with specific approval.

VERTICAL CLEARANCES: TREE CANOPY ABOVE SURFACES

FROM	TO	STANDARD CLEARANCE (DISTANCE)
Sidewalk	Any horizontal projection over the named surface	8 feet
Roadway surface	Tree limbs (other infrastructure requires more clearance)	14 feet
Bicycle path surface	Any horizontal projection over the named surface	10 feet

LATERAL CLEARANCES: TREE PLANTING ADJACENT TO OTHER INFRASTRUCTURE

FROM	TO	STANDARD CLEARANCE (DISTANCE)
From tree centerline	Face of curb	3.5 feet
From tree centerline	Sidewalk or sidewalk landing	2 feet
From tree centerline	Driveway (measured from the edge of driveway at the sidewalk)	7.5 feet
From tree centerline	Edge of streetlight poles	20 feet
From tree centerline	Edge of fire hydrants	5 feet
From tree centerline	Edge of utility poles	10 feet
From tree centerline	Underground utilities	5 feet (except for ducts and gas pipes as shown on Seattle Standard Plan 030)
From tree centerline	Roadway edge where no curb exists	10 feet

Trees shall be planted according to Standard Plan 100a. Deviations from the Standard Plan 100a must be approved by SDOT Urban Forestry.

PLANTING STOCK AND MATERIALS

Tree Quality: Trees approved for the right of way should meet industry standards for nursery stock,

to provide root and canopy development to support healthy, vigorous growth with natural resistance against disease and/or pest infestation. Trees with broken or inappropriately pruned tops, injured trunks, or branch damage that cannot be corrected by minor pruning are not suitable as street trees. For more information on industry standards, and how to select

NOTES:

1. PLANTING INCLUDES REMOVAL OF STAKES ONE YEAR AFTER INSTALLATION.
2. SHAPE SOIL SURFACE TO PROVIDE 4' DIA WATERING RING.
3. TREE CLEARANCE SHALL BE PER STD PLAN NO 030.
4. SEE STD PLAN NO 424 FOR TREE PIT DETAIL.
5. ADJUST TREE TIES DURING ESTABLISHMENT TO ALLOW ROOM FOR GROWTH (@1" SLACK).
6. ROOT BARRIER REQUIRED ALONG EDGE OF ROADWAY, CURB, DRIVEWAY, TRAIL, SIDEWALK, OR OTHER STRUCTURES WHERE ROOTBALL IS WITHIN TWO FEET; PLACE VERTICAL ROOTBARRIER AS SHOWN IN STANDARD PLANS NO 424a OR 424b. INSTALL ROOT BARRIERS FOR NEWLY PLANTED TREES ONLY.

STAKE TREE WITH (2) TREATED 2"Ø LODGEPOLE PINE DOWELED TREE STAKES (8'-0" LENGTH) LOOP EACH TIE AROUND HALF TREE LOOSELY TO PROVIDE 1" SLACK FOR TRUNK GROWTH.

"CHAINLOCK" OR EQUAL TREE TIE MATERIAL (1" SIZE) NAIL OR STAPLE TREE TIE MATERIAL TO STAKE TO HOLD VERTICALLY. LOOP EACH TIE AROUND HALF TREE LOOSELY TO PROVIDE 1" SLACK FOR TRUNK GROWTH.

2"-3" MULCH DEPTH (TAPERED AT TRUNK)

MULCH TREE PIT MIN 5'-0" LENGTH X FULL PLANTING STRIP WIDTH BETWEEN CURB AND SIDEWALK (FOR PLANTING STRIPS LESS THAN 6'-0" WIDE) OR PROVIDE 5'-0" DIA MULCH RING FOR PLANTING STRIPS WIDER THAN 6'-0".

SIDEWALK

18" ROOTBARRIER AT SIDEWALK.

ROUGHEN SIDES OF PLANTING HOLE MAXIMIZE EXCAVATED AREA WITHOUT UNDERMINING ADJACENT PAVING/CURB.

ROOTBARRIER; PLACE AT EDGE OF PAVEMENT/SIDEWALK/ETC.; PLACE PRIOR TO PLACEMENT OF NEW SIDEWALK OR CURB TO PREVENT UNDERMINING.

SEE STD SPEC SECTION 8-02.3(6)B, OR AS APPROVED BY ENGINEER.

REMOVE ALL WIRE, STRINGS, AND OTHER NON-BURLAP MATERIAL; AND REMOVE BURLAP FROM TOP 2/3 OF ROOTBALL MINIMUM. REMOVE ENTIRELY WHEN DIRECTED BY THE ENGINEER.

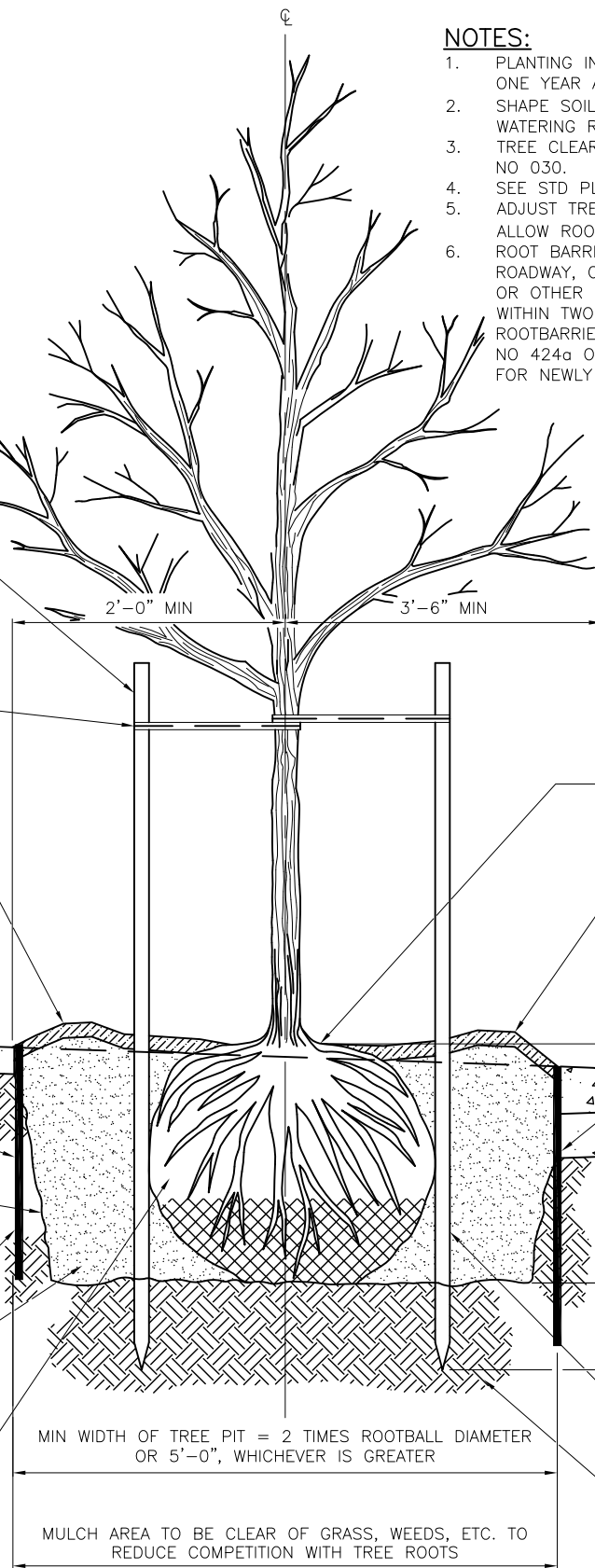

SET TOP OF ROOT CROWN 2" ABOVE ADJACENT CURB & SIDEWALK GRADE.

3" TO 4" HIGH WATERING RING (SEE NOTE 2)

24" ROOTBARRIER AT CURB WHEN SHOWN ON THE DRAWINGS.

TREE PIT DEPTH = ROOTBALL DEPTH (MEASURE BEFORE DIGGING TO AVOID OVEREXCAVATION).

DRIVE STAKES 6" TO 1'-0" INTO UNDISTURBED SOIL BELOW ROOTBALL.

DRIVE STAKE AT ROOTBALL EDGE (TYP)(SEE NOTE 1)

UNDISTURBED SUBGRADE (PROVIDES FIRM BASE SO THAT ROOTBALL WILL NOT SINK).

MIN WIDTH OF TREE PIT = 2 TIMES ROOTBALL DIAMETER OR 5'-0", WHICHEVER IS GREATER

MULCH AREA TO BE CLEAR OF GRASS, WEEDS, ETC. TO REDUCE COMPETITION WITH TREE ROOTS

REF STD SPEC SEC 8-02



City of Seattle

NOT TO SCALE

**DECIDUOUS TREE PLANTING
IN PLANTING STRIP**

quality trees from local suppliers, see the additional resources links at the end of this manual.

Soil Amendments: Soil amendments such as compost or other soil conditioners are typically included as a standard for construction projects that construct new planting strips. Soil amendment is not required nor recommended for street tree installations in existing planting strips with well-developed soil and appropriate site and soil properties for drainage.

Standard tree planting site should be excavated to a depth equal to the depth of the rootball with circumference a minimum of 24 inches greater than the root ball diameter. Excavated native soil should be placed as backfill free of debris, weeds, sod and rocks larger than 2 feet.

Root ball Handling and Placement: Trees should be handled to ensure protection and full support under the root ball, placed with the root crown two inches

above adjacent curb and sidewalk surfaces, and oriented to align structural branches for optimum compatibility with buildings and adjacent street/sidewalk clearances.

Twine, burlap and wire baskets should be removed to expose the top 2/3 of the root ball (minimum). Full removal of twine, burlap and wire baskets is preferred. All other containers, grow bags and materials used in the commercial production of nursery stock must be removed entirely from the root ball. Roots should be pruned, loosened and/or straightened to ensure proper growth and establishment.

Mulch Topdressing: Coarse untreated wood chips 1/2 inch to six inches in size; free of weeds, weed seed and invasive plants should be applied as shown in Standard Plan 100a. NOTE: Proper installation and ongoing management of mulch topdressing is necessary to retain soil moisture and protect trees from damage by lawn maintenance equipment.



Tree Stakes and Ties: Tree stake and tie installation should be installed for one year only, and installed as outlined in Standard Plan 100a unless otherwise approved by SDOT Urban Forestry. Staking provides stability until the tree is well established, but also serves as some protection against lawn mower damage and vandalism.

Backfilling: Place backfill soil around root ball, lightly compacting the soil with pole or shovel handle to eliminate voids. Construct a watering ring (soil berm at three-four inches; height x four inch diameter) and water thoroughly to ensure settlement of the backfill material.

AFTER PLANTING CARE (ESTABLISHMENT)

Watering: Establishment watering is necessary for the survival of new street trees. Monitor and water trees weekly during summer months and especially during drought conditions to ensure adequate watering frequency suited to the tree species and soil conditions. The minimum watering requirements for dry months is five gallons of water per one-inch diameter per week. For some projects, a watering schedule will be required as outlined in the manual of Standard Specifications. Commercially available watering bags are recommended for efficient use of water and labor and effective application for the first three growing seasons following tree installation. Additional recommendations and descriptions of acceptable practices for street tree watering are found in Appendix B.

Weed Control / Mulch Restoration: Weed removal (2-3 times) during the active growing season and routine (annual) mulch restoration of mulch topdressing is necessary to retain soil moisture. Mulch restoration protects trees from damage by lawn maintenance equipment—a common cause of tree failure.



Establishment Pruning: Limit pruning during establishment to removal of sucker growth at the base of trees and removal of dead branches for optimum canopy and root development. This management activity is encouraged and does not require a permit. There is more information on this subject in the *Street Tree Pruning* section of this manual.

INSECT AND DISEASE CONTROL

Generally, insect populations do not threaten tree health to the point of mortality. More often, when their populations become too great they create a nuisance. SDOT may require insect control by the property owner in cases where insects or disease and related tree decline may result in the death of a street tree, based on a tree risk assessment. Additional recommendations and descriptions of acceptable practices for insect and disease control are found in Appendix C.

STREET TREE PRUNING

SDOT regulates pruning of street trees with an emphasis on public safety and tree health and longevity. Pruning to achieve standard clearances as outlined in this manual is the first objective of a street tree pruning project. Street tree pruning should minimize structural defects and encourage natural growth, maximizing tree canopy in the space available.

All maintenance performed on street trees shall be in accordance with plans developed by using the most current edition of the following industry standards and supervised by an ISA certified arborist or ISA certified tree worker when work is performed by a tree service provider. All pruning or removal plans must have stated objectives, followed by procedures indicating how the objectives will be achieved.

The reference for these standards is the *Standard Practices for Tree Care Operations – American National Standards Institute (ANSI) A300-(Part 1)*.

Copies of these *Standard Practices for Tree Care Operations* are available for purchase through TCIA or ISA:

Tree Care Industry Association

136 Harvey Road, Suite 101
Londonderry, NH 03053

www.tcia.org

Phone: (603) 314-5380

Toll-free: (800) 733-2622

International Society of Arboriculture

PO Box 3129

Champaign, IL 61826

www.isa-arbor.com

Phone: (217) 355-9411



PRUNING REQUIREMENTS

Abutting property owners are required to prune street trees to achieve compliance with existing vertical clearance standards as shown in the Tree Selection and Spacing portion of the *Street Tree Planting* section of this manual. Pruning to meet ROW clearance standards shall also include work to minimize obstructions with other transportation infrastructure (streetlights, traffic signals, signs, etc.) while ensuring the health and natural growth habit of the street tree. Abutting property owners are required to obtain a permit if the pruning constitutes major pruning. No permit is required for minor pruning.

Any person intending to perform major pruning of a street tree must obtain an SDOT Street Use permit prior to performing the work. Major pruning is defined as:

Removal of branches two inches in diameter or greater; removal of roots two inches in diameter or greater; or removal of branches constituting more than 15 percent of a tree’s foliage bearing area.

Applications for an SDOT Street Use permit to perform major pruning must include a pruning plan and be submitted with the Street Use permit application. The plan must be approved by SDOT. The

pruning plan must comply with the minimum Right of Way clearance standards and the following major pruning standards:

Maximum Pruning Allowed: SDOT Urban Forestry will evaluate maximum pruning on an individual tree basis. No more than ¼ (25 percent) of the functioning leaf and stem area may be removed within one calendar year on any street tree. Foliage pruning may not remove branches or limbs to a degree that would cause the tree to be physically or aesthetically unbalanced. Trees are individual in form and structure, and pruning needs may not always fit strict rules. The permit applicant shall assume all responsibility for special pruning practices that vary from the standards outlined in this manual. A pruning plan submitted at the time of permit application shall demonstrate that the proposed work conforms to the maximum pruning guidelines described here:

Types of Pruning: There are six types of pruning that may be performed on mature Street trees. Prior to performing major pruning, the tree worker is required to be familiar with these types of pruning as defined and described in *ANSI A300 (Part 1): Standard Practices for Tree, Shrub, and Other Woody Plant Management*. The pruning plan submitted at the time of permit application shall use these terms to describe the proposed work.

Crown Cleaning	The removal of dead, dying, diseased, crowded, weakly attached, low-vigor branches, and water sprouts from a tree crown.
Crown Thinning	The selective removal of branches to increase light penetration and air movement, and to reduce weight.
Crown Raising	The removal of the lower branches of a tree in order to provide clearance.
Crown Restoration	Crown restoration pruning should improve the structure, form, and appearance of trees that have been severely headed, vandalized, or storm damaged.
Crown Reduction	The reduction of the top, sides, or individual limbs by the means of removal of a leader or longest portion of a limb to a lateral no less than one-third of the total diameter of the original limb removing no more than one-fourth of the leaf surface.
Utility Pruning	The removals of branches to prevent the loss of utility service, prevent damage to equipment, avoid impairment, and uphold the intended usage of the utility space. Only a qualified line clearance tree trimmer or qualified line clearance tree trimmer trainee should perform this work.

PRUNING GUIDANCE

PRUNING YOUNG TREES

The average life expectancy for trees growing in harsh urban conditions is much shorter than if the tree is growing in ideal conditions. Pruning trees early will improve life expectancy and is a proven, cost-effective measure to prevent costly intervention in the future. Well-timed and careful pruning results in safer trees with fewer branch failures.

- Should be pruned during the second or third year after planting to improve their structure, and only minor crown cleaning every 3-7 years thereafter. Refer to ISA Tree Pruning Guidelines for more detailed information: www.treesaregood.com/treecare/pruning_young.aspx
- Do not top the main leader.
- Select permanent branching and allow temporary low branching on the lowest part of the trunk to remain. Main branches should eventually be spaced at least 18-inches apart to alleviate a tight grouping of branches.

TIMING OF PRUNING

To reduce the probability of insect infestation, disease or infection:

Pine (*Pinus* spp.) or Elm (*Ulmus* spp.): Do not prune May-October to reduce possible exposure to bark beetle (pine) or Dutch Elm Disease (elm)

Other considerations:

Avoid pruning during the flush of spring shoot growth and during fall, prior to dormancy

Trees with thin bark: Do not prune in summer when sun scald injury may be a factor

Deciduous trees (leafless in winter): Best pruned November-February, but can be pruned any time throughout the year for safety-related issues.

Distressed trees require as much leaf area as possible to overcome stressed conditions. To avoid additional injury, the following measures may be followed for these trees:

- **Injury or Disturbance:** If a tree has been damaged by injury or disturbance, delay pruning until deadwood becomes evident (typically 1 to 3 years after injury). Crown cleaning is recommended in these cases.
- **Neglect:** Trees that have received little or no care or maintenance may need moderate crown thinning, reduction of end weights or entire crown restoration.

Hazardous trees of any species may be pruned any time of the year for risk abatement reasons.

VEGETATION MANAGEMENT

Gardening in planting strips: A street use permit is not required for growing food crops in the planting strip. The guidelines offered in CAM 2305 (see: www.seattle.gov/transportation/stuse_docs.htm) must be followed in regards to gardening activities in the planting strip. Street tree removal will not be permitted to accommodate gardening activities.

Vegetation Management at intersections: any groundcover, shrub, grass or other vegetation shall be maintained not to exceed two feet in height within 30 feet of the curb line of the intersecting street (see image below), or within 20 feet of a legal crosswalk. Lower limbs on street trees within thirty feet of an intersection shall be pruned to a minimum of eight feet over the sidewalk and planting strip, and 14 feet

over the surface of the street, according to section 4.14.2 of the SDOT Right of Way Improvements Manual (see: www.seattle.gov/transportation/rowmanual/manual/).

If SDOT Urban Forestry determines that a tree on private property poses a threat to the safety of the public place, or is infected with a contagious disease, which threatens the health of trees in public places; or if vegetation is determined to be a nuisance as defined by SMC 15.04.012. SDOT Urban Forestry will work in cooperation with the Director of Planning and Development to enforce SMC 10.52.020 and 10.52.030, and require the property owner to address the situation in a manner as to remove the threat.



STREET TREE REMOVAL AND REPLACEMENT



A street tree must be protected and preserved unless SDOT has issued a Street Use Permit authorizing the removal and replacement of the tree. Street trees that are removed must be replaced with the same species, or another species that provides comparable or greater canopy coverage at maturity, providing that the planting site has sufficient space to support the replacement tree. Removal of a street tree without a permit or without replacing the tree is a violation of City ordinance and subject to penalty.

A street tree may not be removed unless SDOT determines that:

- The street tree is a hazardous tree and cannot be relieved of its hazardous condition through actions other than removal;
- The street tree poses a public safety hazard. In some cases, an otherwise healthy tree may have grown in such a way that it is not compatible with the safe operation of the transportation system. A native tree, germinating naturally and growing into the clearance zone required at an arterial intersection is one example;
- The street tree is in such a condition of poor health or poor vigor that removal is justified; or
- The street tree cannot be successfully retained, due to public or private construction or development conflicts. The conflict must be confirmed and removal approved by SDOT Urban Forestry.

In all cases, a tree removal permit application requires the following for City review and approval, unless specifically waived by SDOT Urban Forestry:

1. Completed SDOT Street Use General Permit Application
2. Completed SDOT Urban Forestry Permit Application
3. Payment of any fees associated with administration of the permit, occupation or use of the right-of-way
4. Verification of neighborhood notification or tree posting.
5. Arborist report, if needed to document the existence of a hazard.

All street trees that have been assessed and approved by SDOT for removal, including emergency removals, are subject to *Tree Replacement Standards* (below). With the exception of emergency removals, a copy of the permit must be on site during the removal process. See section on *Emergency Removal Conditions* for more information about emergency conditions.

The removal permit must be on site during the removal process. Street tree removal processes may involve significant impacts to mobility within the improved right of way. In some instances, traffic control plans may be required, and review fees apply.

ARBORIST REPORT

SDOT Urban Forestry may require an Arborist Report be submitted in support of a street tree removal permit application. The Arborist Report must be prepared by an ISA Qualified Tree Risk Assessor and shall include the following:

- A completed ISA Tree Evaluation Form – see *Appendix D*
- A brief letter that includes:
 - Arborist’s name and certification number
 - Site address and date of inspection
 - Description of inspection methods used to identify defects
 - Description of the defect/s that contribute to the tree’s risk
 - Explanation of alternative risk reduction options considered in lieu of removal
- Up to 6 photographs that clearly depict the defects and/or tree condition

SDOT Urban Forestry retains discretionary right to approve, request in writing a second opinion of a rating in writing, or recommend action to mitigate the risk, short of tree removal.



For more information regarding the Tree Risk Assessment process, see *Appendix D*

TREE REMOVAL POSTING REQUIREMENTS

Before a street tree is permitted for removal, a yellow **Tree Removal and Replacement** notice or safety orange **Tree Removal** notice is required. Placards are provided by SDOT and must be posted a minimum of 14 calendar days prior to removal as a condition of permit issuance.

Tree Removal

City of Seattle

Public Notice

Tree to be removed and replaced

Type of Tree: Species

Reason(s) for removal:

- **Specific reasons for removal are listed here. Per SMC 15.43.030 C – Trees may be removed if they are Hazardous – Pose a Public safety hazard that cannot be corrected by any other means than removal – Are in such poor health or vigor that removal is justified – Cannot be successfully retained due to public or private construction activities.**

This Notification Posted On: _____

Inspected by: _____

Please direct comments to:
City Arborist – Seattle Municipal Tower
P.O. Box 34996 Seattle, WA 98124-4996
Seattle.Trees@Seattle.gov (206) 684-TREE (8733)

TREE REPLACEMENT STANDARDS

When a street tree is removed, tree replacement is required. When a street tree is to be replaced on site, the following standards apply:

- Tree replacements shall be the same species, or a species that provides comparable or greater canopy coverage at maturity, unless otherwise approved by SDOT Urban Forestry.
- Tree replacements shall be planted in the same location as the tree removed unless otherwise approved by SDOT Urban Forestry.

Where planting space is not adequate to support replacement planting on the original site, alternative conditions may apply to achieve an appropriate balance for the loss of public investment and/or benefit. Conditions for replacement are based on assessment of trees and sites on a case-by-case basis.

HAZARD TREE MANAGEMENT

In addition to the maintenance responsibilities for adjacent street trees, the owner of trees on property abutting public places or the resident of the property has an obligation to maintain their trees so that they do not create a hazard to the public using public places. If a hazard to the public should develop, the owner is required to place barricades in public places to warn the public of the danger and discourage entry into the area of risk. Upon discovering the hazard, the owner shall immediately inform the Director of Planning and Development, and, the Director of Transportation. For hazards along Park drives and boulevards, the Superintendent of Parks and Recreation should be alerted, and as to other public places, the Director of Transportation.

TREE RISK REDUCTION; ALTERNATIVES TO REMOVAL

Public safety risk associated with street trees is best managed with regular inspection and timely maintenance actions initiated by the property owner and their registered Tree Service Provider.

Reduce the potential for risk by planting trees that are not problematic and that fit the site. SDOT Urban Forestry has developed an *SDOT Approved Street Tree List*.

A healthy, vigorous tree that receives regular care is less likely to develop hazardous conditions than one that is ignored. Prevention is the best solution to avoid risk associated with trees.

The risk posed by a tree may be reduced by removing dead and broken branches, reducing branch end weights, by mechanically supporting weak branches from below, or by cabling and bracing.

In some cases, targets may be removed such as by moving picnic tables or other items beneath a precarious tree, fencing to prevent access to such trees, or rerouting pedestrian or vehicular traffic.

If there are no other options to abate the hazard, the tree may need to be removed. Steps outlined in this section of the manual should be followed as soon as possible to initiate review by SDOT Urban Forestry.

EMERGENCY REMOVAL CONDITIONS

When a street tree is in a condition that poses an imminent threat to the public place, and no other risk abatement options exist, the tree may be removed without prior City review or approval. **In such instances, contact SDOT's 24-hour Emergency Dispatch at (206) 386-1218 to notify SDOT of the intended action.**

In emergency removal cases, the property owner or tree service professional must substantiate conditions for removal after the action. Sufficient documentation includes photographs, tree condition information, or other relevant information and completion of a Street Use permit application for tree removal and replacement. An *Arborist Report* is the preferred format. This information is to be submitted to the City Arborist within 24 hours, or next business day of the emergency removal. All other authorizations are subject to the standard procedure outlined in *Tree Removal*.

Tree replacement is required for all tree removals, unless specifically waived by SDOT Urban Forestry.

TREE SERVICE PROVIDERS

Tree service provider registration is available at no cost through SDOT Urban Forestry. The names of registered Tree Service Providers are available on the SDOT Urban Forestry webpages.

If you are a tree service provider, it is your responsibility to read and understand this manual.

REGISTRATION REQUIREMENTS FOR TREE SERVICE PROVIDERS

Tree Service Providers (SMC 15.43.050): Code requires that any contractor who performs pruning on street trees register as a tree service provider. SDOT Urban Forestry maintains an online registry of tree service providers who meet the requirements described below. Contractors who are able to meet the following criteria are eligible to register:

- Have a State of Washington General Contractor's License
- Have a City of Seattle Business License
- Provide proof of commercial general liability (CGL) insurance that names the City of Seattle as an additional insured for primary limits of liability, with a minimum of \$1,000,000 in coverage (see Client Assistance Memo 2102)

- Identify at least one employee who is a credentialed ISA certified arborist or ISA Certified Tree Worker who is responsible for supervision of street tree pruning
- Affirm that the Tree Service Provider has read and understands the following documents:
 - *Street Tree Ordinance (Ord. # 124166)*
 - *Street Tree Manual*
 - *ANSI – A-300, Pruning Standards*, and
 - *City of Seattle Traffic Control Manual for In-Street Work*

Registration: Complete registration in person at the SDOT Street Use & Urban Forestry permit counter, floor 23 of the Seattle Municipal Tower, 700 5th Avenue in Downtown Seattle. This public counter is open Monday, Tuesday, Wednesday, and Friday from 8:00 AM to 5:00 PM and Thursday from 10:30 AM to 5:00 PM. Registration can also be completed online, www.seattle.gov/transportation/treecompanypermits.htm.

TREE PROTECTION INFORMATION FOR OTHER CONTRACTORS

TREE PROTECTION AND PRESERVATION - INTRODUCTION

Street trees shall be retained and protected from incidental impacts, injury, and damage by permitted or unpermitted construction or use of space in the right-of-way. The following requirements come from the City of Seattle's Right-of-Way Improvements Manual, Chapter 4.14 that describes the City's regulations for the installation of any improvements into the public place. The engineering standards come from City of Seattle Standard Plans and Specifications for Municipal Construction. All permittees are required to follow these plans and specifications whenever there is work in the City's rights-of-way.

To prevent injury to street trees, no work may occur within a street tree's critical root zone (CRZ or 'Zone A') without specific authorization from SDOT Urban Forestry. Work within the dripline ('Zone B') of a street tree requires that specific actions be taken to ensure that the tree, its roots, and the soil are protected from construction damage. Construction activities in these zones affect both the tree's canopy and the tree's roots, and adequate protection measures are required to protect street trees from damage.

Each street tree within a work zone that is not approved for removal shall be fenced, including all unpaved areas of the critical root zone to prevent compaction, grading or other disturbance. See Tree Protection Fencing detail at the end of this section of the manual. The critical root zone must be shown on all site plans for the permitted activity. Improvements or activities such as removal of pavement, repair of pavement, new paving, utility, and irrigation trenching and other ancillary activities shall occur outside the critical root zone, unless authorized by SDOT Urban Forestry. See Standard Plan 133 drawing below for a depiction of the required critical root zone protection area.

CALCULATING THE TREE PROTECTION ZONES

City of Seattle Standard Plan 133 is included here to demonstrate the calculations of the Critical Root Zone and the dripline. These zones may have different protection requirements, it is important to understand how these zones and requirements work together. Although Standard plan 133 demonstrates below grade tree protection areas, protection of tree canopy and branches is also required.

ZONE A is the Critical Root Zone (CRZ) of the tree.

Typical trees: CRZ radius equals $\frac{1}{2}$ of the dripline radius

Columnar trees: CRZ radius equals six inches for every inch of trunk diameter measured at 54 inches above grade

For small or columnar trees, the physical dripline may be equal to or smaller than the CRZ. **The CRZ can never be less than four feet in radius.** This is the minimum standard requirement.

No work may occur in or occupy CRZ without first contacting Urban Forestry.

Fencing Requirements: The designated CRZ must be fully fenced, excluding the paved surfaces.

NEXT PAGE:
STANDARD PLAN NO. 133: TREE PROTECTION-CRITICAL ROOT ZONE

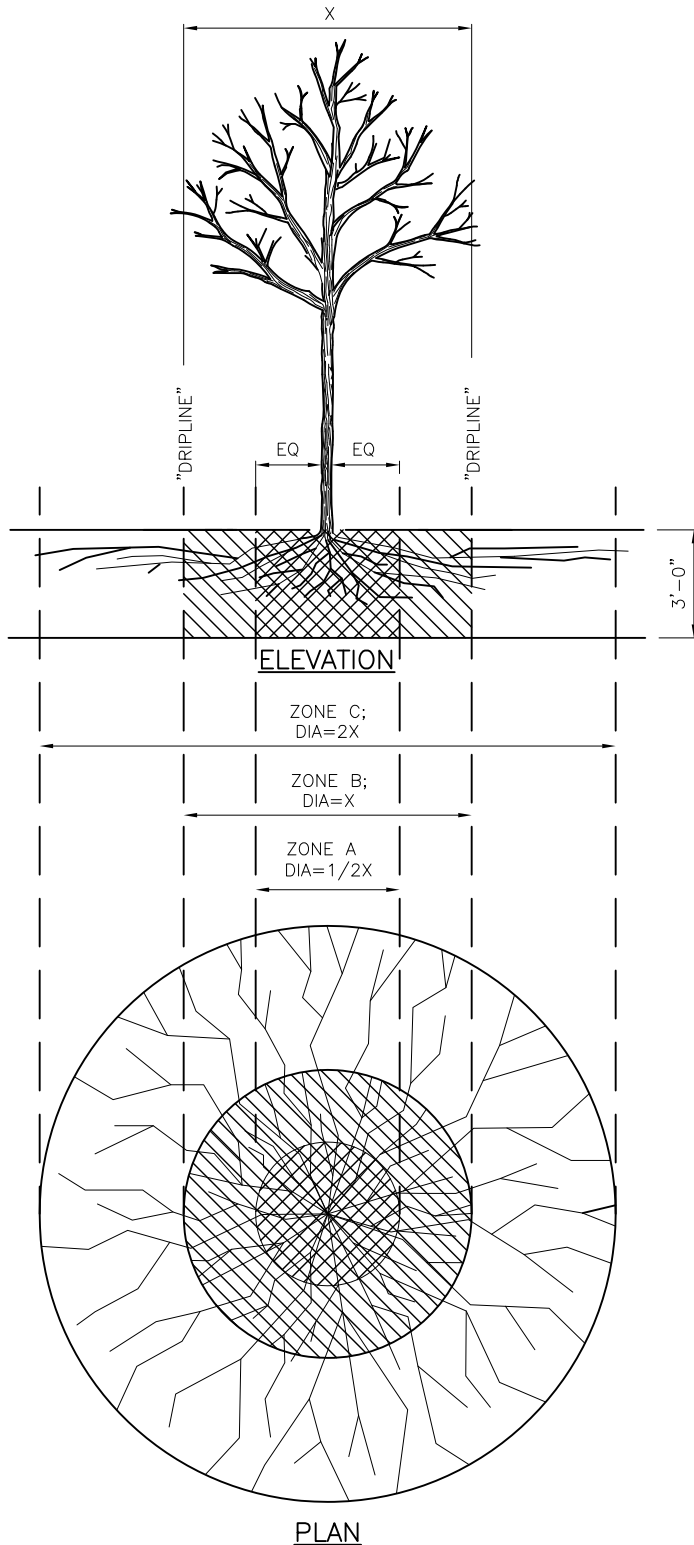

TRENCHING/EXCAVATION

ZONE A (CRITICAL ROOT ZONE)

1. NO DISTURBANCE ALLOWED WITHOUT SITE-SPECIFIC INSPECTION AND APPROVAL OF METHODS TO MINIMIZE ROOT DAMAGE
2. SEVERANCE OF ROOTS LARGER THAN 2" DIA REQUIRES ENGINEER'S APPROVAL
3. TUNNELING REQUIRED TO INSTALL LINES 3'-0" BELOW GRADE OR DEEPER

ZONE B (DRIPLINE)

1. ZONE B FOR ASYMMETRICAL COLUMNAR AND NARROW CONICAL TREE FORMS. ZONE B = 1' RADIUS FOR EVERY 1" OF TRUNK DIAMETER.
2. TUNNELING MAY BE REQUIRED FOR TRENCHES DEEPER THAN 3'-0".

NOTE:

A TREE, VEGETATION, AND SOIL PROTECTION PLAN (TVSPP) IS REQUIRED FOR ALL PROJECTS. APPROVAL OF PLAN REQUIRED PRIOR TO MOBILIZATION. SEE SECTION 8-01.

REF STD SPEC SEC 1-07.16(2) & 8-01



City of Seattle

NOT TO SCALE

**TREE PROTECTION DURING
TRENCHING, TUNNELING OR
EXCAVATION**

ZONE B is the dripline of the tree.

Typical trees: The dripline is identified as the area directly below the upper canopy of the tree

Columnar trees: The dripline radius equals one foot for every inch of trunk diameter measured at 54 inches above grade

Construction activities within the dripline may be performed without direct supervision of SDOT Urban Forestry if the following conditions are met:

- A plan is submitted that explains which Best Management Practices (BMPs) will be used to protect the tree, and where on the project they will be implemented.
and
- BMPs are included in the permit requirements and are in place as per the plan drawings.
or
- Less than 30 percent of the dripline area is impacted by the construction activities and roots two inches or greater in diameter are not affected.

The unpaved portion of the critical root zone must be fenced in all circumstances. If more than 30 percent of the dripline area is impacted by construction activities, a site review by SDOT Urban Forestry is required. All areas to be impacted by construction activities must be shown on the plan and reviewed prior to construction.

'PROTECT TREE' POSTING

A 'Protect Tree' sign shall be prominently displayed on each tree or tree protection fence within the work zone. An SDOT Urban Forestry representative shall provide the sign. No tree work can occur in trees that are posted with 'Protect Tree' signage. Urban Forestry must be contacted for the approval of necessary tree work. (See SDOT Client Assistance Memo 2307)

TREE PROTECTION FENCING

Fenced enclosures define protection limits to meet three primary requirements to:

- (1) protect tree canopy from damage by equipment, materials, and activities;
- (2) preserve roots and soil conditions in the CRZ and;
- (3) inform others –both the public and other contractors—that the area is not open for access.

Tree fencing must be put in place before structure demolition, grading or construction begins and remain in place until final inspection of the project permit, unless otherwise approved by SDOT.

For trees in open planting strips, all unpaved areas within the dripline of the tree shall be enclosed with the required chain link fencing or other methods approved by SDOT Urban Forestry, with the sidewalk and street open for public use. Standard Plan 132a is included here as a reference. For short duration projects of less than 48 hours involving street trees in paved, improved areas an alternative temporary fencing solution is acceptable. Standard Plan 132b is included in *Appendix E*, which details this alternative, temporary fencing.



NOTE:

CONSIDER TRAFFIC TURNING VISIBILITY AND PEDESTRIAN VISIBILITY WHEN SELECTING FENCE HEIGHT; TYPICALLY SHORTER FENCING AROUND TREE PITS BETWEEN SIDEWALK AND ROADWAY IS DESIRED.

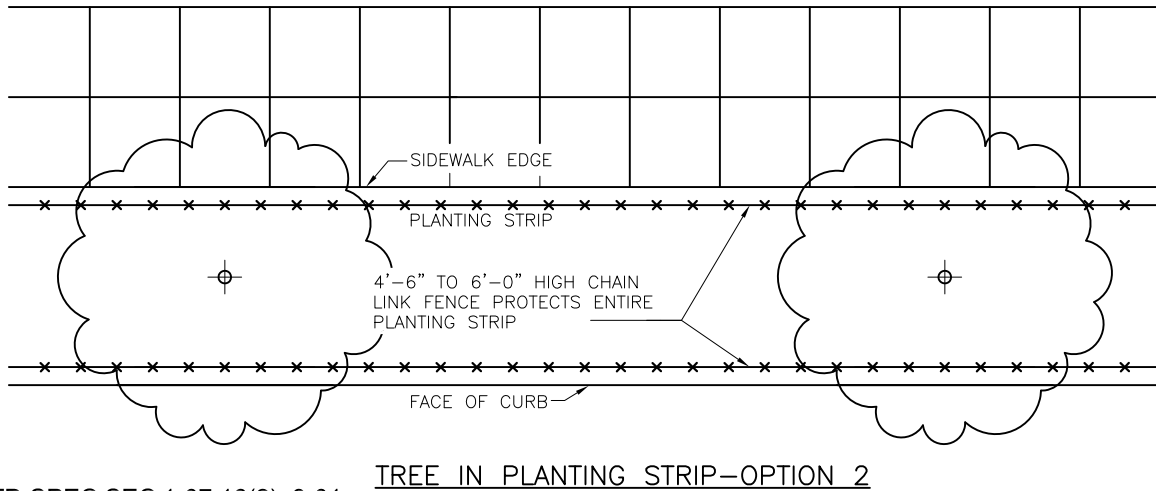
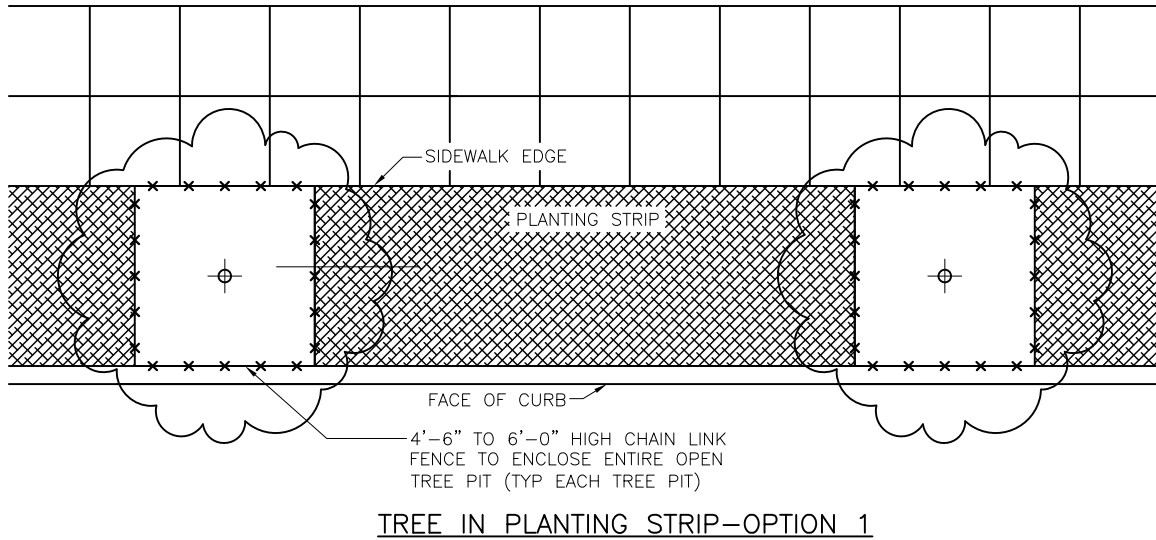
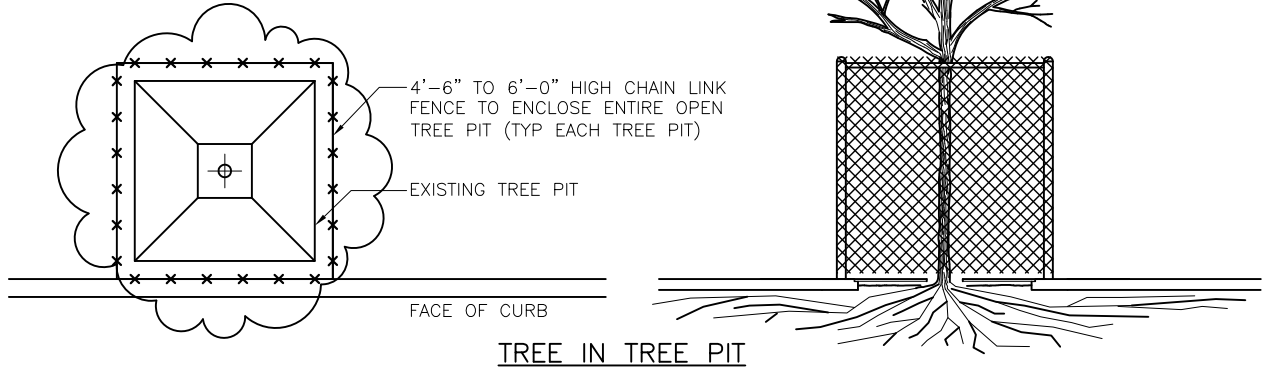

REF STD SPEC SEC 1-07.16(2), 8-01



City of Seattle

NOT TO SCALE

TREE PROTECTION
DURING CONSTRUCTION

REMOVAL AND REPLACEMENT OF PAVEMENT OR SIDEWALK

Removal of existing pavement over tree roots is often necessary within the critical root zone and the dripline. Tree protection measures submitted as part of the permit application shall describe the strategies to be employed in the work zone. In all cases, roots shall be protected from unnecessary injury. This is accomplished through careful execution of pavement break-out.

Once pavement is broken into manageable pieces, it can be carefully removed. Equipment must remain on undisturbed pavement and off exposed roots. Do not remove base rock or materials that have been exploited by established absorbing roots unless necessary to identify root pruning strategies. In dry and hot conditions, apply untreated wood chips, burlap or other approved means of moisture control over the exposed roots within one hour, and keep the area moist until overlay surface is applied.

ROOT PRUNING

SDOT Urban Forestry must approve removal/pruning of roots greater than two inches in diameter within the dripline of a street tree. All root pruning within the critical root zone must be overseen or directed by SDOT Urban Forestry.

PROMOTE LONGEVITY OF TREES AND PAVEMENT

Conflicts between trees and surrounding pavement and the associated costs can be avoided or reduced by the following planting practices:

- Follow soil loosening planting techniques to promote deep rooting.
- Find ways to maximize the available soil volume available for healthy root development. Keep as much soil volume un-compacted during pavement construction as possible.
- Install root barrier only along the hardscape side of a newly planted tree at the time of installation, allow roots to use open lawn or planter strip areas.

REPORTING INJURY TO TREES

Any damage or injury to trees must be reported within six hours to the job superintendent or project arborist, and SDOT Urban Forestry, with photographic

documentation, to ensure timely application of mitigation measures. All mechanical or chemical injury to branches, trunk, or roots over two inches in diameter must be reported.

PENALTIES FOR INJURING STREET TREES

In the event that street trees or their roots have been damaged in a manner that reduces tree health, vigor, or longevity but does not necessitate removal, penalties may be assessed as outlined in the section *Prohibited Acts and Penalties* of this manual. The civil penalty may be assessed as a percentage of the appraised value of the tree as calculated by the current edition of the Council of Tree and Landscape Appraisers 'Guide for Plant Appraisal'. If more than 50 percent of the roots, limbs, or circumference of trunk is damaged or destroyed, the tree will be considered a total loss. See the section on *Prohibited Acts and Penalties*.

COMMON CONSTRUCTION ACTIVITIES THAT ARE HARMFUL TO TREES

Below are common construction activities that generally require permitting and have the potential to harm or damage the tree's canopy, roots, and associated soils. If a project plans to perform any of these activities within dripline of a street tree, the applicant must notify SDOT as part of the permit application. The list below is not a comprehensive listing; the BMPs described on the permit will provide the additional specific practices necessary for the duration of the project. In addition to the list of construction activities, a set of prevention and remediation strategies are also provided.

GRADING

Grading activities involve soil disturbance that may damage the soil structure and the biological environment for tree roots and other vegetation elements.

Any grade changes within the dripline require site-specific mitigation and remediation. Both the removal and addition of soil in within the dripline of a street tree can have long-term detrimental effects on tree health.

TRENCHING, EXCAVATION, TUNNELING AND DIRECTIONAL DRILLING

Below-grade activities may impact soils, tree roots and the biological systems that support trees and vegetation. Any trenching, excavation, or directional drilling activity within the Critical Root Zone is restricted.

Preventative and remedial steps to follow for below-grade activities:

- Do not allow construction activities within the dripline of trees.
- Excavation, trenching or tunneling for drainage, utilities, irrigation lines, etc., may necessitate tunneling under roots. For excavation necessitating the pruning of tree roots two inches or larger, pruning must be approved prior to execution of the work and, if allowed, subject to industry standards for clean cuts back to a lateral root and sound wood.
- Allowable effective methods include hand digging, air or water excavation technology. Water excavation has a high potential for root damage if nozzle is used too close to root surfaces.
- Tree protection measures to minimize exposure of roots to dry conditions are commonly required unless backfill of excavation is scheduled within the same workday.
- Root protection measures include backfilling or covering exposed root areas within 1 hour. Exposed roots may be kept from drying out by temporarily covering the roots and draping layered burlap or carpeting over the upper three feet of trench walls. The materials must be kept wet until the trench is backfilled to reduce evaporation from the trench walls.
- Pruning of roots outside of the Critical Root Zone and smaller than two inches diameter exposed by excavation must be cut to sound wood and repaired. Roots two inches in diameter and greater must remain injury free.

HEAVY EQUIPMENT USE

Construction activities that include heavy equipment have the potential to damage soil and tree roots by compaction of the air spaces within the soil. If compaction of the soil occurs, it must be mitigated as directed by SDOT Urban Forestry for optimum

compatibility with the tree species, soil, and site conditions.

The use of backhoes, steel tread tractors or any heavy vehicles within the Critical Root Zone is prohibited without protection measures approved by SDOT Urban Forestry. If equipment use is allowed, a protective root buffer is required.

Preventative and remedial steps to follow for heavy equipment use in the Critical Root Zone:

- Protective buffer of arborists' chips or hog fuel spread over the root area to a minimum of six inch depth to protect surface roots or place two to three inches of wood chip mulch and lay a one inch steel plate or ¼ inch thick plywood. This buffer within the critical root zone must be maintained throughout the entire construction process.
- Use soil and tree surface protection to reduce the impacts from compaction and/or soil erosion. Maintain moist mulch cover as a root buffer and temporary erosion and sediment control measure for exposed soil. Spray wash trunk, limbs, and foliage to remove accumulated construction dust.

Soil Reconditioning/remedial measures may include:

- **Aeration:** Soil that is damaged or compacted within the dripline of street trees shall be loosened or aerated to promote root growth and enhance tree vitality. One of the following aeration methods shall be specified in an effort to correct compacted soil conditions.
- **Radial Trenching:** With an air excavator, excavate a soil trench three to six inches wide and a minimum of 12 inches deep from approximately three feet from the trunk out to the dripline area. The trenches shall radiate out from one foot apart at the closest point.
- **Vertical Mulching:** Auger holes two to four inch diameter, two to three feet deep, on four foot centers and backfilled with porous material such as perlite, vermiculite or volcanic rock.
- **Soil-fracturing:** With an air spade or knife. Subsurface injections under moderate hydraulic pressure using a three foot probe and applied on three foot centers under the dripline.

PRIVATE DEVELOPMENT AND MAJOR UTILITY PROJECTS

DPD Master Use Permits (MUP)/SDOT SIPs/Major Utility Projects

Development projects permitted by DPD and/or SDOT (both public and private) and Utility Major Projects are subject to design review and specific permit conditions related to street trees that meet or exceed minimum requirements established in Standard Specifications, the Right-of-Way Improvements Manual, and this manual.

City of Seattle Standard Specifications 1-07.16(2) and 8-01.3(2)B require the submittal of a Tree, Vegetation, and Soil Protection Plan (TVSPP) subject to field review prior to approval of the submittal necessary for mobilization prior to construction. Project applicants are responsible for compliance with these requirements and are encouraged to provide this TVSPP with a minimum of 5 business days' notice to the SDOT Street Use and Urban Forestry Inspector and SDOT Urban Forestry Landscape Architect's Office to schedule the required field review.

- Tree protection measures, once confirmed by field review, shall be documented in the final TVSPP submittal prior to approval
- Tree protection measures shall be maintained by the project for the duration of construction activity as directed by the project engineer.

Any damage or injury to trees must be reported within six hours to the job superintendent or project arborist, and SDOT Urban Forestry, with photographic documentation, to ensure timely application of mitigation measures and/or avoid monetary assessment for loss of tree value. All mechanical or chemical injury to branches, trunk, or roots over two inches in diameter must be reported.

TREE REPLACEMENT FOR DEVELOPMENT PROJECTS

Authorization for removal of street trees as a part of a private development project commonly includes conditions for mitigation by the project permittee. Authorization for removal of street trees for development projects is administered by the SDOT Urban Forestry Landscape Architect's office as a component of the DPD MUP or SDOT Street Improvement Permit (SIP) process. Tree value is determined by using The 'Guide for Plant Appraisal' published by the Council of Tree and Landscape Appraisers, current edition.



HERITAGE TREE PROGRAM

The Heritage Tree Program was initiated by PlantAmnesty in partnership with the City of Seattle in 1996. The first Heritage Tree was recognized jointly by the City of Seattle and PlantAmnesty in 1996.

Heritage Trees may be street trees, private property trees, or belong to another City Department such as Department of Finance and Administrative Services or Department of Parks and Recreation. Any interested person may nominate trees, then each tree is assessed by a certified arborist and evaluated by a review committee. Trees can be nominated as an individual or a collection, but must have the owner's approval and meet criteria for health in addition to being selected according to one of the following categories:

Specimen: A tree of exceptional size, form, or rarity.

Historic: A tree recognized by virtue of its age, its association with or contribution to a historic structure or district, or its association with a noted person or historic event.

Landmark: Trees that are landmarks of a community.

Collection: Trees in a notable grove, avenue, or other planting.

Each Heritage Tree may be identified by a plaque and the owners are given an owner's tree care manual. A few owners have chosen to place a deed restriction on their property to provide for future tree protection.



All are regulated trees. Those growing in street rights-of-way are regulated by virtue of being street trees, and require a permit to perform any work on them. Those growing on private property are afforded exceptional tree status by the Department of Planning and Development.

ADDITIONAL RESOURCES

To learn more about the benefits of trees and their proper care and maintenance, visit these websites:

ONLINE RESOURCES

Seattle City Light's "The Right Tree Book": for selecting, planting and pruning the Right tree.

www.seattle.gov/light/printdocs/right_tree_book.pdf

Seattle reLeaf: the one-stop-shop for all things tree related in the City of Seattle.

www.seattle.gov/trees/

Trees Are Good: the International Society of Arboriculture's tree care site.

www.treesaregood.com/

National Arbor Day Foundation: the Right Tree in the Right Place homepage.

www.arborday.org/trees/righttreeandplace/

GLOSSARY OF TERMS

Certified Arborist: An individual who is current with the International Society of Arboriculture (ISA) requirements and qualifications to be rated as a Certified Arborist.

Certified Tree Worker: An individual who is current with the International Society of Arboriculture (ISA) requirements and qualifications to be rated as a Certified Tree Worker.

Critical Root Zone (Zone A): Area of tree protection, the radius of which is half of the dripline. Critical Root Zone is often referred to as the CRZ, and is calculated as six inches of radius for every inch of trunk diameter measured at 54 inches above grade.

Director: When this term appears within this document, it refers to the Seattle Department of Transportation (SDOT) Director.

Disturbance: Any action with the potential to impact a tree including but not limited to change in soil or drainage conditions in area supporting roots. (See Standard Specification for TVSPP 8-02)

Dripline (Zone B): For typical trees, this is the area directly below the upper canopy of the tree. In the case of columnar trees, or to calculate this area: the dripline radius equals 1 foot for every inch of trunk diameter measured at 54 inches above grade. Construction activities within the dripline are restricted.

Excessive Pruning: Removing more than ¼ (25 percent) of the functioning leaf, stem or root area. Pruning in excess of 25 percent may be injurious to the tree and is a prohibited act. Excessive pruning (including pruning and removal of roots; removal of the leaf or stem area predominantly on 1 side;

topping; or excessive tree canopy or crown raising) deemed necessary to meet mandated standards for public safety may be permitted as an exception, with conditions to ensure tree health. SDOT Urban Forestry will make the determination based on tree species, age, and/or site conditions.

Girdling: A selective wounding process that removes bark and underlying cambial tissue from the trunk or scaffold branches. In the case of roots, the term refers to roots that grow around the main stem and cut off or restrict the movement of water, nutrients, and food reserves.

Hazardous Tree: Refers to any tree or tree part that poses a high risk of damage to persons or property located in the public place, as determined by the Director according to the tree risk evaluation standards established by the International Society of Arboriculture (ISA).

Heritage Tree: A tree or group of trees, given special designation by the Heritage Tree Program, co-sponsored by Plant Amnesty and the Seattle Department of Transportation. Heritage tree classifications shall be maintained in the Street Tree Manual.

Injury: The term injury refers to a tree wound resulting from any activity, including but not limited to excessive pruning, improper pruning cuts, cutting, girdling, trenching, excavating, grade alteration, paving, or compaction within the tree protection zone of a tree. Injury shall include bruising, scarring, tearing or breaking of roots, bark, trunk, branches or foliage, herbicide or poisoning, or other action predictably leading to the death or permanent damage to tree health (SMC 15.43.020).



Planting Strip: The term planting strip means that part of a street right-of-way between the abutting property line and the curb or traveled portion of the street, exclusive of any sidewalk (SMC 10.52.010H).

Pruning, Major: Major pruning means removal of branches two inches in diameter or greater; removal of roots two inches in diameter or greater; or removal of branches constituting more than 15 percent of a tree's foliage bearing area.

Public Places: The public right of way and the space above or beneath its surface, whether or not open or improved, including streets, avenues, ways, boulevards, drives, places, alleys, sidewalks, planting strips, squares, triangles, and plazas that are not privately owned. The Street Tree Ordinance and this

manual do not regulate trees and vegetation located on city property or public places under the jurisdiction of the Seattle Parks and Recreation Department or the Department of Finance and Administrative Services.

Recommended Practice: An action, treatment, technique, or procedure recommended for optimum tree health and growth to maturity. Recommended practices may be required under specific conditions of approval for development projects or injury mitigation. Each recommended practice is highlighted within the manual by a green shaded area.

Root Buffer: A temporary layer of material to protect the soil texture and roots. Buffer requirements are defined by SDOT Urban Forestry based on a field inspection of the tree, site and related conditions.

Severe Crown Reduction: The reduction of the overall size of the tree by altering the tree's natural structure, cutting limbs back to lateral limbs less than one-third of the diameter of the limb that is cut.

SDOT: Seattle Department of Transportation

Street Tree: Refers to any tree planted or growing within public places.

Structural Defect: Condition within a tree due to natural deformity, damage, or mismanagement deemed by a tree risk assessments indicative of a structural weakness.

Target: A term used to include the presence of people, vehicles, structures, or property subject to damage by a tree that cannot be moved to mitigate risk.

Topping: The severe and indiscriminate cutting back of limbs to stubs within the tree's crown, to such a degree as to remove the normal canopy and disfigure the tree; or the cutting back of limbs or branches to lateral branches that are not sufficiently large enough to assume the terminal role, or are less than one-half of the diameter of the limb or branch that is cut.

Tree Canopy: The area of the city covered by the branch and leaf structure of trees. In the case of an individual tree, canopy is the branches and leaves.

Tree Protection Fencing: A temporary enclosure erected around a tree to be protected; subject to field approval by SDOT Urban Forestry. As a tree protection measure fencing provides protection of unpaved areas within the Tree Protection Zone; as well as identification of the tree for protection from construction impacts to trunk and canopy (see City of Seattle Standard Plans and Specifications for Municipal Construction: Specifications 1-07.16(2), 8-01.3(2) A and B; Plans 132 a, 132 b, & 133)

Tree Risk Assessor (Qualified): Individual who has completed all requirements of the ISA Tree Risk Assessment Qualification (TRAQ) course.

Tree Service Provider: Individual or business entity that engages in the business of pruning, removing, or otherwise treating trees for monetary or other compensation.

Tree, Vegetation, and Soil Protection and Preservation Plan: A comprehensive plan depicting tree, vegetation and soil protection measures necessary as a condition of the current "City of Seattle Stormwater Code," for projects permitted by the City of Seattle. Tree protection is reviewed and approved by SDOT Urban Forestry. Plan requirements typically include measures for preconstruction, demolition, and/or construction to confirm the natural dripline and establish a critical root zone (CRZ) for each tree. Plan components may include a tree monitoring and inspection schedule and conditions for continued maintenance of trees after construction according to the requirements in this manual.

Trenching: Any excavation to install or repair foundations, utility lines, services, pipe, drainage, irrigation infrastructure or other property improvements below grade. Trenching within the CRZ is injurious to roots and tree health and is prohibited, unless approved. If trenching is approved within the CRZ, it must be in accordance with instructions outlined in this manual.

APPENDIX A:

Guidance for Tree Service Selection

GUIDANCE FOR SELECTION OF A TREE SERVICE PROVIDER

Hiring a tree service provider deserves careful consideration and caution. A mistake can be long-lasting and expensive, while the right choice can assure health, beauty and longer life for your trees and landscape. The following suggestions are provided to help you select an arborist.

1. Determine whether the tree service provider is affiliated with a professional organization such as the International Society of Arboriculture (ISA). Membership does not guarantee quality, but a lack of it may cast doubt on the company's commitment to professionalism.

The ISA provides additional information regarding selection of a tree service provider. For example, the ISA advises homeowners to be wary of individuals who go door-to-door offering bargains for tree work. Most reputable companies are too busy to solicit work in this manner.

See: www.treesaregood.com/treeowner/whyhireanarborist.aspx

2. Ask for local references and other jobs the company has done in Seattle. Experience, education, and good reputation are signs of a good tree service provider and arborist.
3. Have more than one arborist look at your job and give you a written estimate that clearly states their scope of work. Don't expect a company to lower its bid to match another's bid. Be willing to pay for the estimate if necessary. Two or more opinions and estimates are worth the extra effort.

4. To be assured of having your work performed to the standards you expect, a contract should be obtained that includes the following basics:
 - Dates that work will begin and end.
 - Follow the pruning plan supplied with the permit. If your tree is to be sprayed, get a written statement detailing the insect or disease to be treated, the chemical to be used and what precautions you need to take (cover patio furniture, keep pets inside, etc.). If fertilizer, how many pounds of fertilizer per inch of trunk diameter will be applied and by what method?
 - Cleanup procedures should be listed and whether firewood will need to be cut (and into what lengths) should both be mentioned.
 - Clarify if a tree removal includes grinding the stump and surface roots and if so, how deep?
 - Will they remove grindings and backfill the hole?
 - The total dollar amount you will be charged.

Typically, Work is priced in one of two ways: (a) as a single price for the job, or (b) on an hourly basis plus materials. When using the latter, be sure to include the wording, "...but not to exceed..."

5. Require a certificate of insurance, including liability for personal injury and property damage (such as your house and your neighbor's), and workers compensation. Phone their insurance company to make certain each policy is current. Under some circumstances, the property owner may be held financially responsible if an uninsured worker is hurt on your property, or if damage is done to a neighbor's property.

SDOT URBAN FORESTRY PERMITTING REQUIREMENTS

Only tree service providers who are registered with SDOT Urban Forestry are allowed to perform work on street trees in Seattle. The business requirements for these service providers include:

- State of Washington General Contractor's License
- City of Seattle Business License
- Show proof of commercial general liability insurance that names the City of Seattle as an additional insured for primary limits of liability, with a minimum of \$1,000,000 in coverage.
- ISA Certified Arborist or Certified Treeworker credentials

SDOT Urban Forestry requires registered Tree Service Providers to have read and understand the Street Tree Ordinance (SMC 15.43), Street Tree Manual, ANSI –A-300, Pruning Standards, and the City of Seattle Traffic Control Manual.

To determine whether the tree service provider is registered with SDOT Urban Forestry, go to the webpage link: www.seattle.gov/transportation/treecompanypermits.htm

USING ARBORISTS FOR PREVENTATIVE CARE

A proactive tree and plant health care program can assure that minor, early pruning will prevent major, corrective pruning later on. An annual inspection will likely help you sustain the property value appropriate for the investment made in trees and related landscape improvements.

Consulting arborists also offer advice and appraisals, diagnosis of problems and recommend treatment. They also can serve as a 'second opinion', if needed. The American Society of Consulting Arborists maintains a registry of current members and registered Consulting Arborists.

Visit: www.asca-consultants.org

APPENDIX B:

Street Tree Watering Recommendations

WATERING RECOMMENDATIONS

Newly planted trees, including drought tolerant species, are dependent upon supplemental irrigation until established, typically for two to three years. Periods of extreme heat, wind or drought may require more or less water than recommended here. The method and amount that is applied may vary depending upon soil composition, heat, wind, planted in turf or ground cover, periods of abnormal rainfall or in poorly drained soils. The watering of street trees should follow these guidelines:

Frequency:

- New trees
 - During the establishment period (1-3 years) trees should be watered thoroughly to their root depth as frequently as needed. With each watering, the recommended amounts are 5 gallons per caliper inch.

The minimum standards should be as follows:

- 1-3 months in the ground: 4 times per month or as necessary
- 4-6 months in the ground: 3 times per month or as necessary
- 7-12 months in the ground: 2 times per month or as necessary

- Mature, well-established trees
 - Once per month during irrigation/dry season (usually July through September)

WATERING METHODS

The following options shall fulfill the watering requirements. One or more of the following may be utilized dependent upon unique circumstances

subject to SDOT Urban Forestry's determination. The options are as follows:

Automated Watering System. These systems should be designed and installed by qualified, trained irrigation technicians. A water audit should be performed to set watering patterns and timing to minimize waste.

Drip Loop system. A continuous loop of drip tubing circling around the trunk at a point two-thirds out from the trunk to the edge of the root ball (for new trees 36-inch box size and greater, a second loop of drip tubing is required at a point just beyond the rootball on native soil).

Hand watering systems. Recommended for trees that are part of a development project that must be watered to insure tree survival during the course of construction until automatic irrigation is installed.

Flood watering. Newly installed trees must be 'flood or basin-watered' on top of the root ball to allow the water to infiltrate through the root zone. Subsurface injections using a hydraulic spray pump may be used (practical for use in hard, compacted soils or steep hillsides).

Soaker hose. Slow, deep watering using a garden-type soaker hose.

AMOUNT

Unless otherwise specified, the volume of water applied at each irrigation site should be in the range of 5-gallons per inch of trunk diameter when measured at 54-inches above natural grade. The final decision of whether to water or not should be based on accurate soil probe samples that are taken from the root ball.

APPENDIX C:

Insects and Disease Control

Generally, insect populations do not threaten tree health to the point of mortality. More often, when their populations become too great they create a nuisance. For example, aphids feeding on linden, birch, oak or maple, produce sticky honeydew that may be a nuisance if dripping on cars or at a storefront entry. If action is warranted, Integrated Pest Management (I.P.M.) suggests that the pest source be identified and targeted with a specific and timely treatment. If insects or disease can lead to the death of a street tree, it is the responsibility of the property owner to evaluate the condition according to the following guidelines and treat the problem in a timely fashion to prevent further deterioration of the tree.

INSECTS

For treatment, consult a WSDA licensed applicator who is licensed for the control of the target pest. Accurate timing is critical for success. Nontoxic materials should be used whenever possible to control leaf-chewing insects.

DISEASE AND DECAY - ABOVE GROUND

Disease such as heart-rot decay that erodes the health or weakens the structure of a street tree may compromise the safety of people or property. It is the property owner's responsibility to correct a known hazardous condition in a timely fashion.

Consult with a certified arborist for possible treatment options. For example, pruning infected branches, thinning, or other chemical abatement options.

DISEASE - BELOW GROUND

Soilborne diseases, such as Oak Root Fungus (*Armillaria mellea*) or Root Rot (*Phytophthora sp.*), are present in Seattle soils. Often, a poor landscape design surrounding old trees encourages harmful and often lethal diseases. The following conditions that favor a disease environment must be avoided.

Conditions to avoid: Compacting of the soil within the tree's dripline, adding fill dirt, rototilling, trenching, removing soil from the tree root area, and excessive or regular watering on or near the tree trunk area and planting incompatible water-loving plants within the tree's dripline. Combined with poorly-drained soil, these factors often activate normally dormant fungi to become opportunistic and infect the tree to cause the decline and eventual death of the tree. This decline can be slow and may not be evident for many years.

Landscape Design: When planning landscaping around a street tree, an evaluation of the tree and soil is an important first step to determine if there is a disease present. If the tree is diseased and landscaping will contribute to decline or permanent damage, it is the obligation of the property owner to take reasonable measures to reduce or eliminate the conditions that may cause the decline of the street tree. Setback for planting and/or irrigation beyond the critical root zone is often the most prudent option to sustain the health of a mature tree.

To identify cultural conditions that may lead to diseases such as Oak Root Fungus, Verticillium, Phytophthora or other soilborne fungi, review the *Sunset Western Garden Book* or consult with a Certified Arborist or Qualified Tree Care Professional. Plants selected for use under an oak should not need water more than once a month. Use a drip system to irrigate around an oak so that runoff does not flood the area.

FOLIAR (LEAF) DISEASE

Leaf spot or galls may be chronic or reoccur with specific seasons. Though many of these diseases destroy leaf tissue and become unsightly, they may not significantly reduce the trees health and therefore need not be treated.

APPENDIX D:
**Basic Tree Risk Assessment Guide/
Basic Tree Risk Assessment Form**

Using the ISA Basic Tree Risk Assessment Form

This form is provided with the *ISA Tree Risk Assessment Manual* and is intended to act as a guide for collecting and recording tree risk assessment information. This form is for trees receiving a basic (Level 2) risk assessment. It is *not intended for use* with limited visual (Level 1) or advanced (Level 3) assessments. Space is provided to write comments and notes for various conditions that are not included elsewhere on the form or for points that need additional explanation. *It is not necessary to mark every box or to fill in every line on this form.* Only information relevant to the tree risk assessment should be collected. You may adapt this form for your specific needs.

PAGE I—DATA COLLECTION

Section I—Assignment and Tree ID

Client _____	Date _____	Time _____	
Address/Tree location _____	Tree no. _____	Sheet _____ of _____	
Tree species _____	dbh _____	Height _____	Crown spread dia. _____
Assessor(s) _____	Time frame _____	Tools used _____	

This section outlines the basic information for you assessment. This will be valuable information when drafting your written report. Be sure to refer back to the time frame stated in this section when determining likelihood of failure later on this form.

Client—name of the person who hired you to perform the assessment or agency for which you are working.

Date—date of the tree inspection.

Time—time of the tree inspection.

Address/Tree location—the physical address, GPS coordinates, or other location description of the tree and the location of the tree on the property, such as “backyard” or “between street and sidewalk on the north side of walk.” A typical entry may be “411 Pine Street, Oakville. Large tree on left near driveway.”

Tree no.—if the tree has an inventory tag with a number, it should be entered here. If a group of trees without tags are assessed, they may be assigned a sequence number.

Sheet—if multiple sheets are used for a tree assessment—or if a group of trees are assessed—the sheet number and total number of sheets used on the job may be entered.

Tree species—include the common and/or scientific name of the tree; cultivar, if known.

dbh—diameter at breast height [U.S., 4.5 feet (1.37 m); or customary diameter measure for your country; IUFRO standard is 1.3 m above ground] measured in inches or cm.

Height—tree height either visually estimated or measured. If measured, the tool used for this measurement should be noted in Tools used.

Crown spread dia.—the average diameter of the drip line of the tree; measured or estimated.

Assessor(s)—name of the person or people collecting the tree risk information; may also include qualifications such as “TRAQ.”

Time frame—period in which you are estimating the likelihood of failure; typically between one and five years; Time frame should be considered when rating the likelihood of failure with all categories except imminent, which has a different time frame (very soon).

Tools used—list of tools used in the assessment such as “mallet” or “binoculars.” If no tools were used, write “none” or leave blank.

Section 2—Target Assessment

Target Assessment							
Target number	Target description	Target zone			Occupancy rate 1 – rare 2 – occasional 3 – frequent 4 – constant	Practical to move target?	Restriction practical?
		Target within drip line	Target within 1 x Ht.	Target within 1.5 x Ht.			
1							
2							
3							
4							

The Target Assessment chart is used to list target(s)—people, property, or activities that could be injured, damaged, or disrupted by a tree failure—within the striking distance (target zone) of the tree part concerned. Four lines are provided; additional targets can be listed on a separate form. Target information will correspond with the Risk Categorization chart on the back of the form.

Target number—many trees have multiple targets within the target zone; the target number is provided to list individual targets and to facilitate inclusion of this number in the Risk Categorization chart so that the target description does not need to be rewritten.

Target description—brief description such as “people near tree” “house,” “play area,” or “high-traffic street.” Location of the target can be noted by checking one of the distance boxes to the right of the description.

Target zone—identify where the targets are in relation to the tree or tree part:

Within drip line—target is underneath the canopy of the tree.

Within 1 × Ht—target is within striking distance if the trunk or root system of the tree fails (1 times the height of the tree).

Within 1.5 × Ht—target is within striking distance if the trunk or root system of the tree fails and there are dead or brittle branches that could shatter and fly from the failed tree.

Occupancy rate—an estimated amount of time the target is within the target zone. Use corresponding numbered codes (1–4):

- 1. Rare**—targets are very uncommon in the target zone.
- 2. Occasional**—the target is present infrequently or irregularly.
- 3. Frequent**—the target is present for a large portion of the day or week.
- 4. Constant**—the target is present at all times or nearly all times.

Practical to move target?—check box if it is practical to move the target out of the target zone if mitigation is required.

Restriction practical?—check box if it is practical to restrict access to the target zone.

Section 3—Site Factors

Site Factors	
History of failures _____	Topography Flat <input type="checkbox"/> Slope <input type="checkbox"/> _____ % Aspect _____
Site changes None <input type="checkbox"/> Grade change <input type="checkbox"/> Site clearing <input type="checkbox"/> Changed soil hydrology <input type="checkbox"/> Root cuts <input type="checkbox"/> Describe _____	
Soil conditions Limited volume <input type="checkbox"/> Saturated <input type="checkbox"/> Shallow <input type="checkbox"/> Compacted <input type="checkbox"/> Pavement over roots <input type="checkbox"/> _____ % Describe _____	
Prevailing wind direction _____ Common weather Strong winds <input type="checkbox"/> Ice <input type="checkbox"/> Snow <input type="checkbox"/> Heavy rain <input type="checkbox"/> Describe _____	

Site factors may influence the likelihood of tree failure. This section provides a list of common site factors that should be considered. There may be other site factors that are critical on a given site, or which you should note even if they are not on this form. Any of these factors can be further described in the space provided or on additional paper. Other site factors affecting wind load should be noted. These may include the site elevation, surface roughness, and hilltop locations.

History of failures—note and describe evidence of previous whole-tree failures on the site, and estimate the time frame for how recently they occurred. Previous branch failures should be noted in the Crown and Branches box (located in the Tree Defects and Conditions Affecting the Likelihood of Failure section of the form).

Topography—check boxes for flat or sloping topography; an estimate of the slope percentage may be included.

Aspect—the compass direction that the slope is facing.

Site changes—factors affecting the root system of the tree or the change in exposure of the tree to wind; check all that apply:

None—no evidence of recent site changes.

Grade change—soil was added or removed from the site.

Site clearing—adjacent trees, which may have blocked the wind, have been removed or significantly reduced.

Changed soil hydrology—changes have been made that affect water flow in or out of the site.

Root cuts—the root system has been cut or otherwise significantly damaged. Additional information on root cuts will be included in the Roots and Root Collar box.

Soil conditions—factors that can affect the ability of the root system to mechanically support the tree, as well as the general health and vitality of the tree; check all that apply:

Limited volume—soil volume limited by rocks, water table, building foundations, size of a container, or other factors.

Saturated—soil saturated due to poor drainage, high water table, excess irrigation, or location in a low area. May be saturated now or have a history of inundation.

Shallow—rooting depth limited by one or more factors including high water table, rock ledges, compacted layers, or underground structures such as parking decks.

Compacted—soil is severely compacted, limiting the depth, spread, and distribution of the root system.

Pavement over roots—concrete, asphalt, pavers, or other materials restricting root growth or water movement into the root zone. If present, enter the percentage of the area within the drip line that is paved.

Prevailing wind direction—a typical, consistent, moderate-to-strong wind, usually from a single direction, which has affected tree crown and root system development.

Common weather—trees will adapt to a number of climatic conditions if they occur regularly; check all that apply.

Section 4—Tree Health and Species Profile

Tree Health and Species Profile							
Vigor Low <input type="checkbox"/>	Normal <input type="checkbox"/>	High <input type="checkbox"/>	Foliage None (seasonal) <input type="checkbox"/>	None (dead) <input type="checkbox"/>	Normal ____%	Chlorotic ____%	Necrotic ____%
Pests _____			Abiotic _____				
Species failure profile Branches <input type="checkbox"/>			Trunk <input type="checkbox"/>	Roots <input type="checkbox"/>	Describe _____		

This section provides the opportunity to note any species specific failure patterns that you suspect may influence likelihood of failure. Any species information you feel is important should be noted in this section. Any of these factors can be further described in the spaces provided or on additional paper.

Vigor—an assessment of overall tree health; classify as low, normal, or high:

Low—tree is weak, growing slowly, and/or under stress.

Normal—tree has average vigor for its species and the site conditions.

High—tree is growing well and appears to be free of significant health stress factors.

Foliage—size and color are indications of tree health; compare with a healthy specimen of the same species in the area. Lines and boxes in this section allow data collection of the percentage of each category, or simply a check mark for presence:

None (seasonal)—a deciduous tree that has dropped its leaves for the winter.

None (dead)—a tree that has dropped its leaves because it is dead.

Normal—foliage size and color are normal for the species in the area.

Chlorotic—yellowish-green to yellow.

Necrotic—dead foliage in part of or the entire crown.

Pests—insects and diseases that may significantly affect tree health or stability.

Abiotic—abiotic problems that may significantly affect tree health or stability.

Species failure profile—any known failure problems with the species in the branches, trunk, or roots.

Section 5—Load Factors

Load Factors	
Wind exposure Protected <input type="checkbox"/> Partial <input type="checkbox"/> Full <input type="checkbox"/> Wind funneling <input type="checkbox"/> _____	Relative crown size Small <input type="checkbox"/> Medium <input type="checkbox"/> Large <input type="checkbox"/>
Crown density Sparse <input type="checkbox"/> Normal <input type="checkbox"/> Dense <input type="checkbox"/> Interior branches Few <input type="checkbox"/> Normal <input type="checkbox"/> Dense <input type="checkbox"/>	Vines/Mistletoe/Moss <input type="checkbox"/> _____
Recent or planned change in load factors _____	

Generally, two types of load need to be considered when evaluating tree risk. Dynamic load is from wind as it impacts the tree, and static load is from gravity acting on the tree. These two loads can interact.

Wind exposure—factors that affect wind load on the tree; check all that apply:

Protected—trees or structures in the area significantly reduce wind velocity or the tree’s exposure to wind.

Partial—other trees, or buildings near the tree, moderately reduce the impact of wind on the tree.

Full—tree is fully exposed to wind.

Wind funneling—wind may be “funneled” or “tunneled” (by buildings, canyons, large stands of trees) toward the tree so that wind velocity experienced by the tree is increased.

Relative crown size—comparison of the tree’s crown size to the trunk diameter; classify as small, medium, or large.

Crown density—the relative wind transparency of the crown:

Sparse—crown allows a large degree of wind and light penetration; varies with species.

Normal—indicates moderate wind and light penetration.

Dense—crown does not allow much light or wind penetration.

Interior branches—increase wind resistance but dampen branch/tree movement:

Few—little wind resistance and damping.

Normal—moderate wind resistance and damping.

Dense—significant wind resistance and damping.

Vines/Mistletoe/Moss—check box if present at moderate to high levels that increase weight or wind resistance. Moss refers to Spanish or ball moss (epiphytes).

Recent or planned change in load factors—record any factors, recent or planned, that may significantly affect the load on any defects.

Section 6—Tree Defects and Conditions Affecting the Likelihood of Failure

— Crown and Branches —

Unbalanced crown <input type="checkbox"/> LCR _____ % Dead twigs/branches <input type="checkbox"/> _____ % overall Max. dia. _____ Broken/Hangers Number _____ Max. dia. _____ Over-extended branches <input type="checkbox"/> Pruning history Crown cleaned <input type="checkbox"/> Thinned <input type="checkbox"/> Raised <input type="checkbox"/> Reduced <input type="checkbox"/> Topped <input type="checkbox"/> Lion-tailed <input type="checkbox"/> Flush cuts <input type="checkbox"/> Other _____	Cracks <input type="checkbox"/> _____ Lightning damage <input type="checkbox"/> Codominant <input type="checkbox"/> _____ Included bark <input type="checkbox"/> Weak attachments <input type="checkbox"/> _____ Cavity/Nest hole _____ % circ. Previous branch failures <input type="checkbox"/> _____ Similar branches present <input type="checkbox"/> Dead/Missing bark <input type="checkbox"/> Cankers/Galls/Burls <input type="checkbox"/> Sapwood damage/decay <input type="checkbox"/> Conks <input type="checkbox"/> Heartwood decay <input type="checkbox"/> _____ Response growth _____
--	---

Main concern(s) _____

Load on defect N/A Minor Moderate Significant _____
Likelihood of failure Improbable Possible Probable Imminent _____

This section provides a systematic checklist for assessing the tree, dividing it into “Crown and Branches”, “Trunk”, and “Roots and Root Collar”. Check only factors that apply to the assessed tree. These factors may or may not contribute to your Main concern(s), Load on defect, or Likelihood of failure.

Crown and Branches

Unbalanced crown—check box if foliage is not uniformly distributed.

Live crown ratio (LCR)—the ratio of the height of the live crown to the height of the entire tree [LCR=(crown height/tree height) × 100].

Dead twigs/branches—small diameter, dead branches; check box if present and indicate percentage and maximum size(s) in diameter.

Broken/Hangers—broken or cut branches remaining in the crown; record the number and size (maximum diameter).

Over-extended branches—check box if there are branches that extend beyond the tree’s canopy or that are excessively long with poor taper.

Pruning history—check appropriate boxes if pruning is known and relevant:

Crown cleaned—pruning of dead, dying, diseased, and broken branches from the tree crown.

Thinned—selective removal of live branches to reduce crown density. Other pruning types include, but are not limited to, structural, pollarding, espalier, and vista, and may be included in your notes.

Raised—removal of lower branches to provide clearance.

Reduced—pruning to decrease tree height or spread by cutting to lateral branches.

Topped—inappropriate pruning technique used to reduce tree size; characterized by internodal cuts.

Lion-tailed—inappropriate pruning practice removing an excessive number of inner and/or lower lateral branches.

Flush cuts—pruning cuts through (or removal of) the branch collar, causing unnecessary injury to the trunk or parent branch.

Other—note any other pruning history that may affect the likelihood of failure.

Cracks—separation in the wood in either a longitudinal (radial, in the plane of ray cells) or transverse (across the stem) direction; check box if present and describe briefly.

Lightning damage—often evidenced by a centrally located line of sapwood damage and bark removal on either side in a spiral pattern on the trunk or branch; check box if present.

Codominant—branches of nearly equal diameter arising from a common junction and lacking a normal branch union. Check box if present and describe.

Included bark—bark that becomes embedded in a union between branch and trunk, or between codominant stems, causing a weak structure. Check box if present.

Weak attachments—branches that are codominant or that have included bark or splits at or below the junctions. Check box if present and describe.

Cavity/Nest hole—openings from the outside into the heartwood area of the tree; record the percentage of the branch circumference that has missing wood.

Previous branch failures—check box if there is evidence of previous branch failures and describe briefly. Note “similar branches present,” if relevant.

Dead/Missing bark—check box if branches are dead or if areas of dead cambium are present where new wood will not be produced.

Cankers/Galls/Burls—check box if relevant and circle which one(s) are of concern:

Canker—localized diseased areas on the branch; often sunken or discolored.

Gall—abnormal swellings of tissue caused by pests; may or may not be a defect.

Burl—outgrowth on the trunk, branch, or roots; not usually considered a defect.

Sapwood damage/decay—check box if there is mechanical or fungal damage in the sapwood that may weaken the branch, or decay of dead or dying branches. If checked, you may circle “damage” or “decay” to indicate which one is present.

Conks (mushrooms, brackets)—fungal fruiting structures; common, definite indicators of decay. Check box if present and describe under Main concern(s).

Heartwood decay—check box if present and describe.

Response growth—reaction wood or additional wood grown to increase the structural strength of the branch; note location and extent.

Main concern(s)—conditions in the crown and branches that may affect likelihood of failure. Note the main concern(s); if there are no concerns, write “none.”

Load on defect—a consideration of how much loading is expected on the tree part of concern. Record as N/A (not applicable), minor, moderate, or significant, and/or note the cause of loading.

Likelihood of failure—the rating (*improbable, possible, probable, or imminent*) for the crown and branches of greatest concern. If there is a main concern, this information should be transferred to the Risk Categorization chart.

— Trunk —

Dead/Missing bark Abnormal bark texture/color
 Codominant stems Included bark Cracks
 Sapwood damage/decay Cankers/Galls/Burls Sap ooze
 Lightning damage Heartwood decay Conks/Mushrooms
 Cavity/Nest hole _____ % circ. Depth _____ Poor taper
 Lean _____° Corrected? _____
 Response growth _____
 Main concern(s) _____

Load on defect N/A Minor Moderate Significant
Likelihood of failure
 Improbable Possible Probable Imminent

Trunk

Dead/Missing bark—check box if a stem or codominant stem is dead or if areas of dead cambium are present where new wood will not be produced.

Abnormal bark texture/color—may indicate a fungal or structural problem with the trunk; check box, if present, and add notes if it is a concern.

Codominant stems—stems of nearly equal diameter arising from a common junction and lacking a normal branch union. Note the size, location, and number, if relevant, under Main concern(s) in the Trunk box.

Included bark—bark that becomes embedded in a union between branch and trunk, or between codominant stems, causing a weak structure; check box if present.

Cracks—separation in the wood in either a longitudinal (radial, in the plane of ray cells) or transverse (across the stem) direction; check box if present and describe.

Sapwood damage/decay—check box if there is mechanical or fungal damage in the sapwood that may weaken the trunk. If checked, you may circle “damage” or “decay” to indicate which one is present.

Cankers/Galls/Burls—check box if relevant and circle which one(s); may or may not affect the structural strength of the tree:

Canker—localized diseased areas on the branch; often sunken or discolored.

Gall—abnormal swellings of tissue caused by pests; may or may not be a defect.

Burl—outgrowth on the trunk, branch, or roots; not usually considered a defect.

Sap ooze—oozing of liquid that may result from infections or infestations under the bark. May or may not affect structure or stability; check box if present.

Lightning damage—often evidenced by a centrally-located line of sapwood damage and bark removal on either side in a spiral pattern on the trunk or branch; check box if present.

Heartwood decay—Check box if present and identify/describe under Main concern(s).

Conks/Mushrooms (brackets)—fungal fruiting structures; common, definite indicators of decay when on the trunk; check box if present and identify/describe under Main concern(s).

Cavity/Nest hole—openings from the outside into the heartwood area of the tree; record the percentage of the trunk circumference that has missing wood, and the depth of the cavity.

Poor taper—change in diameter over the length of the trunk, important for even distribution of mechanical stress; check box if trunk has poor taper.

Lean—angle of the trunk measured from vertical; record the degree of lean.

Corrected?—the tree may have been able to “correct” the lean with new growth in the younger portions of the tree; note conditions related to lean in the space provided.

Response growth—reaction wood or additional wood grown to increase the structural strength of the trunk; note location and extent.

Main concern(s)—conditions in the trunk that may affect likelihood of failure. Note the main concern(s); if there are no concerns, write “none”.

Load on defect—a consideration of how much loading is expected on the tree part of concern. Record as N/A (not applicable), minor, moderate, or significant, and/or note the cause of loading.

Likelihood of failure—the rating (*improbable, possible, probable, or imminent*) for the trunk. If there is a main concern, this information should be transferred to the Risk Categorization chart.

— Roots and Root Collar —

Collar buried/Not visible Depth _____ Stem girdling

Dead Decay Conks/Mushrooms

Ooze Cavity _____% circ.

Cracks Cut/Damaged roots Distance from trunk _____

Root plate lifting Soil weakness

Response growth _____

Main concern(s) _____

Load on defect N/A Minor Moderate Significant

Likelihood of failure

Improbable Possible Probable Imminent

Roots and Root Collar

Collar buried/Not visible—check box if the root collar is not visible and, if possible, determine and note the depth below ground.

Stem girdling—restriction or destruction of the trunk or buttress roots; check box if it is a failure concern.

Dead—check box if one or more structural support roots are dead.

Decay—check box if present and identify/describe under Main concerns.

Conks/Mushrooms (brackets)—fungal fruiting structures; common, definite indicators of decay; fungal fruiting structures away from the trunk in the turf or mulch may be due to the presence of a mycorrhizal fungus and, if so, do not pose a threat to the tree. Check box if present and identify/describe under Main concern(s).

Ooze—seeping or exudation that can result from pest infestations or infections under the bark; check box if present and describe.

Cavity—definite indicators of heartwood decay; measure the size of the opening and record the percentage of the tree’s circumference affected.

Cracks—separation in the wood in either a longitudinal (radial, in the plane of ray cells) or transverse (across the stem) direction; check box if present and describe.

Cut/Damaged roots—check box if present; measure and record the distance from the trunk to the cut.

Root plate lifting—soil cracking or lifting indicates the tree has been rocking, usually in high winds; check box if present, and note under Main concern(s).

Soil weakness—check box if there is a soil condition affecting the anchorage of the tree’s root system; note under Main concern(s) if significant.

Response growth—reaction wood or additional wood grown to increase the structural strength of the roots or root collar; note location and extent.

Main concern(s)—conditions in the roots and root collar that may affect likelihood of failure. Note the main concern(s); if there are no concerns, write “none”.

Load on defect—a consideration of how much loading is expected on the tree part of concern. Record as N/A (not applicable), minor, moderate, or significant, and/or note the cause of loading.

Likelihood of failure—the rating (*improbable, possible, probable, or imminent*) for the roots or root collar. If there is a main concern, this information should be transferred to the Risk Categorization chart.

PAGE 2—RISK CATEGORIZATION AND MITIGATION

The second page of the form focuses on categorizing the risk the tree poses and describing how the risk should be mitigated. It also provides space for additional notes or comments regarding any section from the first page. Use a separate sheet of paper if more space is needed.

Section 7—Risk Categorization

Risk Categorization																							
Condition number	Tree part	Conditions of concern	Part size	Fall distance	Target number	Target protection	Likelihood												Consequences				Risk rating of part (from Matrix 2)
							Failure				Impact				Failure & Impact (from Matrix 1)				Negligible	Minor	Significant	Severe	
							Improbable	Possible	Probable	Imminent	Very low	Low	Medium	High	Unlikely	Somewhat	Likely	Very likely					
1																							
2																							
3																							
4																							

Matrix 1. Likelihood matrix.

Likelihood of Failure	Likelihood of Impacting Target			
	Very low	Low	Medium	High
Imminent	Unlikely	Somewhat likely	Likely	Very likely
Probable	Unlikely	Unlikely	Somewhat likely	Likely
Possible	Unlikely	Unlikely	Unlikely	Somewhat likely
Improbable	Unlikely	Unlikely	Unlikely	Unlikely

Matrix 2. Risk rating matrix.

Likelihood of Failure & Impact	Consequences of Failure			
	Negligible	Minor	Significant	Severe
Very likely	Low	Moderate	High	Extreme
Likely	Low	Moderate	High	High
Somewhat likely	Low	Low	Moderate	Moderate
Unlikely	Low	Low	Low	Low

This form uses the risk categorization methodologies presented in the ISA's *Best Management Practices: Tree Risk Assessment*. The chart provided on the form is a tool to tie the data collected on the front of the form to the risk categorization process. You can rate the risk for up to four different conditions that may be found in the tree being assessed. Additional ratings may be made on an additional form. If there is only one condition of concern, only one line needs to be completed.

Tree part—specify the branch, trunk, or root of concern. For example, Condition Number 1 may be the broken branch over the house, and Condition Number 2 may be a branch over the driveway. The entries in the Tree Part column would both be “branch.” Other options for this column include “trunk” and “roots.”

Conditions of concern—identify the concern(s) with the tree part listed. An example would be “large, dead branch over the house.”

Part size—a characterization of the part of the tree that may fail toward the target. Usually this is the diameter of the branch that can fall or the dbh of the tree. It may be appropriate to indicate the size of the part that could impact the target. Include units of measurement.

Fall distance—if applicable, record the distance that the tree or tree part will fall before hitting a target; this may be relevant to the consequences of failure.

Target number—this number should correspond to the target(s) listed on the first page of this form.

Target protection—note any significant factors that could protect the target because this may affect the likelihood of impact and/or the consequences of failure.

Tree risk has two components: (1) the likelihood of a tree failure striking a target, which is divided into the likelihood of failure and the likelihood of impact, and (2) the consequences of failure. Use your best judgment and the data available to assess the likelihood of failure (*improbable, possible, probable, imminent*) and the likelihood of impact (*very low, low, medium, high*). After these two decisions are made, use Matrix 1 for guidance on choosing the likelihood of failure and impact category (*unlikely, somewhat likely, likely, very likely*).

The likelihood of failure can be categorized using the following guidelines:

Improbable—the tree or branch is not likely to fail during normal weather conditions and may not fail in many severe weather conditions within the specified time frame.

Possible—failure could occur, but it is unlikely during normal weather conditions within the specified time frame.

Probable—failure may be expected under normal weather conditions within the specified time frame.

Imminent—failure has started or is most likely to occur in the near future, even if there is no significant wind or increased load. This is a rare occurrence for a risk assessor to encounter, and it may require immediate action to protect people from harm.

Since these categories are time dependent, the time frame must be considered. The time frame is recorded on the first page.

The likelihood of impacting a target can be categorized using the following guidelines:

Very low—the chance of the failed tree or branch impacting the specified target is remote. This is the case in a rarely used site fully exposed to the assessed tree or an occasionally used site that is partially protected by trees or structures. Examples include a rarely used trail or trail head in a rural area, or an occasionally used area that has some protection against being struck by the tree failure due to the presence of other trees between the tree being assessed and the targets.

Low—it is not likely that the failed tree or branch will impact the target. This is the case in an occasionally used area that is fully exposed to the assessed tree, a frequently used area that is partially exposed to the assessed tree, or a constant target that is well protected from the assessed tree. Examples include a little-used service road next to the assessed tree or a frequently used public street that has a street tree between the street and the assessed tree.

Medium—the failed tree or branch may or may not impact the target, with nearly equal likelihood. This is the case in a frequently used area that is fully exposed on one side to the assessed tree or a constantly occupied area that is partially protected from the assessed tree. Examples include a suburban street next to the assessed street tree or a house that is partially protected from the assessed tree by an intermediate tree.

High—The failed tree or branch will most likely impact the target. This is the case when a fixed target is fully exposed to the assessed tree or near a high-use road or walkway with an adjacent street tree.

After determining the likelihood of failure and the likelihood of impacting a target, the combined likelihood of a failure impacting a target can be categorized. Matrix 1 can be used as a guide in relating these likelihood factors within a given time frame. The resulting terms (*unlikely, somewhat likely, likely, very likely*) are defined by their use within the table and are used to represent this combination of occurrences in Matrix 2.

Within the Consequences section, one category should be selected (*negligible, minor, significant, severe*). Consequences of failure are estimated based on the amount of harm or damage that will be done to a target. The consequences depend on the part size, fall characteristics, fall distance, and any factors that may protect the risk target from harm. The significance of target values—both monetary and otherwise—are subjective and relative to the client.

The consequences of failure can be categorized using the following guidelines:

Negligible—low-value property damage or disruption that can be replaced or repaired, and do not involve personal injury.

Minor—low-to-moderate property damage or small disruptions to traffic or a communication utility.

Significant—property damage of moderate- to high-value, considerable disruption, or personal injury.

Severe—serious personal injury or death, damage to high-value property, or disruption of important activities.

Risk rating of part—the risk rating of the individual part for a specified target; the risk rating is categorized using Matrix 2: Risk rating matrix. Risk rating terms are *low, moderate, high, and extreme*.

Section 8—Notes, Mitigation and Limitations

<p>Notes, explanations, descriptions _____</p> <p>_____</p> <p>_____</p> <p>_____</p>		
<p>Mitigation options _____</p> <p>_____</p> <p>_____</p>		<p>Residual risk _____</p> <p>Residual risk _____</p> <p>Residual risk _____</p> <p>Residual risk _____</p>
<p>Overall tree risk rating Low <input type="checkbox"/> Moderate <input type="checkbox"/> High <input type="checkbox"/> Extreme <input type="checkbox"/></p> <p>Overall residual risk Low <input type="checkbox"/> Moderate <input type="checkbox"/> High <input type="checkbox"/> Extreme <input type="checkbox"/></p> <p>Data <input type="checkbox"/>Final <input type="checkbox"/>Preliminary Advanced assessment needed <input type="checkbox"/>No <input type="checkbox"/>Yes-Type/Reason _____</p> <p>Inspection limitations <input type="checkbox"/>None <input type="checkbox"/>Visibility <input type="checkbox"/>Access <input type="checkbox"/>Vines <input type="checkbox"/>Root collar buried Describe _____</p>		<p>Work priority 1 <input type="checkbox"/> 2 <input type="checkbox"/> 3 <input type="checkbox"/> 4 <input type="checkbox"/></p> <p>Recommended inspection interval _____</p>

Upon completion of the assessment, use this section to illustrate potential areas of concern, and to offer mitigation options. Any further recommendations or notes should be included in this section.

Notes, explanations, descriptions—space provided to describe any conditions or factors that are not well described elsewhere on the form. Include notes on anything you need to take into consideration for making ratings or recommendations.

The grid, stem, and circle templates are provided for sketching any applicable details related to the tree or site.

Mitigation options—list options for mitigating each risk described. List your preferred recommendation on the first line.

Residual risk—the residual risk is for the risk remaining after the mitigation you are recommending. Residual risk can be *low*, *moderate*, *high*, or *extreme*.

Overall tree risk rating—the highest risk determined for the tree and target of concern. If there is more than one part or target rating, the tree risk rating is the highest of the group.

Work priority—recommendation for priority of mitigation action(s). The priority aids in communicating the urgency of mitigation for an individual tree. This may be a number (e.g., 1, 2, 3, 4) or you may assign words (e.g., immediate, as soon as possible, when the workload allows; or immediate, high, medium, low). Numbers have been included on the datasheet, with “1” meaning the highest priority.

The shaded rows in the Risk Categorization chart may be used to assess residual risk after proposed mitigation. For each mitigation action, rate the expected risk remaining after treatment using the same methodology for categorizing risk as before.

Overall residual risk—risk remaining if the highest-risk tree part is mitigated.

Recommended inspection interval—recommended time for reinspection or inspection frequency.

Data—use these boxes to indicate whether this assessment is final or preliminary.

Advanced assessment needed—note the reason for any advanced assessment recommended.

Inspection limitations—note and/or describe any factors that limited your ability to inspect the tree, or check “none.”

ISA Basic Tree Risk Assessment Form

Client _____ Date _____ Time _____
 Address/Tree location _____ Tree no. _____ Sheet _____ of _____
 Tree species _____ dbh _____ Height _____ Crown spread dia. _____
 Assessor(s) _____ Time frame _____ Tools used _____

Target Assessment

Target number	Target description	Target zone			Occupancy rate 1 - rare 2 - occasional 3 - frequent 4 - constant	Practical to move target?	Restriction practical?
		Target within drip line	Target within 1 x Ht.	Target within 1.5 x Ht.			
1							
2							
3							
4							

Site Factors

History of failures _____ **Topography** Flat Slope _____ % **Aspect** _____
Site changes None Grade change Site clearing Changed soil hydrology Root cuts Describe _____
Soil conditions Limited volume Saturated Shallow Compacted Pavement over roots _____ % Describe _____
Prevailing wind direction _____ **Common weather** Strong winds Ice Snow Heavy rain Describe _____

Tree Health and Species Profile

Vigor Low Normal High **Foliage** None (seasonal) None (dead) Normal _____ % Chlorotic _____ % Necrotic _____ %
Pests _____ **Abiotic** _____
Species failure profile Branches Trunk Roots Describe _____

Load Factors

Wind exposure Protected Partial Full Wind funneling _____ **Relative crown size** Small Medium Large
Crown density Sparse Normal Dense **Interior branches** Few Normal Dense **Vines/Mistletoe/Moss** _____
Recent or planned change in load factors _____

Tree Defects and Conditions Affecting the Likelihood of Failure

— Crown and Branches —

Unbalanced crown LCR _____ %
 Dead twigs/branches _____ % overall Max. dia. _____
 Broken/Hangers Number _____ Max. dia. _____
 Over-extended branches
Pruning history
 Crown cleaned Thinned Raised
 Reduced Topped Lion-tailed
 Flush cuts Other _____
 Cracks _____ Lightning damage
 Codominant _____ Included bark
 Weak attachments _____ Cavity/Nest hole _____ % circ.
 Previous branch failures _____ Similar branches present
 Dead/Missing bark Cankers/Galls/Burls Sapwood damage/decay
 Conks Heartwood decay _____
 Response growth _____

Main concern(s) _____
Load on defect N/A Minor Moderate Significant _____
Likelihood of failure Improbable Possible Probable Imminent _____

— Trunk —

Dead/Missing bark Abnormal bark texture/color
 Codominant stems Included bark Cracks
 Sapwood damage/decay Cankers/Galls/Burls Sap ooze
 Lightning damage Heartwood decay Conks/Mushrooms
 Cavity/Nest hole _____ % circ. Depth _____ Poor taper
 Lean _____ ° Corrected? _____

Response growth _____
 Main concern(s) _____
Load on defect N/A Minor Moderate Significant
Likelihood of failure Improbable Possible Probable Imminent

— Roots and Root Collar —

Collar buried/Not visible Depth _____ Stem girdling
 Dead Decay Conks/Mushrooms
 Ooze Cavity _____ % circ.
 Cracks Cut/Damaged roots Distance from trunk _____
 Root plate lifting Soil weakness

Response growth _____
 Main concern(s) _____
Load on defect N/A Minor Moderate Significant
Likelihood of failure Improbable Possible Probable Imminent

Risk Categorization																					
Condition number	Tree part	Conditions of concern	Part size	Fall distance	Target number	Target protection	Likelihood							Consequences				Risk rating of part (from Matrix 2)			
							Failure				Impact			Failure & Impact (from Matrix 1)			Negligible		Minor	Significant	Severe
							Improbable	Possible	Probable	Imminent	Very low	Low	Medium	High	Unlikely	Somewhat					
1																					
2																					
3																					
4																					

Matrix 1. Likelihood matrix.

Likelihood of Failure	Likelihood of Impacting Target			
	Very low	Low	Medium	High
Imminent	Unlikely	Somewhat likely	Likely	Very likely
Probable	Unlikely	Unlikely	Somewhat likely	Likely
Possible	Unlikely	Unlikely	Unlikely	Somewhat likely
Improbable	Unlikely	Unlikely	Unlikely	Unlikely

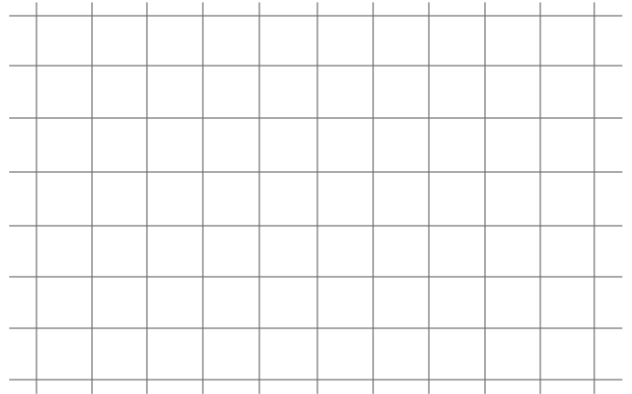

Matrix 2. Risk rating matrix.

Likelihood of Failure & Impact	Consequences of Failure			
	Negligible	Minor	Significant	Severe
Very likely	Low	Moderate	High	Extreme
Likely	Low	Moderate	High	High
Somewhat likely	Low	Low	Moderate	Moderate
Unlikely	Low	Low	Low	Low

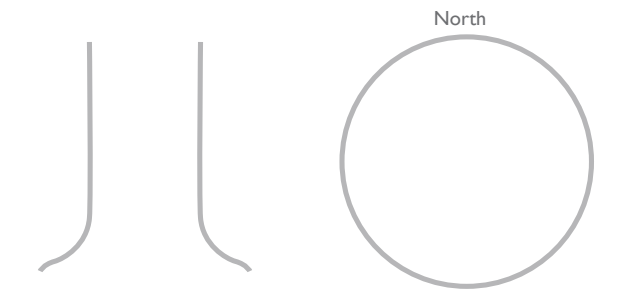

Notes, explanations, descriptions _____

Mitigation options _____ Residual risk _____
 _____ Residual risk _____
 _____ Residual risk _____
 _____ Residual risk _____

Overall tree risk rating Low Moderate High Extreme Work priority 1 2 3 4
 Overall residual risk Low Moderate High Extreme Recommended inspection interval _____

Data Final Preliminary Advanced assessment needed No Yes-Type/Reason _____
 Inspection limitations None Visibility Access Vines Root collar buried Describe _____

APPENDIX E: Tree Protection Fence

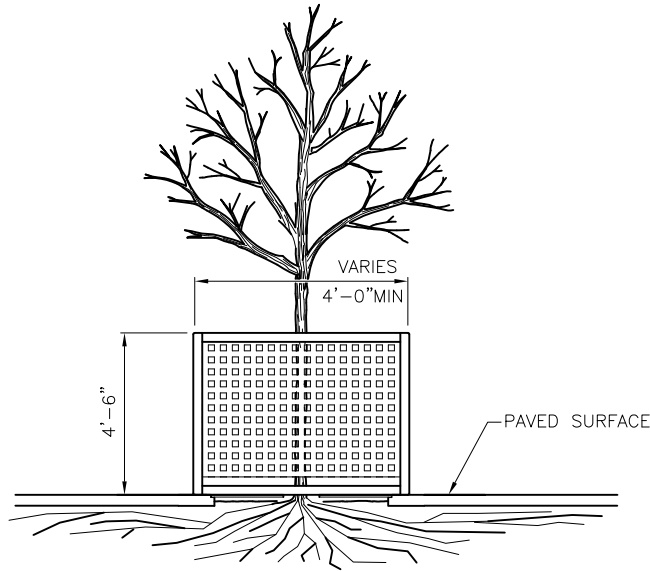

TYPICAL TREE GUARD RAIL

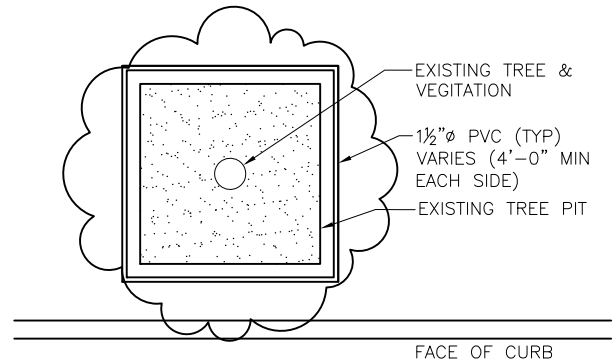

PLAN VIEW

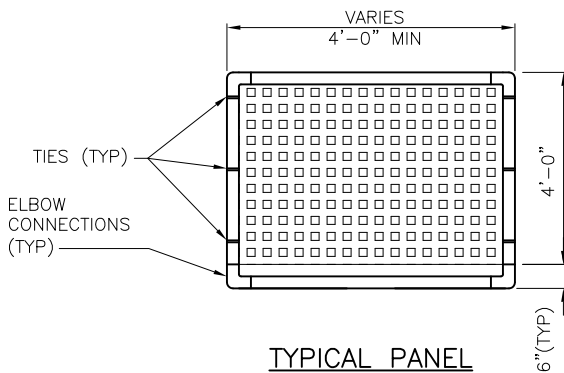

TYPICAL PANEL

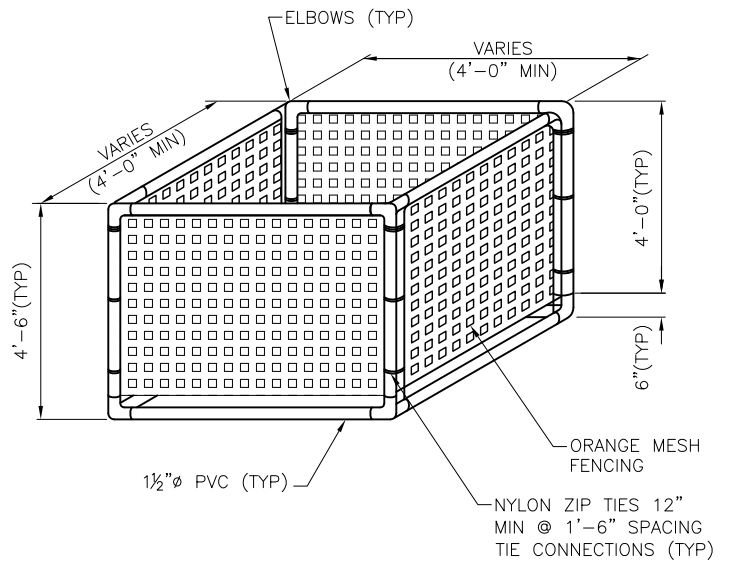

REF STD SPEC SEC 1-07.16(2) & 8-01



City of Seattle

NOT TO SCALE

REUSABLE TEMPORARY TREE & LANDSCAPE PROTECTION FENCE

APPENDIX F:

Tree Service Provider Registration Form



**Seattle Department of Transportation
Street Use & Urban Forestry Division**
700 Fifth Avenue, Suite 2300 | P.O. Box 34996
Seattle, Washington 98124-4996
(206) 684-5253 | (206) 684-TREE
Seattle.Trees@seattle.gov

SDOT Permit Number(s)

Intake

Review

(Official Use Only)

TREE SERVICE PROVIDER REGISTRATION

Seattle Municipal Code (SMC) 15.04, 15.43

Owner Name:	Owner Phone Number:
Company Name:	Company Contact Phone Number:
Company Contact Name:	Email Address:
Mailing Address (include city, state, zip):	City of Seattle Business License Number:
	WA State L&I Registration Number:

I have read and will comply with:

- Street Tree Ordinance (SMC 15.43)
- Seattle Department of Transportation Street Tree Manual
- ANSI A-300 Pruning Standards
- City of Seattle Traffic Control Manual
(see www.seattle.gov/transportation/trafficcontrolmanual.htm)

ISA Certified Arborist(s) or ISA Certified Tree Worker	ISA Certification Number	Expiration Date	TRAQ	Expiration Date
			<input type="checkbox"/> Yes <input type="checkbox"/> No	
			<input type="checkbox"/> Yes <input type="checkbox"/> No	

If your company has a list of Certified Arborists and Tree Workers, provide that list on your business letterhead.

CHECKLIST FOR DOCUMENTATION TO BE INCLUDED WITH YOUR APPLICATION

- Washington State Contractor License (L&I)
- City of Seattle Business License
- Certificate of Insurance
 - City of Seattle must be listed as additional insured. Refer to SDOT Client Assistance Memo (CAM) 2102 for detailed instructions.
- If your business has a current Street Use Annual Vehicle Permit, provide the permit number

The undersigned asserts that the facts stated in the foregoing application are true and correct.

APPLICANT SIGNATURE

DATE

SDOT VERIFICATION

(Official Use Only)

Date Approved:	Registration Number:
Date Denied:	Insurance Agency:
Reason for Denial:	Insurance Agency Phone Number:
	Urban Forestry Reviewer:

The Seattle Department of Transportation
700 5th Avenue, Suite 3800
PO Box 34996
Seattle, WA 98124-4996
(206) 684-ROAD (7623)
www.seattle.gov/transportation

