

## CHAPTER 3

# GENERAL REGULATIONS

### SECTION 301 (IFGC) GENERAL

**301.1 Scope.** This chapter shall govern the approval and installation of all *equipment* and appliances that comprise parts of the installations regulated by this code in accordance with Section ((401-2)) 103.1. See also the *International Fire Code*.

**301.1.1 Other fuels.** The requirements for combustion and dilution air for gas-fired appliances shall be governed by Section 304. The requirements for combustion and dilution air for appliances operating with fuels other than fuel gas shall be regulated by the *International Mechanical Code*. The standards for liquefied petroleum gas installations shall be the 2011 Edition of NFPA 58 (*Liquefied Petroleum Gas Code*) and the 2012 Edition of ANSI Z223.1/NFPA 54 (*National Fuel Gas Code*).

**301.2 Energy utilization.** Heating, ventilating and air-conditioning systems of all structures shall be designed and installed for efficient utilization of energy in accordance with the *International Energy Conservation Code*.

**301.3 Listed and labeled.** Appliances regulated by this code shall be *listed* and *labeled* for the application in which they are used unless otherwise *approved* in accordance with Section 105. The approval of unlisted appliances in accordance with Section 105 shall be based on *approved* engineering evaluation.

**301.4 Labeling.** Labeling shall be in accordance with the procedures set forth in Sections 301.4.1 through 301.4.2.3.

**301.4.1 Testing.** An *approved* agency shall test a representative sample of the appliances being *labeled* to the relevant standard or standards. The *approved* agency shall maintain a record of all of the tests performed. The record shall provide sufficient detail to verify compliance with the test standard.

**301.4.2 Inspection and identification.** The *approved* agency shall periodically perform an inspection, which shall be in-plant if necessary, of the appliances to be *labeled*. The inspection shall verify that the *labeled* appliances are representative of the appliances tested.

**301.4.2.1 Independent.** The agency to be *approved* shall be objective and competent. To confirm its objectivity, the agency shall disclose all possible conflicts of interest.

**301.4.2.2 Equipment.** An *approved* agency shall have adequate *equipment* to perform all required tests. The *equipment* shall be periodically calibrated.

**301.4.2.3 Personnel.** An *approved* agency shall employ experienced personnel educated in conducting, supervising and evaluating tests.

**301.5 Label information.** A permanent factory-applied nameplate(s) shall be affixed to appliances on which shall

appear in legible lettering, the manufacturer's name or trademark, the model number, serial number and, for *listed* appliances, the seal or mark of the testing agency. A label shall include the hourly rating in British thermal units per hour (Btu/h) (W); the type of fuel *approved* for use with the *appliance*; and the minimum *clearance* requirements.

**301.6 Plumbing connections.** Potable water supply and building drainage system connections to appliances regulated by this code shall be in accordance with the ((*International*)) *Uniform Plumbing Code*.

**301.7 Fuel types.** Appliances shall be designed for use with the type of fuel gas that will be supplied to them.

**301.7.1 Appliance fuel conversion.** Appliances shall not be converted to utilize a different fuel gas except where complete instructions for such conversion are provided in the installation instructions, by the serving gas supplier or by the *appliance* manufacturer.

**301.8 Vibration isolation.** Where means for isolation of vibration of an *appliance* is installed, an *approved* means for support and restraint of that *appliance* shall be provided.

**301.9 Repair.** Defective material or parts shall be replaced or repaired in such a manner so as to preserve the original approval or listing.

**301.10 Wind resistance.** Appliances and supports that are exposed to wind shall be designed and installed to resist the wind pressures determined in accordance with the *International Building Code*.

[BS] **301.11 Flood hazard.** For structures located in flood hazard areas, the appliance, equipment and system installations regulated by this code shall be located at or above the elevation required by Section 1612 of the *International Building Code* for utilities and attendant equipment.

**Exception:** The appliance, equipment and system installations regulated by this code are permitted to be located below the elevation required by Section 1612 of the *International Building Code* for utilities and attendant equipment provided that they are designed and installed to prevent water from entering or accumulating within the components and to resist hydrostatic and hydrodynamic loads and stresses, including the effects of buoyancy, during the occurrence of flooding to such elevation.

**301.12 Seismic resistance.** When earthquake loads are applicable in accordance with the *International Building Code*, the supports shall be designed and installed for the seismic forces in accordance with that code.

**301.13 Ducts.** Ducts required for the installation of systems regulated by this code shall be designed and installed in accordance with the *International Mechanical Code*.

**301.14 Rodentproofing.** Buildings or structures and the walls enclosing habitable or occupiable rooms and spaces in which persons live, sleep or work, or in which feed, food or

## GENERAL REGULATIONS

foodstuffs are stored, prepared, processed, served or sold, shall be constructed to protect against rodents in accordance with the *International Building Code*.

**301.15 Prohibited location.** The appliances, *equipment* and systems regulated by this code shall not be located in an elevator shaft.

### SECTION 302 (IFGC) STRUCTURAL SAFETY

**[BS] 302.1 Structural safety.** The building shall not be weakened by the installation of any gas *pipng*. In the process of installing or repairing any gas *pipng*, the finished floors, walls, ceilings, tile work or any other part of the building or premises which is required to be changed or replaced shall be left in a safe structural condition in accordance with the requirements of the *International Building Code*.

**[BF] 302.2 Penetrations of floor/ceiling assemblies and fire-resistance-rated assemblies.** Penetrations of floor/ceiling assemblies and assemblies required to have a fire-resistance rating shall be protected in accordance with the *International Building Code*.

**[BS] 302.3 Cutting, notching and boring in wood members.** The cutting, notching and boring of wood members shall comply with Sections 302.3.1 through 302.3.4.

**[BS] 302.3.1 Engineered wood products.** Cuts, notches and holes bored in trusses, structural composite lumber, structural glued-laminated members and I-joists are prohibited except where permitted by the manufacturer's recommendations or where the effects of such alterations are specifically considered in the design of the member by a registered design professional.

**[BS] 302.3.2 Joist notching and boring.** Notching at the ends of joists shall not exceed one-fourth the joist depth. Holes bored in joists shall not be within 2 inches (51 mm) of the top and bottom of the joist and their diameters shall not exceed one-third the depth of the member. Notches in the top or bottom of the joist shall not exceed one-sixth the depth and shall not be located in the middle one-third of the span.

**[BS] 302.3.3 Stud cutting and notching.** In exterior walls and bearing partitions, any wood stud is permitted to be cut or notched to a depth not exceeding 25 percent of its width. Cutting or notching of studs to a depth not greater than 40 percent of the width of the stud is permitted in nonload-bearing partitions supporting no loads other than the weight of the partition.

**[BS] 302.3.4 Bored holes.** The diameter of bored holes in wood studs shall not exceed 40 percent of the stud depth. The diameter of bored holes in wood studs shall not exceed 60 percent of the stud depth in nonbearing partitions. The diameter of bored holes in wood studs shall not exceed 60 percent of the stud depth in any wall where each stud is doubled, provided that not more than two such successive doubled studs are so bored. The edge of the bored hole shall be not closer than  $\frac{5}{8}$  inch (15.9 mm) to the edge of the stud. Bored holes shall not be located at the same section of stud as a cut or notch.

**[BS] 302.4 Alterations to trusses.** Truss members and components shall not be cut, drilled, notched, spliced or otherwise altered in any way without the written concurrence and approval of a registered design professional. Alterations resulting in the addition of loads to any member, such as HVAC *equipment* and water heaters, shall not be permitted without verification that the truss is capable of supporting such additional loading.

**[BS] 302.5 Cutting, notching and boring holes in structural steel framing.** The cutting, notching and boring of holes in structural steel framing members shall be as prescribed by the registered design professional.

**[BS] 302.6 Cutting, notching and boring holes in cold-formed steel framing.** Flanges and lips of load-bearing, cold-formed steel framing members shall not be cut or notched. Holes in webs of load-bearing, cold-formed steel framing members shall be permitted along the centerline of the web of the framing member and shall not exceed the dimensional limitations, penetration spacing or minimum hole edge distance as prescribed by the registered design professional. Cutting, notching and boring holes of steel floor/roof decking shall be as prescribed by the registered design professional.

**[BS] 302.7 Cutting, notching and boring holes in non-structural cold-formed steel wall framing.** Flanges and lips of nonstructural cold-formed steel wall studs shall be permitted along the centerline of the web of the framing member, shall not exceed  $1\frac{1}{2}$  inches (38 mm) in width or 4 inches (102 mm) in length, and the holes shall not be spaced less than 24 inches (610 mm) center to center from another hole or less than 10 inches (254 mm) from the bearing end.

### SECTION 303 (IFGC) APPLIANCE LOCATION

**303.1 General.** Appliances shall be located as required by this section, specific requirements elsewhere in this code and the conditions of the *equipment* and *appliance* listing.

**303.2 Hazardous locations.** Appliances shall not be located in a *hazardous location* unless *listed* and *approved* for the specific installation.

**303.3 Prohibited locations.** Appliances shall not be located in sleeping rooms, bathrooms, toilet rooms, storage closets or surgical rooms, or in a space that opens only into such rooms or spaces, except where the installation complies with one of the following:

1. The *appliance* is a direct-vent *appliance* installed in accordance with the conditions of the listing and the manufacturer's instructions.
2. Vented room heaters, wall furnaces, vented decorative appliances, vented gas fireplaces, vented gas fireplace heaters and decorative appliances for installation in vented solid fuel-burning fireplaces are installed in rooms that meet the required volume criteria of Section 304.5.
3. A single wall-mounted unvented room heater is installed in a bathroom and such unvented room heater

is equipped as specified in Section 621.6 and has an input rating not greater than 6,000 Btu/h (1.76 kW). The bathroom shall meet the required volume criteria of Section 304.5.

4. A single wall-mounted unvented room heater is installed in a bedroom and such unvented room heater is equipped as specified in Section 621.6 and has an input rating not greater than 10,000 Btu/h (2.93 kW). The bedroom shall meet the required volume criteria of Section 304.5.
5. The *appliance* is installed in a room or space that opens only into a bedroom or bathroom, and such room or space is used for no other purpose and is provided with a solid weather-stripped door equipped with an *approved* self-closing device. All *combustion air* shall be taken directly from the outdoors in accordance with Section 304.6.

**303.4 Protection from vehicle impact damage.** Appliances shall not be installed in a location subject to vehicle impact damage except where protected by an *approved* means.

**303.5 Indoor locations.** Furnaces and boilers installed in closets and alcoves shall be *listed* for such installation.

**303.6 Outdoor locations.** Appliances installed in outdoor locations shall be either *listed* for outdoor installation or provided with protection from outdoor environmental factors that influence the operability, durability and safety of the appliances.

**303.7 Pit locations.** Appliances installed in pits or excavations shall not come in direct contact with the surrounding soil. The sides of the pit or excavation shall be held back a minimum of 12 inches (305 mm) from the *appliance*, and a minimum of 30 inches (762 mm) on the control side. Where the depth exceeds 12 inches (305 mm) below adjoining grade, the walls of the pit or excavation shall be lined with concrete or masonry, such concrete or masonry shall extend a minimum of 4 inches (102 mm) above adjoining grade and shall have sufficient lateral load-bearing capacity to resist collapse. The *appliance* shall be protected from flooding in an *approved* manner.

**[B] 303.8 Installation of pipes or ducts conveying gases, vapors or liquids in hoistways, machine rooms or machinery spaces.** Pipes and ducts conveying gases, vapors or liquids are not permitted to be installed in elevator hoistways, elevator machine rooms and elevator machinery spaces.

**Exceptions:**

1. Only ducts for heating, cooling, ventilating and venting these spaces are permitted to be installed in the hoistway, machine room and machinery space.
2. Ducts and electrical conduit may pass through an elevator machine room or machinery space provided they are separate from the room or space by construction equal to the rated construction of the room or space and located so that all required clearances are maintained.

If a vented machine room is not vented directly to the outside of the building, the vent shall be enclosed within a fire barrier with at least a one-hour fire-resis-

tance rating, or as required for shafts where it passes through occupied floors.

3. Subject to the approval of the code official, pipes protected with double containment and pipes with threaded or welded joints may be permitted. Pipes shall not be located less than 7 feet (2134 mm) above the floor in machine rooms.

**[B] 303.9 Interior exit stairways and exit passageways.** Mechanical systems shall not be located in interior exit stairways and exit passageways. Penetrations passing entirely through both protective membranes are prohibited.

## SECTION 304 (IFGS)

### COMBUSTION, VENTILATION AND DILUTION AIR

**304.1 General.** Air for combustion, ventilation and dilution of flue gases for appliances installed in buildings shall be provided by application of one of the methods prescribed in Sections 304.5 through 304.9. Where the requirements of Section 304.5 are not met, outdoor air shall be introduced in accordance with one of the methods prescribed in Sections 304.6 through 304.9. *Direct-vent appliances*, gas appliances of other than natural draft design, vented gas appliances not designated as Category I and appliances equipped with power burners shall be provided with combustion, ventilation and dilution air in accordance with the *appliance* manufacturer's instructions.

**Exception:** Type 1 clothes dryers that are provided with makeup air in accordance with Section 614.6.

**304.2 Appliance location.** Appliances shall be located so as not to interfere with proper circulation of combustion, ventilation and dilution air.

**304.3 Draft hood/regulator location.** Where used, a draft hood or a barometric draft regulator shall be installed in the same room or enclosure as the *appliance* served to prevent any difference in pressure between the hood or regulator and the *combustion air* supply.

**304.4 Makeup air provisions.** Where exhaust fans, clothes dryers and kitchen ventilation systems interfere with the operation of appliances, makeup air shall be provided.

**304.5 Indoor combustion air.** The required volume of indoor air shall be determined in accordance with Section 304.5.1 or 304.5.2, except that where the air infiltration rate is known to be less than 0.40 air changes per hour (ACH), Section 304.5.2 shall be used. The total required volume shall be the sum of the required volume calculated for all appliances located within the space. Rooms communicating directly with the space in which the appliances are installed through openings not furnished with doors, and through *combustion air* openings sized and located in accordance with Section 304.5.3, are considered to be part of the required volume.

**304.5.1 Standard method.** The minimum required volume shall be 50 cubic feet per 1,000 Btu/h (4.8 m<sup>3</sup>/kW) of the *appliance* input rating.

**304.5.2 Known air-infiltration-rate method.** Where the air infiltration rate of a structure is known, the minimum required volume shall be determined as follows:

**GENERAL REGULATIONS**

For appliances other than fan-assisted, calculate volume using Equation 3-1.

$$Required\ Volume_{other} \geq \frac{21\ ft^3}{ACH} \left( \frac{I_{other}}{1,000\ Btu/h} \right)$$

**(Equation 3-1)**

For fan-assisted appliances, calculate volume using Equation 3-2.

$$Required\ Volume_{fan} \geq \frac{15\ ft^3}{ACH} \left( \frac{I_{fan}}{1,000\ Btu/h} \right)$$

**(Equation 3-2)**

where:

$I_{other}$  = All appliances other than fan assisted (input in Btu/h).

$I_{fan}$  = Fan-assisted appliance (input in Btu/h).

$ACH$  = Air change per hour (percent of volume of space exchanged per hour, expressed as a decimal).

For purposes of this calculation, an infiltration rate greater than 0.60  $ACH$  shall not be used in Equations 3-1 and 3-2.

**304.5.3 Indoor opening size and location.** Openings used to connect indoor spaces shall be sized and located in accordance with Sections 304.5.3.1 and 304.5.3.2 (see Figure 304.5.3).

**304.5.3.1 Combining spaces on the same story.** Each opening shall have a minimum free area of 1 square

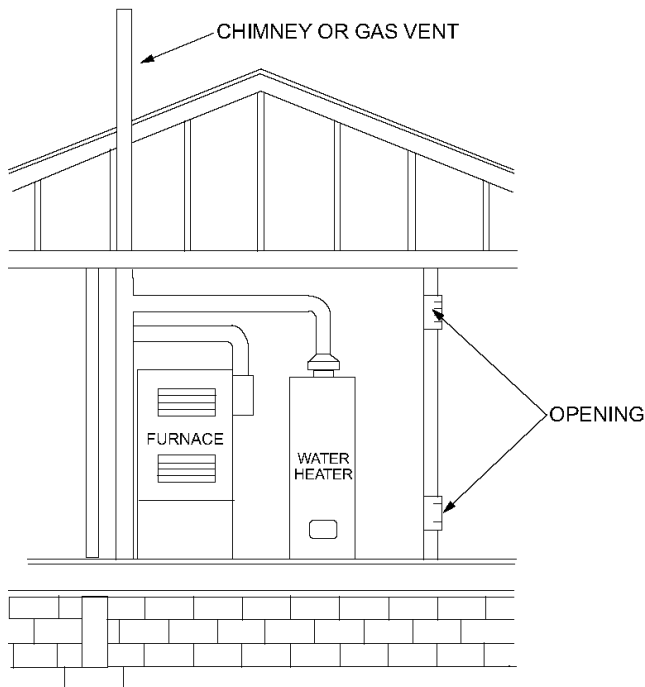
inch per 1,000 Btu/h (2,200 mm<sup>2</sup>/kW) of the total input rating of all appliances in the space, but not less than 100 square inches (0.06 m<sup>2</sup>). One opening shall commence within 12 inches (305 mm) of the top and one opening shall commence within 12 inches (305 mm) of the bottom of the enclosure. The minimum dimension of air openings shall be not less than 3 inches (76 mm).

**304.5.3.2 Combining spaces in different stories.** The volumes of spaces in different stories shall be considered as communicating spaces where such spaces are connected by one or more openings in doors or floors having a total minimum free area of 2 square inches per 1,000 Btu/h (4402 mm<sup>2</sup>/kW) of total input rating of all appliances.

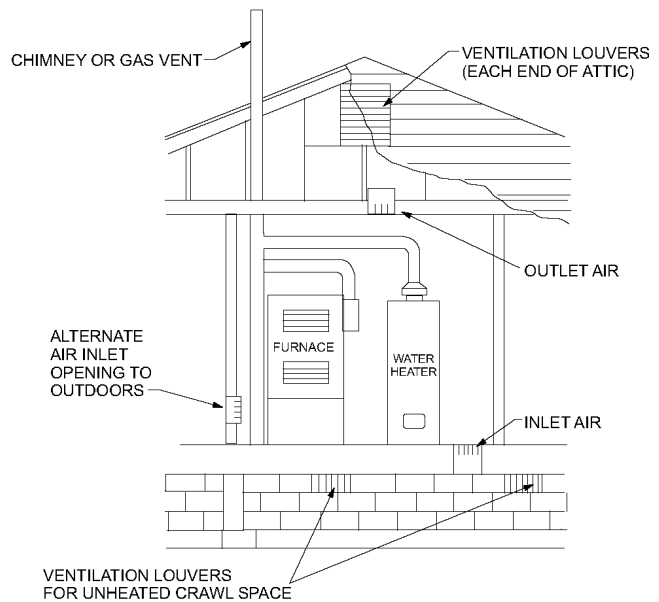
**304.6 Outdoor combustion air.** Outdoor combustion air shall be provided through opening(s) to the outdoors in accordance with Section 304.6.1 or 304.6.2. The minimum dimension of air openings shall be not less than 3 inches (76 mm).

**304.6.1 Two-permanent-openings method.** Two permanent openings, one commencing within 12 inches (305 mm) of the top and one commencing within 12 inches (305 mm) of the bottom of the enclosure, shall be provided. The openings shall communicate directly or by ducts with the outdoors or spaces that freely communicate with the outdoors.

Where directly communicating with the outdoors, or where communicating with the outdoors through vertical ducts, each opening shall have a minimum free area of 1 square inch per 4,000 Btu/h (550 mm<sup>2</sup>/kW) of total input rating of all appliances in the enclosure [see Figures 304.6.1(1) and 304.6.1(2)].

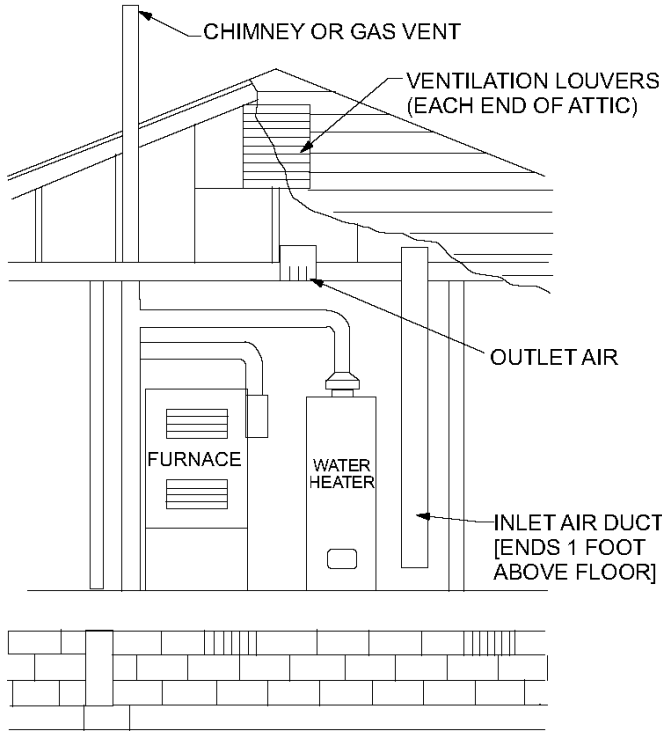


**FIGURE 304.5.3**  
ALL AIR FROM INSIDE THE BUILDING  
(see Section 304.5.3)



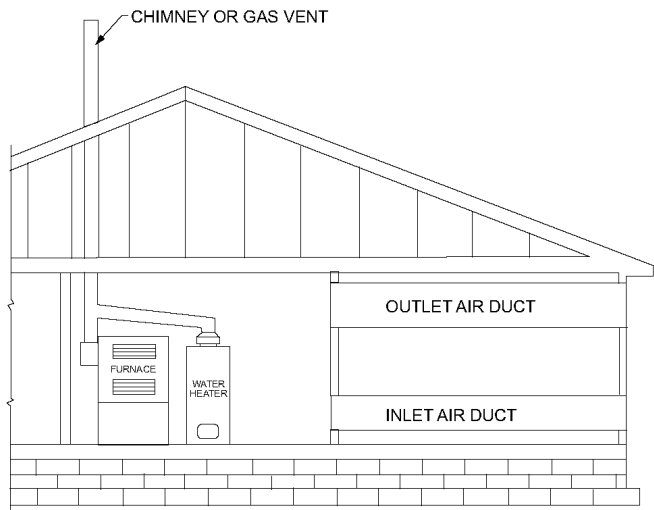
**FIGURE 304.6.1(1)**  
ALL AIR FROM OUTDOORS—INLET AIR FROM VENTILATED  
CRAWL SPACE AND OUTLET AIR TO VENTILATED ATTIC  
(see Section 304.6.1)

Where communicating with the outdoors through horizontal ducts, each opening shall have a minimum free area of not less than 1 square inch per 2,000 Btu/h (1,100 mm<sup>2</sup>/kW) of total input rating of all appliances in the enclosure [see Figure 304.6.1(3)].



For SI: 1 foot = 304.8 mm.

**FIGURE 304.6.1(2)**  
ALL AIR FROM OUTDOORS THROUGH VENTILATED ATTIC  
(see Section 304.6.1)



**FIGURE 304.6.1(3)**  
ALL AIR FROM OUTDOORS  
(see Section 304.6.1)

**304.6.2 One-permanent-opening method.** One permanent opening, commencing within 12 inches (305 mm) of the top of the enclosure, shall be provided. The *appliance* shall have clearances of not less than 1 inch (25 mm) from the sides and back and 6 inches (152 mm) from the front of the *appliance*. The opening shall directly communicate with the outdoors, or through a vertical or horizontal duct, to the outdoors or spaces that freely communicate with the outdoors (see Figure 304.6.2) and shall have a minimum free area of 1 square inch per 3,000 Btu/h (734 mm<sup>2</sup>/kW) of the total input rating of all appliances located in the enclosure and not less than the sum of the areas of all vent connectors in the space.

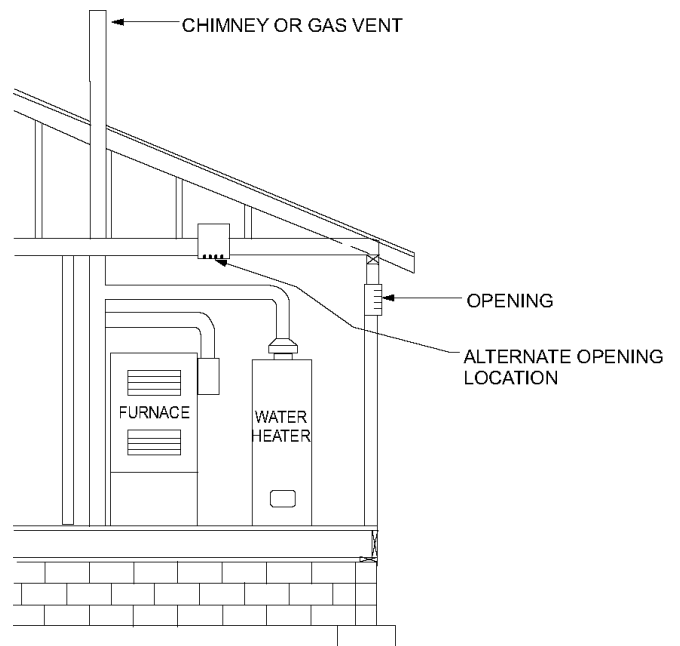
**304.7 Combination indoor and outdoor combustion air.** The use of a combination of indoor and outdoor *combustion air* shall be in accordance with Sections 304.7.1 through 304.7.3.

**304.7.1 Indoor openings.** Where used, openings connecting the interior spaces shall comply with Section 304.5.3.

**304.7.2 Outdoor opening location.** Outdoor opening(s) shall be located in accordance with Section 304.6.

**304.7.3 Outdoor opening(s) size.** The outdoor opening(s) size shall be calculated in accordance with the following:

1. The ratio of interior spaces shall be the available volume of all communicating spaces divided by the required volume.
2. The outdoor size reduction factor shall be one minus the ratio of interior spaces.
3. The minimum size of outdoor opening(s) shall be the full size of outdoor opening(s) calculated in accordance with Section 304.6, multiplied by the



**FIGURE 304.6.2**  
SINGLE COMBUSTION AIR OPENING,  
ALL AIR FROM THE OUTDOORS  
(see Section 304.6.2)

## GENERAL REGULATIONS

reduction factor. The minimum dimension of air openings shall be not less than 3 inches (76 mm).

**304.8 Engineered installations.** Engineered *combustion air* installations shall provide an adequate supply of combustion, ventilation and dilution air and shall be *approved*.

**304.9 Mechanical combustion air supply.** Where all *combustion air* is provided by a mechanical air supply system, the *combustion air* shall be supplied from the outdoors at a rate not less than 0.35 cubic feet per minute per 1,000 Btu/h (0.034 m<sup>3</sup>/min per kW) of total input rating of all appliances located within the space.

**304.9.1 Makeup air.** Where exhaust fans are installed, makeup air shall be provided to replace the exhausted air.

**304.9.2 Appliance interlock.** Each of the appliances served shall be interlocked with the mechanical air supply system to prevent main burner operation when the mechanical air supply system is not in operation.

**304.9.3 Combined combustion air and ventilation air system.** Where *combustion air* is provided by the building's mechanical ventilation system, the system shall provide the specified *combustion air* rate in addition to the required ventilation air.

**304.10 Louvers and grilles.** The required size of openings for combustion, ventilation and dilution air shall be based on the net free area of each opening. Where the free area through a design of louver, grille or screen is known, it shall be used in calculating the size opening required to provide the free area specified. Where the design and free area of louvers and grilles are not known, it shall be assumed that wood louvers will have 25-percent free area and metal louvers and grilles will have 75-percent free area. Screens shall have a mesh size not smaller than 1/4 inch (6.4 mm). Nonmotorized louvers and grilles shall be fixed in the open position. Motorized louvers shall be interlocked with the *appliance* so that they are proven to be in the full open position prior to main burner ignition and during main burner operation. Means shall be provided to prevent the main burner from igniting if the louvers fail to open during burner start-up and to shut down the main burner if the louvers close during operation.

**304.11 Combustion air ducts.** *Combustion air* ducts shall comply with all of the following:

1. Ducts shall be constructed of galvanized steel complying with Chapter 6 of the *International Mechanical Code* or of a material having equivalent corrosion resistance, strength and rigidity.

**Exception:** Within dwellings units, unobstructed stud and joist spaces shall not be prohibited from conveying *combustion air*, provided that not more than one required fireblock is removed.

2. Ducts shall terminate in an unobstructed space allowing free movement of *combustion air* to the appliances.
3. Ducts shall serve a single enclosure.
4. Ducts shall not serve both upper and lower *combustion air* openings where both such openings are used. The separation between ducts serving upper and lower *com-*

*bustion air* openings shall be maintained to the source of *combustion air*.

5. Ducts shall not be screened where terminating in an attic space.
6. Horizontal upper *combustion air* ducts shall not slope downward toward the source of *combustion air*.
7. The remaining space surrounding a chimney liner, gas vent, special gas vent or plastic *pipng* installed within a masonry, metal or factory-built chimney shall not be used to supply *combustion air*.

**Exception:** Direct-vent gas-fired appliances designed for installation in a solid fuel-burning *fire-place* where installed in accordance with the manufacturer's instructions.

8. *Combustion air* intake openings located on the exterior of a building shall have the lowest side of such openings located not less than 12 inches (305 mm) vertically from the adjoining finished ground level.

**304.12 Protection from fumes and gases.** Where corrosive or flammable process fumes or gases, other than products of combustion, are present, means for the disposal of such fumes or gases shall be provided. Such fumes or gases include carbon monoxide, hydrogen sulfide, ammonia, chlorine and halogenated hydrocarbons.

In barbershops, beauty shops and other facilities where chemicals that generate corrosive or flammable products, such as aerosol sprays, are routinely used, nondirect vent-type appliances shall be located in a mechanical room separated or partitioned off from other areas with provisions for *combustion air* and dilution air from the outdoors. *Direct-vent appliances* shall be installed in accordance with the *appliance* manufacturer's instructions.

## SECTION 305 (IFGC) INSTALLATION

**305.1 General.** *Equipment* and appliances shall be installed as required by the terms of their approval, in accordance with the conditions of listing, the manufacturer's instructions and this code. Manufacturers' installation instructions shall be available on the job site at the time of inspection. Where a code provision is less restrictive than the conditions of the listing of the *equipment* or *appliance* or the manufacturer's installation instructions, the conditions of the listing and the manufacturer's installation instructions shall apply.

Unlisted appliances *approved* in accordance with Section 301.3 shall be limited to uses recommended by the manufacturer and shall be installed in accordance with the manufacturer's instructions, the provisions of this code and the requirements determined by the code official.

**305.2 Hazardous area.** *Equipment* and appliances having an *ignition source* shall not be installed in Group H occupancies or control areas where open use, handling or dispensing of combustible, flammable or explosive materials occurs.

**305.3 Elevation of ignition source.** *Equipment* and appliances having an *ignition source* shall be elevated such that the source of ignition is not less than 18 inches (457 mm)

above the floor in hazardous locations and public garages, private garages, repair garages, motor fuel-dispensing facilities and parking garages. For the purpose of this section, rooms or spaces that are not part of the *living space* of a *dwelling unit* and that communicate directly with a private garage through openings shall be considered to be part of the private garage.

**Exception:** Elevation of the *ignition source* is not required for appliances that are *listed* as flammable vapor ignition resistant.

**305.3.1 (IFGS) Installation in residential garages.** In residential garages where appliances are installed in a separate, enclosed space having *access* only from outside of the garage, such appliances shall be permitted to be installed at floor level, provided that the required *combustion air* is taken from the exterior of the garage.

**305.3.2 Parking garages.** Connection of a parking garage with any room in which there is a fuel-fired *appliance* shall be by means of a vestibule providing a two-doorway separation, except that a single door is permitted where the sources of ignition in the *appliance* are elevated in accordance with Section 305.3.

**Exception:** This section shall not apply to *appliance* installations complying with Section 305.4.

**305.4 Public garages.** Appliances located in public garages, motor fuel-dispensing facilities, repair garages or other areas frequented by motor vehicles shall be installed not less than 8 feet (2438 mm) above the floor. Where motor vehicles are capable of passing under an appliance, the appliance shall be installed at the clearances required by the appliance manufacturer and not less than 1 foot (305 mm) higher than the tallest vehicle garage door opening.

**Exception:** The requirements of this section shall not apply where the appliances are protected from motor vehicle impact and installed in accordance with Section 305.3 and NFPA 30A.

**305.5 Private garages.** Appliances located in private garages shall be installed with a minimum *clearance* of 6 feet (1829 mm) above the floor.

**Exception:** The requirements of this section shall not apply where the appliances are protected from motor vehicle impact and installed in accordance with Section 305.3.

**305.6 Construction and protection.** Boiler rooms and furnace rooms shall be protected as required by the *International Building Code*.

**305.7 Clearances from grade.** *Equipment* and appliances installed at grade level shall be supported on a level concrete slab or other *approved* material extending not less than 3 inches (76 mm) above adjoining grade or shall be suspended not less than 6 inches (152 mm) above adjoining grade. Such supports shall be installed in accordance with the manufacturer's instructions.

**305.8 Clearances to combustible construction.** Heat-producing *equipment* and appliances shall be installed to maintain the required clearances to combustible construction as specified in the listing and manufacturer's instructions. Such clearances shall be reduced only in accordance with Section

308. Clearances to combustibles shall include such considerations as door swing, drawer pull, overhead projections or shelving and window swing. Devices, such as door stops or limits and closers, shall not be used to provide the required clearances.

**305.9 (IFGS) Parking structures.** Appliances installed in enclosed, basement and underground parking structures shall be installed in accordance with NFPA 88A.

**305.10 (IFGS) Repair garages.** Appliances installed in repair garages shall be installed in accordance with NFPA 30A.

**305.11 (IFGS) Installation in aircraft hangars.** Heaters in aircraft hangars shall be installed in accordance with NFPA 409.

**305.12 (IFGS) Avoid strain on gas piping.** Appliances shall be supported and connected to the *piping* so as not to exert undue strain on the connections.

## SECTION 306 (IFGC) ACCESS AND SERVICE SPACE

**[M] 306.1 Access for maintenance and replacement.** Appliances, control devices, heat exchangers and HVAC components that utilize energy shall be accessible for inspection, service, repair and replacement without disabling the function of a fire-resistance-rated assembly or removing permanent construction, other appliances, or any other *piping* or ducts not connected to the *appliance* being inspected, serviced, repaired or replaced. A level working space not less than 30 inches (762 mm) deep and 30 inches (762 mm) wide shall be provided in front of the control side to service an *appliance*.

**[M] 306.2 Appliances in rooms.** Rooms containing appliances shall be provided with a door and an unobstructed passageway measuring not less than 36 inches (914 mm) wide and 80 inches (2032 mm) high.

**Exception:** Within a *dwelling unit*, appliances installed in a compartment, alcove, basement or similar space shall be provided with *access* by an opening or door and an unobstructed passageway measuring not less than 24 inches (610 mm) wide and large enough to allow removal of the largest *appliance* in the space, provided that a level service space of not less than 30 inches (762 mm) deep and the height of the *appliance*, but not less than 30 inches (762 mm), is present at the front or service side of the *appliance* with the door open.

**[M] 306.3 Appliances in attics.** Attics containing appliances shall be provided with an opening and unobstructed passageway large enough to allow removal of the largest *appliance*. The passageway shall be not less than 30 inches (762 mm) high and 22 inches (559 mm) wide and not more than 20 feet (6096 mm) in length measured along the centerline of the passageway from the opening to the *appliance*. The passageway shall have continuous solid flooring not less than 24 inches (610 mm) wide. A level service space not less than 30 inches (762 mm) deep and 30 inches (762 mm) wide shall be present at the front or service side of the *appliance*. The clear *access* opening dimensions shall be not less than 20 inches by

## GENERAL REGULATIONS

30 inches (508 mm by 762 mm) and large enough to allow removal of the largest *appliance*.

### Exceptions:

1. The passageway and level service space are not required where the *appliance* is capable of being serviced and removed through the required opening.
2. Where the passageway is not less than 6 feet (1829 mm) high for its entire length, the passageway shall be not greater than 50 feet (15 250 mm) in length.

**[M] 306.3.1 Electrical requirements.** A luminaire controlled by a switch located at the required passageway opening and a receptacle outlet shall be provided at or near the *appliance* location in accordance with ((NFPA-70)) the Seattle Electrical Code.

**[M] 306.4 Appliances under floors.** Under-floor spaces containing appliances shall be provided with an *access* opening and unobstructed passageway large enough to remove the largest *appliance*. The passageway shall be not less than 30 inches (762 mm) high and 22 inches (559 mm) wide, nor more than 20 feet (6096 mm) in length measured along the centerline of the passageway from the opening to the *appliance*. A level service space not less than 30 inches (762 mm) deep and 30 inches (762 mm) wide shall be present at the front or service side of the *appliance*. If the depth of the passageway or the service space exceeds 12 inches (305 mm) below the adjoining grade, the walls of the passageway shall be lined with concrete or masonry extending 4 inches (102 mm) above the adjoining grade and having sufficient lateral-bearing capacity to resist collapse. The clear *access* opening dimensions shall be not less than 22 inches by 30 inches (559 mm by 762 mm), and large enough to allow removal of the largest *appliance*.

### Exceptions:

1. The passageway is not required where the level service space is present when the *access* is open and the *appliance* is capable of being serviced and removed through the required opening.
2. Where the passageway is not less than 6 feet high (1829 mm) for its entire length, the passageway shall not be limited in length.

**[M] 306.4.1 Electrical requirements.** A luminaire controlled by a switch located at the required passageway opening and a receptacle outlet shall be provided at or near the *appliance* location in accordance with ((NFPA-70)) the Seattle Electrical Code.

**[M] 306.5 Equipment and appliances on roofs or elevated structures.** Where equipment or appliances requiring access ((or appliances)) are located on an elevated structure or the roof of a building such that personnel will have to climb higher than 16 feet (4877 mm) above grade to access such equipment or appliances, an interior or exterior means of access shall be provided. Such access shall not require climbing over obstructions greater than 30 inches (762 mm) in height or walking on roofs having a slope greater than 4 units vertical in 12 units horizontal (33-percent slope). Such access shall not require the use of portable ladders.

Permanent ladders installed to provide the required *access* shall comply with the following minimum design criteria:

1. The side railing shall extend above the parapet or roof edge not less than ((30)) 42 inches ((762)) 1067 mm.
2. Ladders shall have rung spacing not to exceed ((14)) 12 inches ((356)) 305 mm on center. The uppermost rung shall be not more than 24 inches (610 mm) below the upper edge of the roof hatch, roof or parapet, as applicable.
3. Ladders shall have a toe spacing not less than ((6)) 7 inches ((152)) 178 mm deep.
4. There shall be not less than 18 inches (457 mm) between rails.
5. Rungs shall have a diameter not less than 0.75-inch (19 mm) and be capable of withstanding a 300-pound (136.1 kg) load.
6. Ladders over 30 feet (9144 mm) in height shall be provided with offset sections and landings capable of withstanding 100 pounds per square foot (488.2 kg/m<sup>2</sup>). Landing dimensions shall be not less than 18 inches (457 mm) and not less than the width of the ladder served. A guard rail shall be provided on all open sides of the landing.
7. Climbing clearance. The distance from the centerline of the rungs to the nearest permanent object on the climbing side of the ladder shall be not less than 30 inches (762 mm) measured perpendicular to the rungs. This distance shall be maintained from the point of ladder access to the bottom of the roof hatch. A minimum clear width of 15 inches (381 mm) shall be provided on both sides of the ladder measured from the midpoint of and parallel with the rungs, except where cages or wells are installed.
8. Landing required. The ladder shall be provided with a clear and unobstructed bottom landing area having a minimum dimension of 30 inches by 30 inches (762 mm by 762 mm) centered in front of the ladder.
9. Ladders shall be protected against corrosion by *approved* means.
10. Access to ladders shall be provided at all times.

**Interpretation:** Item 10 allows access to ladders to be restricted to authorized personnel, and prohibits storage that blocks or restricts access to the ladder.

Catwalks installed to provide the required *access* shall be not less than 24 inches (610 mm) wide and shall have railings as required for service platforms.

**Exception:** This section shall not apply to Group R-3 occupancies.

**[M] 306.5.1 Sloped roofs.** Where appliances, *equipment*, fans or other components that require service are installed on a roof having a slope of 3 units vertical in 12 units horizontal (25-percent slope) or greater and having an edge more than 30 inches (762 mm) above grade at such edge, a level platform shall be provided on each side of the *appliance* or *equipment* to which *access* is required for service,



repair or maintenance. The platform shall be not less than 30 inches (762 mm) in any dimension and shall be provided with guards. The guards shall extend not less than 42 inches (1067 mm) above the platform, shall be constructed so as to prevent the passage of a 21-inch-diameter (533 mm) sphere and shall comply with the loading requirements for guards specified in the *International Building Code*. Access shall not require walking on roofs having a slope greater than 4 units vertical in 12 units horizontal (33-percent slope). Where access involves obstructions greater than 30 inches (762 mm) in height, such obstructions shall be provided with ladders installed in accordance with Section 306.5 or stairways installed in accordance with the requirements specified in the *International Building Code* in the path of travel to and from appliances, fans or equipment requiring service.

**[M] 306.5.2 Electrical requirements.** A receptacle outlet shall be provided at or near the *appliance* location in accordance with ((NFPA 70)) the *Seattle Electrical Code*.

**[M] 306.6 Guards.** Guards shall be provided where various components that require service and roof hatch openings are located within 10 feet (3048 mm) of a roof edge or open side of a walking surface and such edge or open side is located more than 30 inches (762 mm) above the floor, roof, or grade below. The guard shall extend not less than 30 inches (762 mm) beyond each end of components that require service. The top of the guard shall be located not less than 42 inches (1067 mm) above the elevated surface adjacent to the guard. The guard shall be constructed so as to prevent the passage of a 21-inch-diameter (533 mm) sphere and shall comply with the loading requirements for guards specified in the *International Building Code*.

**Exception:** Guards are not required where permanent fall arrest/restraint anchorage connector devices that comply with ANSI/ASSE Z 359.1 are affixed for use during the entire lifetime of the roof covering. The devices shall be re-evaluated for possible replacement when the entire roof covering is replaced. The devices shall be placed not more than 10 feet (3048 mm) on center along hip and ridge lines and placed not less than 10 feet (3048 mm) from roof edges and the open sides of walking surfaces.

### SECTION 307 (IFGC) CONDENSATE DISPOSAL

**307.1 Evaporators and cooling coils.** Condensate drainage systems shall be provided for *equipment* and appliances containing evaporators and cooling coils in accordance with the *International Mechanical Code*.

**307.2 Fuel-burning appliances.** Liquid combustion by-products of condensing appliances shall be collected, pH-neutralized and discharged to an *approved* plumbing fixture or disposal area in accordance with the manufacturer's instructions. Condensate *pipng* shall be of *approved* corrosion-resistant material and shall be not smaller than the drain connection on the *appliance*. Such *pipng* shall maintain a minimum slope in the direction of discharge of not less than

one-eighth unit vertical in 12 units horizontal (1-percent slope).

**[M] 307.3 Drain pipe materials and sizes.** Components of the condensate disposal system shall be cast iron, galvanized steel, copper, cross-linked polyethylene, polyethylene, ABS, CPVC PVC or polypropylene pipe or tubing. Components shall be selected for the pressure and temperature rating of the installation. Joints and connections shall be made in accordance with the applicable provisions of Chapter 7 of the ((*International*)) *Uniform Plumbing Code* relative to the material type. Condensate waste and drain line size shall be not less than  $\frac{3}{4}$ -inch (19 mm) internal diameter and shall not decrease in size from the drain pan connection to the place of condensate disposal. Where the drain pipes from more than one unit are manifolded together for condensate drainage, the pipe or tubing shall be sized in accordance with an *approved* method.

**307.4 Traps.** Condensate drains shall be trapped as required by the *equipment* or *appliance* manufacturer.

**307.5 Auxiliary drain pan.** Category IV condensing appliances shall be provided with an auxiliary drain pan where damage to any building component will occur as a result of stoppage in the condensate drainage system. Such pan shall be installed in accordance with the applicable provisions of Section 307 of the *International Mechanical Code*.

**Exception:** An auxiliary drain pan shall not be required for appliances that automatically shut down operation in the event of a stoppage in the condensate drainage system.

**307.6 Condensate pumps.** Condensate pumps located in uninhabitable spaces, such as attics and crawl spaces, shall be connected to the *appliance* or *equipment* served such that when the pump fails, the *appliance* or *equipment* will be prevented from operating. Pumps shall be installed in accordance with the manufacturer's instructions.

### SECTION 308 (IFGS) CLEARANCE REDUCTION

**308.1 Scope.** This section shall govern the reduction in required clearances to *combustible materials*, including gypsum board, and *combustible assemblies* for chimneys, vents, appliances, devices and equipment. Clearance requirements for air-conditioning equipment and central heating boilers and furnaces shall comply with Sections 308.3 and 308.4.

**308.2 Reduction table.** The allowable *clearance* reduction shall be based on one of the methods specified in Table 308.2 or shall utilize a reduced *clearance* protective assembly *listed* and *labeled* in accordance with UL 1618. Where required clearances are not listed in Table 308.2, the reduced clearances shall be determined by linear interpolation between the distances listed in the table. Reduced clearances shall not be derived by extrapolation below the range of the table. The reduction of the required clearances to combustibles for *listed* and *labeled* appliances and *equipment* shall be in accordance with the requirements of this section, except that such clearances shall not be reduced where reduction is specifically prohibited by the terms of the *appliance* or *equipment* listing [see Figures 308.2(1) through 308.2(3)].

**TABLE 308.2<sup>a through k</sup>**  
**REDUCTION OF CLEARANCES WITH SPECIFIED FORMS OF PROTECTION**

TYPE OF PROTECTION APPLIED TO AND COVERING ALL SURFACES OF COMBUSTIBLE MATERIAL WITHIN THE DISTANCE SPECIFIED AS THE REQUIRED CLEARANCE WITH NO PROTECTION [see Figures 308.2(1), 308.2(2), and 308.2(3)]	WHERE THE REQUIRED CLEARANCE WITH NO PROTECTION FROM APPLIANCE, VENT CONNECTOR, OR SINGLE-WALL METAL PIPE IS: (inches)									
	36		18		12		9		6	
	Allowable clearances with specified protection (inches)									
	Use Column 1 for clearances above appliance or horizontal connector. Use Column 2 for clearances from appliance, vertical connector and single-wall metal pipe.									
	Above Col. 1	Sides and rear Col. 2	Above Col. 1	Sides and rear Col. 2	Above Col. 1	Sides and rear Col. 2	Above Col. 1	Sides and rear Col. 2	Above Col. 1	Sides and rear Col. 2
1. 3 <sup>1</sup> / <sub>2</sub> -inch-thick masonry wall without ventilated airspace	—	24	—	12	—	9	—	6	—	5
2. 1/2-inch insulation board over 1-inch glass fiber or mineral wool batts	24	18	12	9	9	6	6	5	4	3
3. 0.024-inch (nominal 24 gage) sheet metal over 1-inch glass fiber or mineral wool batts reinforced with wire on rear face with ventilated airspace	18	12	9	6	6	4	5	3	3	3
4. 3 <sup>1</sup> / <sub>2</sub> -inch-thick masonry wall with ventilated airspace	—	12	—	6	—	6	—	6	—	6
5. 0.024-inch (nominal 24 gage) sheet metal with ventilated airspace	18	12	9	6	6	4	5	3	3	2
6. 1/2-inch-thick insulation board with ventilated airspace	18	12	9	6	6	4	5	3	3	3
7. 0.024-inch (nominal 24 gage) sheet metal with ventilated airspace over 0.024-inch (nominal 24 gage) sheet metal with ventilated airspace	18	12	9	6	6	4	5	3	3	3
8. 1-inch glass fiber or mineral wool batts sandwiched between two sheets 0.024-inch (nominal 24 gage) sheet metal with ventilated airspace	18	12	9	6	6	4	5	3	3	3

For SI: 1 inch = 25.4 mm, °C = [(°F - 32)/1.8], 1 pound per cubic foot = 16.02 kg/m<sup>3</sup>, 1 Btu per inch per square foot per hour per °F = 0.144 W/m<sup>2</sup> · K.

- a. Reduction of clearances from *combustible materials* shall not interfere with combustion air, draft hood clearance and relief, and accessibility of servicing.
- b. All clearances shall be measured from the outer surface of the *combustible material* to the nearest point on the surface of the appliance, disregarding any intervening protection applied to the *combustible material*.
- c. Spacers and ties shall be of *noncombustible material*. No spacer or tie shall be used directly opposite an appliance or connector.
- d. For all clearance reduction systems using a ventilated airspace, adequate provision for air circulation shall be provided as described [see Figures 308.2(2) and 308.2(3)].
- e. There shall be not less than 1 inch between clearance reduction systems and combustible walls and ceilings for reduction systems using ventilated airspace.
- f. Where a wall protector is mounted on a single flat wall away from corners, it shall have a minimum 1-inch air gap. To provide air circulation, the bottom and top edges, or only the side and top edges, or all edges shall be left open.
- g. Mineral wool batts (blanket or board) shall have a minimum density of 8 pounds per cubic foot and a minimum melting point of 1500°F.
- h. Insulation material used as part of a clearance reduction system shall have a thermal conductivity of 1.0 Btu per inch per square foot per hour per °F or less.
- i. There shall be not less than 1 inch between the appliance and the protector. In no case shall the clearance between the appliance and the combustible surface be reduced below that allowed in this table.
- j. All clearances and thicknesses are minimum; larger clearances and thicknesses are acceptable.
- k. Listed single-wall connectors shall be installed in accordance with the manufacturer’s instructions.

**308.3 Clearances for indoor air-conditioning appliances.**

*Clearance* requirements for indoor air-conditioning appliances shall comply with Sections 308.3.1 through 308.3.4.

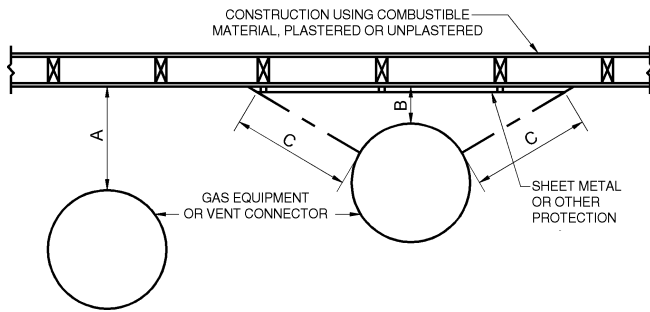
**308.3.1 Appliance clearances.** Air-conditioning appliances shall be installed with clearances in accordance with the manufacturer’s instructions.

**308.3.2 Clearance reduction.** Air-conditioning appliances shall be permitted to be installed with reduced clearances to *combustible material*, provided that the *combustible material* or *appliance* is protected as described in Table 308.2 and such reduction is allowed by the manufacturer’s instructions.

**308.3.3 Plenum clearances.** Where the *furnace plenum* is adjacent to plaster on metal lath or *noncombustible material* attached to *combustible material*, the *clearance* shall be measured to the surface of the plaster or other noncombustible finish where the *clearance* specified is 2 inches (51 mm) or less.

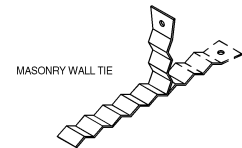
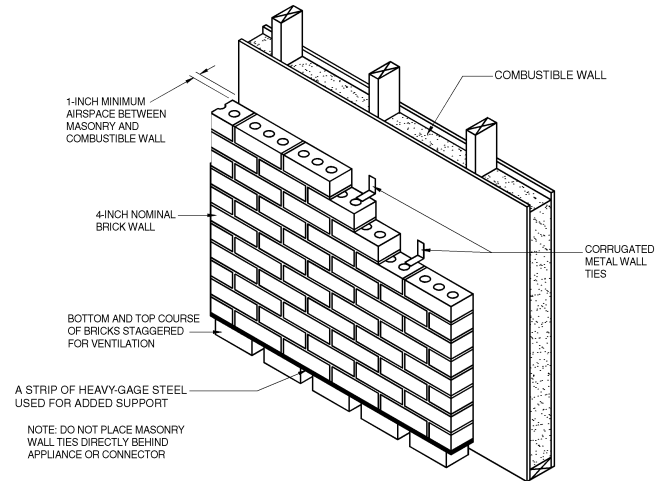
**308.3.4 Clearance from supply ducts.** Supply air ducts connecting to listed central heating furnaces shall have the same minimum clearance to combustibles as required for the furnace supply plenum for a distance of not less than 3 feet (914 mm) from the supply plenum. Clearance is not required beyond the 3-foot (914 mm) distance.

**308.4 Central-heating boilers and furnaces.** *Clearance* requirements for central-heating boilers and furnaces shall



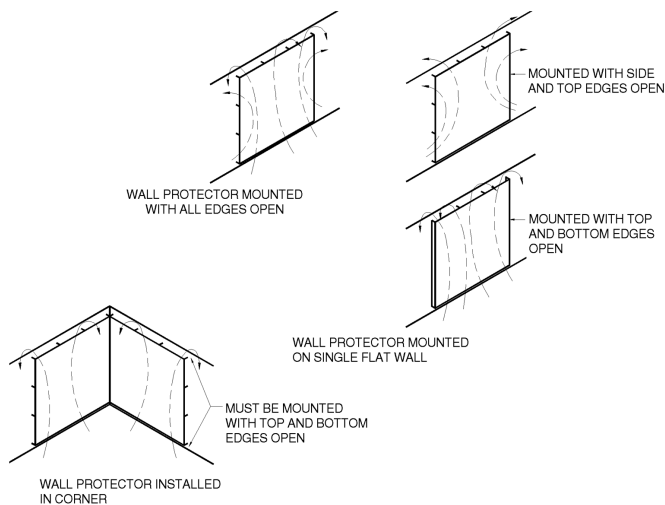
“A” equals the clearance with no protection.  
 “B” equals the reduced clearance permitted in accordance with Table 308.2.  
 The protection applied to the construction using *combustible material* shall extend far enough in each direction to make “C” equal to “A.”

**FIGURE 308.2(1)**  
**EXTENT OF PROTECTION NECESSARY TO REDUCE CLEARANCES FROM APPLIANCE OR VENT CONNECTIONS**



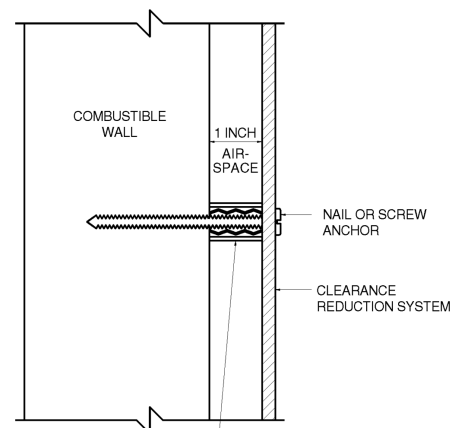
For SI: 1 inch = 25.4 mm.

**FIGURE 308.2(3)**  
**MASONRY CLEARANCE REDUCTION SYSTEM**



For SI: 1 inch = 25.4 mm.

**FIGURE 308.2(2)**  
**WALL PROTECTOR CLEARANCE REDUCTION SYSTEM**



1-INCH NONCOMBUSTIBLE SPACER SUCH AS STACKED WASHERS, SMALL-DIAMETER PIPE, TUBING OR ELECTRICAL CONDUIT.  
 MASONRY WALLS CAN BE ATTACHED TO COMBUSTIBLE WALLS USING WALL TIES.  
 DO NOT USE SPACERS DIRECTLY BEHIND APPLIANCE OR CONNECTOR.

## GENERAL REGULATIONS

comply with Sections 308.4.1 through 308.4.5. The *clearance* to these appliances shall not interfere with *combustion air*; draft hood *clearance* and relief; and accessibility for servicing.

**308.4.1 Appliance clearances.** Central-heating furnaces and low-pressure boilers shall be installed with clearances in accordance with the manufacturer's instructions.

**308.4.2 Clearance reduction.** Central-heating furnaces and low-pressure boilers shall be permitted to be installed with reduced clearances to *combustible material* provided that the *combustible material* or *appliance* is protected as described in Table 308.2 and such reduction is allowed by the manufacturer's instructions.

**308.4.3 Clearance for servicing appliances.** Front *clearance* shall be sufficient for servicing the burner and the furnace or boiler.

**308.4.4 Plenum clearances.** Where the *furnace plenum* is adjacent to plaster on metal lath or *noncombustible material* attached to *combustible material*, the *clearance* shall be measured to the surface of the plaster or other noncombustible finish where the *clearance* specified is 2 inches (51 mm) or less.

**308.4.5 Clearance from supply ducts.** Supply air ducts connecting to listed central heating furnaces shall have the same minimum clearance to combustibles as required for the furnace supply plenum for a distance of not less than 3 feet (914 mm) from the supply plenum. Clearance is not required beyond the 3-foot (914 mm) distance.

### SECTION 309 (IFGC) ELECTRICAL

**309.1 Grounding.** Gas *pipng* shall not be used as a grounding electrode.

**309.2 Connections.** Electrical connections between appliances and the building wiring, including the grounding of the appliances, shall conform to ((NFPA-70)) the *Seattle Electrical Code*.

### SECTION 310 (IFGS) ELECTRICAL BONDING

**310.1 Pipe and tubing other than CSST.** Each above-ground portion of a gas *pipng* system other than corrugated stainless steel tubing (CSST) that is likely to become energized shall be electrically continuous and bonded to an effective ground-fault current path. Gas *pipng* other than CSST shall be considered to be bonded where it is connected to appliances that are connected to the *equipment* grounding conductor of the circuit supplying that *appliance*.

**310.1.1 CSST.** Corrugated stainless steel tubing (CSST) gas *pipng* systems and piping systems containing one or more segments of CSST shall be bonded to the electrical service grounding electrode system or, where provided, the lightning protection grounding electrode system.

**310.1.1.1 Point of connection.** The bonding jumper shall connect to a metallic pipe, pipe fitting or CSST fitting.

**310.1.1.2 Size and material of jumper.** The bonding jumper shall be not smaller than 6 AWG copper wire or equivalent.

**310.1.1.3 Bonding jumper length.** The length of the bonding jumper between the connection to a gas piping system and the connection to a grounding electrode system shall not exceed 75 feet (22 860 mm). Any additional grounding electrodes used shall be bonded to the electrical service grounding electrode system or, where provided, the lightning protection grounding electrode system.

**310.1.1.4 Bonding connections.** Bonding connections shall be in accordance with NFPA 70.

**310.1.1.5 Connection devices.** Devices used for making the bonding connections shall be listed for the application in accordance with UL 467.