

**HING HAY PARK – INTERNATIONAL**

**DISTRICT**

**ADDRESS: 423 MAYNARD AVE S**

**PROPOSED WATER BOTTLE FILLING**

**STATION**

**Project Overview**

The purpose of this project is to provide clean, accessible drinking water to both the local community and visiting tourists during the FIFA World Cup. The park currently contains only the base of a former drinking fountain. We are proposing to temporarily remove this existing base and install a water bottle filling station in its place.

Given the high number of expected visitors throughout June, this temporary station will help ensure that everyone has convenient access to drinking water during the event.

This installation is intended to be fully temporary. We can remove the filling station and restore the existing fountain base back to its original condition by July 10th.

Below, you will find an image of the current base, an image of the previous fountain, our site plan, and an image of the proposed bottle-filling station (in the color Evergreen).

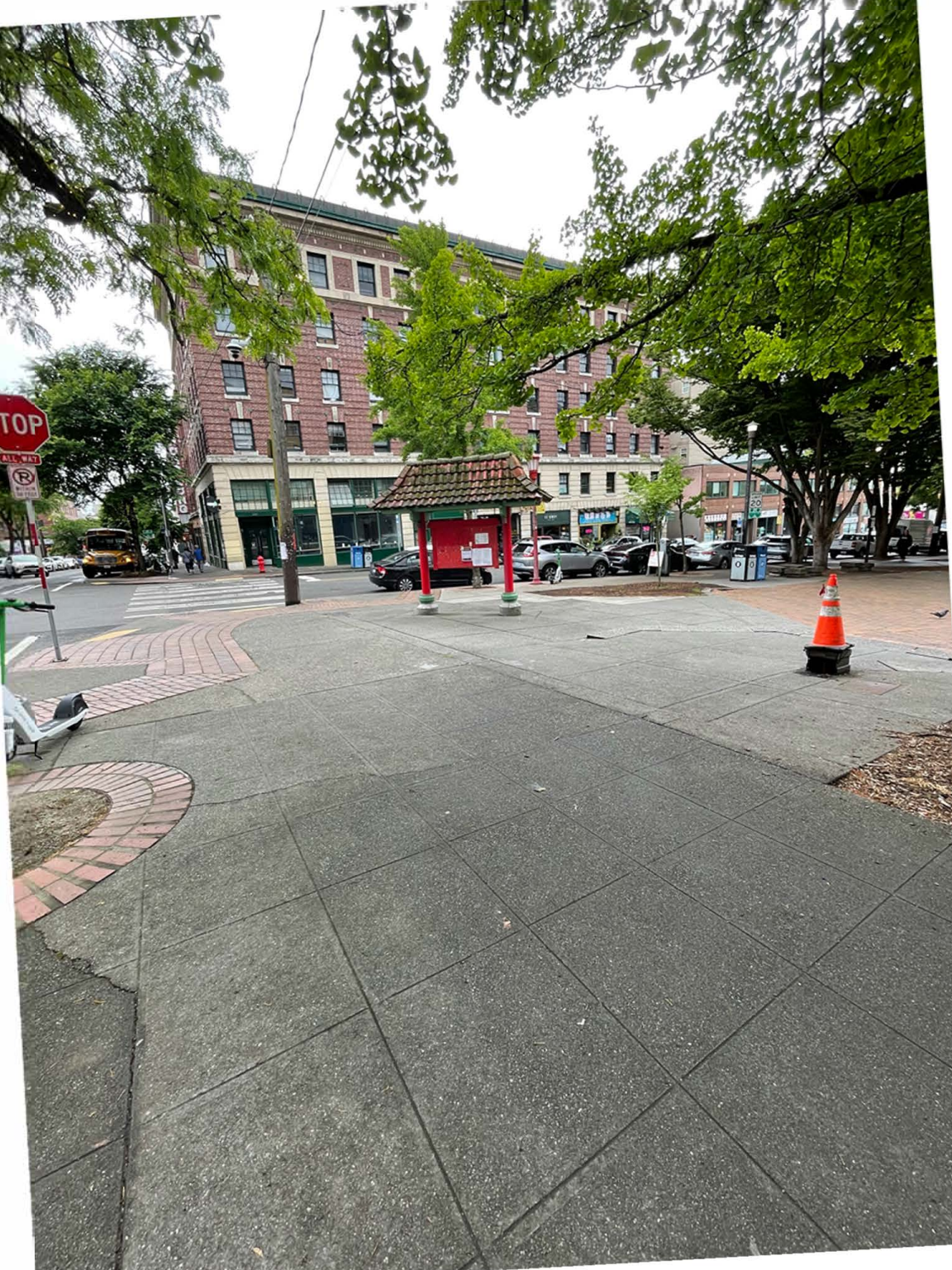

Previous fountain from 2019





38' from filler  
light pole

38' from filler  
ADA ramp on S King St.

41' from filler to  
curb edge on S King St.

34' from filler  
ADA ramp on Maynard  
Ave S

25' from filler  
curb edge on Maynard Ave S

1' from filler to  
meter box



Proposed color option is  
Evergreen



**PRODUCT SPECIFICATIONS**

Outdoor ezH2O® Bottle Filling Station Pedestal Non-Filtered Non-Refrigerated. Features shall include Heavy Duty Vandal Resistant, Laminar Flow, 300 Series Stainless. Mechanical Button activation. Product shall be Floor Mount/Freestanding, for Outdoor applications, serving 1 station(s).

<b>Special Features:</b>	Heavy Duty Vandal Resistant, Laminar Flow, 300 Series Stainless
<b>Finish:</b>	Black (BK), Blue (BLU), Evergreen (EVG), Gray (GRY)
<b>Power:</b>	No Electrical Required
<b>Bubbler Style:</b>	No Bubbler
<b>Activation by:</b>	Mechanical Button
<b>Mounting Type:</b>	Floor Mount/Freestanding
<b>Chilling Capacity:</b>	Non-refrigerated
<b>Dimensions (L x W x H):</b>	14" x 14" x 64"
<b>Approx. Shipping Weight:</b>	179 lbs.
<b>Installation Location**:</b>	Outdoor
<b>No. of Stations Served:</b>	1
**When used in non-temperature controlled environments, unit(s) must be adequately winterized and/or protected from extreme heat to prevent damage where climates dictate.	

**Special Note: To meet the full requirements for ADA please choose LK4430BF1L for adult installations and LK4430BF1M for child ADA. Bottle Filler Stations-1, Choose from 4 color options**

- Mechanically-Activated unit continues to supply water in event of service disruptions.
- Laminar flow provides clean fill with minimal splash.



**Included with Product: Outdoor Bottle Filler Ships in one box.**

A Century of Tradition and Quality. For more than 100 years, Elkay has been making innovative products and providing exceptional customer care. We take pride in offering plumbing products that make life easier, inspire change and leave the world a better place.



**PRODUCT COMPLIANCE**

ADA & ICC A117.1  
GreenSpec®  
NSF/ANSI 61 (Q≤1) & 372 (lead free)  
NSF REG4



Complies with ADA & ICC A117.1 accessibility requirements when installed according to the requirements outlined in these standards. Installation may require additional components and/or construction features to be fully compliant. Consult the local Authority Having Jurisdiction if necessary.

[Installation Instructions \(PDF\) - 1000003952](#)

**Warranty pertains to drinking water applications only. Non-drinking water applications are not covered under warranty.**

[Warranty \(PDF\)](#)

PART: \_\_\_\_\_ QTY: \_\_\_\_\_

PROJECT: \_\_\_\_\_

CONTACT: \_\_\_\_\_

DATE: \_\_\_\_\_

NOTES: \_\_\_\_\_

APPROVAL: \_\_\_\_\_

*In keeping with our policy of continuing product improvement, Elkay reserves the right to change product specifications without notice. Please visit elkay.com for the most current version of Elkay product specification sheets. This specification describes an Elkay product with design, quality, and functional benefits to the user. When making a comparison of other producers' offerings, be certain these features are not overlooked.*

Optional Accessories		
<a href="#">97890C</a>	Accessory - Direct Bury Adaptor <a href="#">Spec Sheet (PDF)</a>	
<a href="#">4481FP</a>	Outdoor Bottle Filler Foot Pedal Accessory <a href="#">Spec Sheet (PDF)</a>	

*In keeping with our policy of continuing product improvement, Elkay reserves the right to change product specifications without notice. Please visit [elkay.com](http://elkay.com) for the most current version of Elkay product specification sheets. This specification describes an Elkay product with design, quality, and functional benefits to the user. When making a comparison of other producers' offerings, be certain these features are not overlooked.*

**MOUNTING INSTRUCTIONS and PLUMBING CONNECTIONS**

Refer to diagrams for plumbing rough-in. Provide solid, well-drained smooth, flat, finished surface to mount pedestal fountain (concrete pad recommended) with adequate support (300 lb. load minimum). To secure unit, use (6) 3/8" minimum fasteners (not provided).

A service supply stop must be installed at the fountain inlet line.

Trap and service stop not included.

Position pedestal over plumbing and secure base to fasteners. Remove access panels and connect supply and water lines. Turn on water supply and check for leaks. Refer to owner's manual for detailed instructions. Reassemble access panels to pedestal.

**OPERATING PRESSURES:**  
Supply water 20 – 105 psi maximum

TOP VIEW

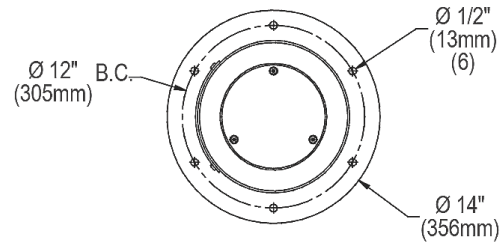

SIDE & FRONT VIEWS

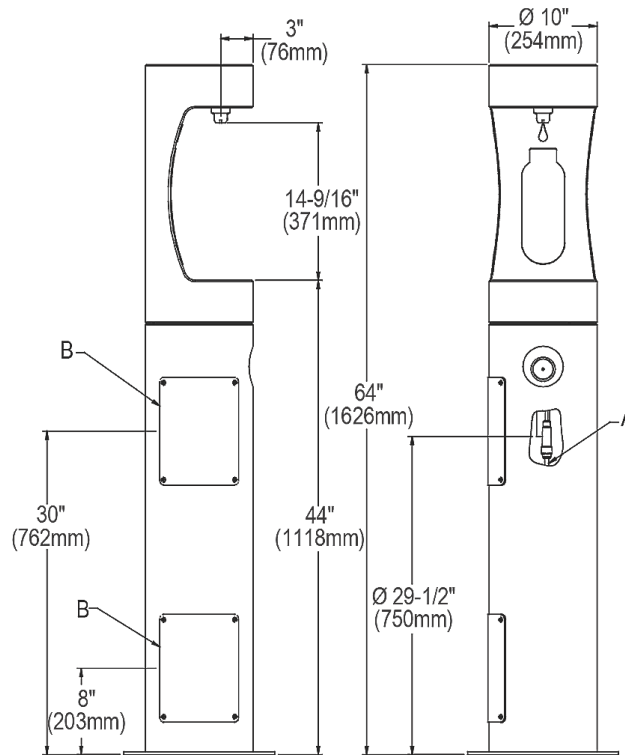

A = 3/8" O.D. Unplated copper tube connect. Shut off valve by others.  
B = Access panel(8" x 10")  
Note : New Installations Must Use Ground Fault Circuit Interrupter (GFCI).

*In keeping with our policy of continuing product improvement, Elkay reserves the right to change product specifications without notice. Please visit [elkay.com](http://elkay.com) for the most current version of Elkay product specification sheets. This specification describes an Elkay product with design, quality, and functional benefits to the user. When making a comparison of other producers' offerings, be certain these features are not overlooked.*