

INSTALLATION OF RING TYPE VAULTS

Figure 1. Typical Vault Installation

Vault configurations vary. Ring vaults are not acceptable in the Network area.

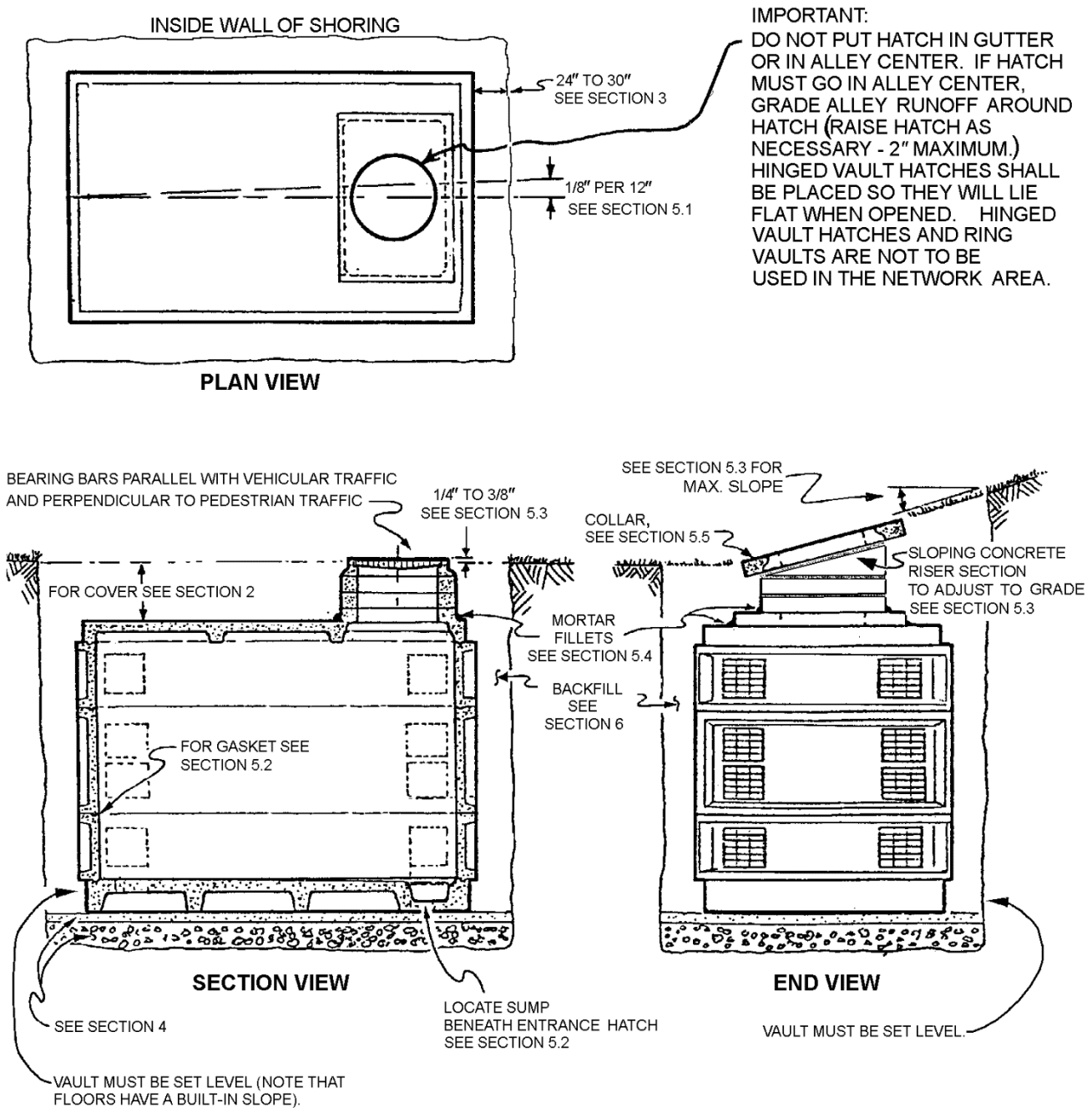

Standards Coordinator
Brett Hanson

Standards Supervisor
John Shipek

Unit Director
Andrew Strong

1. Codes

All work, including shoring and bracing, shall be in compliance with the latest editions of: State of Washington Department of Labor and Industries WAC 296-46B-450 "Equipment for General Use – Transformers and Transformer Vaults," Chapter 296-155 WAC "Safety Standards for Construction Work," Seattle Building Code Section 422 "Private and Utility Transformer Vaults," and the SDOT Director's Rule 2004—02, "Street and Sidewalk Pavement Opening and Restoration Rules."

2. Cover

The dimension from the vault top at the point of least depth to the pavement or ground above shall be as specified by Seattle City Light Work Order and/or construction drawings. Any deviation from this specification shall have the prior approval of the Seattle City Light Engineer.

All covers (other than vented grates) shall have a slip-resistant surface which has been approved by City Light Standards.

3. Excavation

3.1 Excavate so there is not less than 24 inches nor more than 30 inches between ends and sides of vault and the vertical sides of excavation or shoring unless larger excavation is authorized by the Engineer.

3.2 Remove shoring before backfilling.

3.3 If excavation bottom is saturated prior to placing bedding material, then over-excavate area as directed by the Engineer and place cobbles (3-inch to 8-inch stone – no broken concrete).

4. Bedding

The bedding material shall consist of 4 inches to 12 inches of stable base material, 1-1/4 inch minus gravel (Type 2).

If the excavation bottom is saturated or consists of inadequate bearing material, then over-excavate area as directed by the SCL engineer and place a construction geotextile at the bottom, then 12 to 24 inches of quarry spalls (Select backfill Type 17 or 27). See Figure 4.

If excavation bottom is not saturated and consists of adequate bearing material prior to placing bedding material, compact bottom of excavation with two full compacting operations at right angles to each other with a mechanical compactor.

Place a layer of crushed rock 1-1/4 inch minus gravel (Type 2), screed and compact to a minimum thickness of 4 inches and add 1/2 to 1-1/2 inches of sand (Type 6) to create a level surface.

Figure 4. Over-Excavation Detail

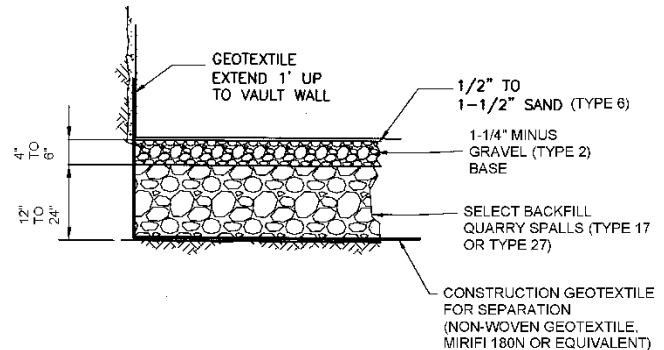

5. Installation

5.1 Setting Tolerances

5.1.1 Horizontal alignment: end to end $\pm 1/8$ in per 1-ft length of vault.

5.1.2 Vertical alignment

- Ring Vault 687 and larger with single-piece floor has a built-in sloped floor toward the sump; therefore, the bedding shall be level. Vertical slope tolerance: 3/8 inches per 10-ft length toward the sump.
- Multi piece ring vault floor does not have a built-in sloped floor; therefore, the bedding shall be even and slope toward the sump to ensure proper drainage. Vertical slope tolerance: 1/4 in $\pm 1/8$ inches in 10 ft toward the sump.

5.2 Vault Parts

- a. Do not install parts cracked or otherwise damaged so that watertightness may be impaired, or parts with reinforcing exposed.
- b. If a sump is specified by the SCL engineer, refer to Construction Guideline U2-12.1/NVH-60 for installation. Locate sump at same end as personnel hatch (see below, 5. 3.).
- c. For 814 and 818 vaults, place General Sealant G.S. No. 4 in joints between vault sections. For other vaults, place 5/8-inch by 1-inch butyl rubber "RUBATEX" gasket on the outer ridge of the interlocking joint.

5.3 Frame and Cover (Solid or Grate)

- a. *In streets, alleys, parking lots, and other vehicle areas*, to match slope of vault entrance with surrounding grade, the acceptable methods are:
 - Precast concrete sloping riser section
 - Cast-in-place concrete sloping riser section
- b. *In sidewalks and other non-vehicle areas*, to match slope of vault entrance with surrounding grade, the acceptable methods are:
 - Brick and mortar if the mortar is less than 1 inch thick
 - Precast concrete sloping riser section
 - Cast-in-place concrete sloping riser section

- c. Whenever the final grade of the hatch exceeds 10 percent (6 degree slope), the hinge side of the personnel hatch shall be located on the downhill side.
- d. Maximum slope of frame and grate shall not exceed 2 inches in 12 inches without permission of SCL engineer. Load break vaults shall not be installed if the grade exceeds 5.6 percent in any direction. This is to insure proper hot stick operation.
- e. Where the riser section is specified at 12 inches deep or more, order a length of Unistrut cast into the side wall of the riser.
- f. Set riser in 1 inch of mortar (1 part cement to 3 parts sand with polyvinyl acetate bonding agent).
- g. Adjust between 1/4-inch and 3/8-inch above grade to prevent water from entering vault, but not to cause a hazard. Ramp concrete to top of frame for gradual transition. Do not put hatch in gutter area. Put hatch 18 inches minimum away from curb line.

5.4 Seal Mortar

Place 2-inch, plus or minus, mortar fillets to seal out water at joints between vault top, cover slab, risers, and frame.

5.5 Concrete Collar

See SCL 0223.33.

5.6 Filling Spaces

Fill spaces between ground rods and floor slab and other spaces through walls, tops and slabs with dry pack mortar mixed with "Weldcrete" polyvinyl acetate bonding agent in accordance with the manufacturer's directions.

5.7 Ladder

Install a permanent ladder in the vault if the distance from the top of the cover to the vault floor exceeds 12 feet 6 inches. See Seattle City Light Drawing D-28304.

5.8 Conduit Entrances

SCL engineers shall specify the locations where the conduit enters the vault on the work order. Contractors/installers shall verify location before installation.

6. Backfill

Prior to backfilling, install all gaskets at top, bottom, and between walls and grout all seams and wall connections. Grout shall be non-shrink and reach 3000 psi minimum before backfilling.

Backfill with trench-type, controlled-density fill (CDF) that conforms to the City of Seattle Standard Specifications. Place backfill so that no voids are left under the reinforcing ribs or riser sections. The contractor/installer with the assistance of a Licensed Professional Engineer shall consult with the vault manufacturer to assure proper installation of the vault. Backfilling with some specified materials may require a multi-stage compaction processes to avoid damage to vault walls.

7. Vault Damage

Structurally damaged vaults shall be replaced or repaired. If the vault is to be repaired, then a Washington State licensed professional engineer shall certify that the vault meets the original structural design parameters. For this Standard, vaults with exposed rebar are considered to be damaged under any circumstances.

8. Grounding Electrode System

Install and test grounding electrodes per SCL 0461.10.

9. Sources

City of Seattle; "Standard Specifications for Road, Bridge, and Municipal Construction," 2011

Hanson, Brett; SCL Standards Engineer and subject matter expert for U2-15.1 (brett.hanson@seattle.gov)

Ng, Sharon; SCL Civil Engineer and subject matter expert for U2-15.1 (sharon.ng@seattle.gov)

SCL Construction Guideline NCB-20; "Grounding Network System Transformer Vaults, Wet, Dry, or Spot - Copper Bus"

SCL Construction Standard NCB-30; "Grounding Network System, Wet Vault, Non-Transformer, One or Two 48-Inch Bus Bars"

SCL Construction Guideline NDK-10; "Installation of Nonmetallic Conduit with FTB Concrete Encasement"

SCL Construction Standard U2-11; "Installation of Nonmetallic Conduit with Concrete, FTB Encasement"

SCL Construction Guideline U2-12.1/NVH-60; "Sump Pump Pipe Installation, Vaults and Manholes"

SCL Construction Guideline U9-7.3; "Grounding and Connection Diagram, Single Phase 26 kV Distribution Transformer"

SCL Construction Standard 0461.10; "Grounding Electrodes for Handholes and Vaults"

SCL Design Standard 9702.30; "Grounding and Bonding, Fundamentals and Detailed Requirements"

SCL Material Standard 7150.00; "Fluidized Thermal Backfill"

SCL Material Standard 7204.70; "Frames and Covers, 42-Inch Round, Iron"