

SEATTLE CITY LIGHT  
**CONSTRUCTION GUIDELINE**

STANDARD NUMBER: **NTP-41**  
 PAGE: 1 of 2  
 DATE: January 25, 2000  
 REV: NEW

**SEISMIC ANCHORING FOR OIL FILLED SPECIALTY TRANSFORMERS**

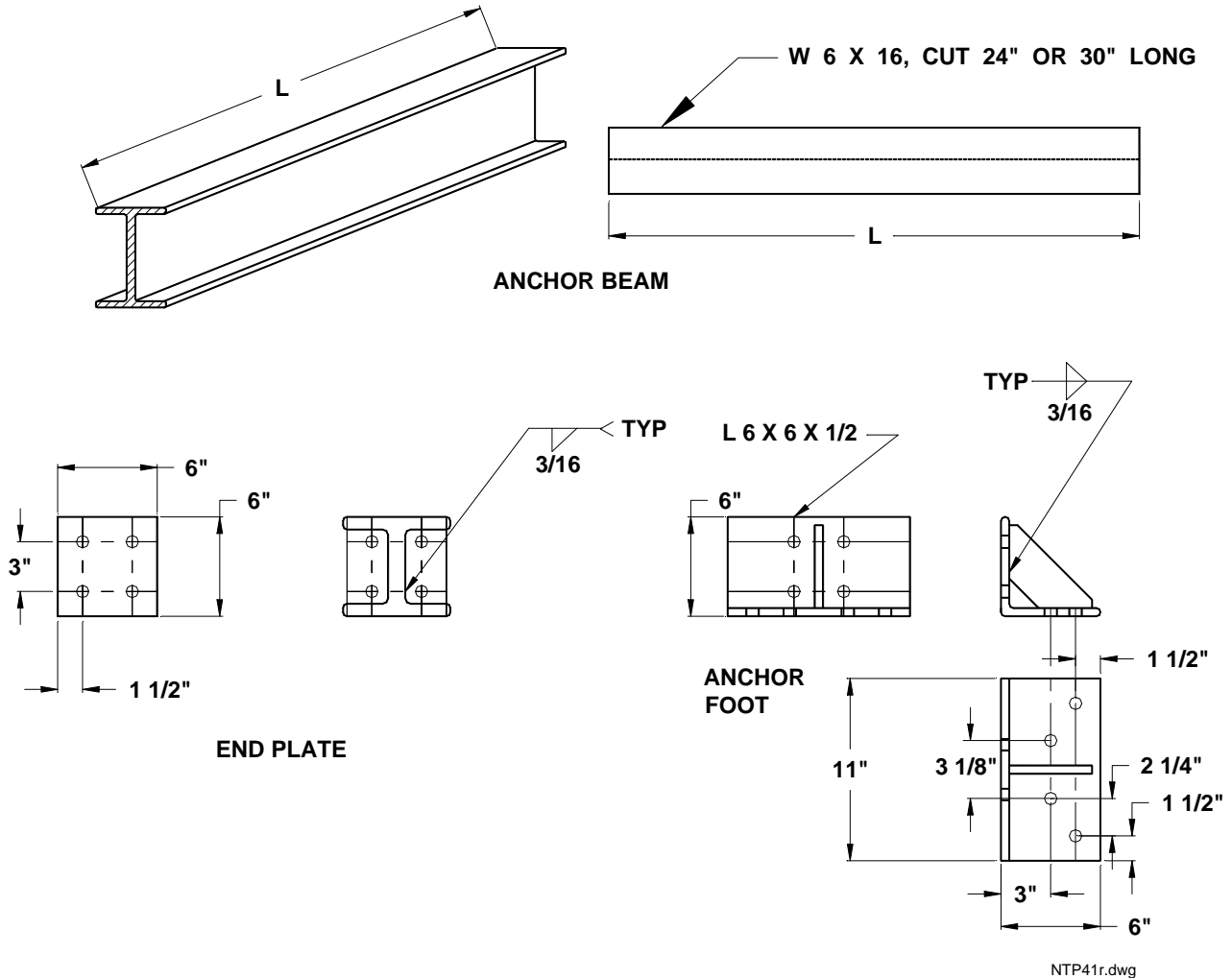

**NOTES:**

- Anchor Beam Sizing:** Cut W 6" x 16", A36 steel beams 24" long for circular transformers or 30" long for rectangular transformers.
- End Plate Fabrication:** Cut 1/2" A36 steel plate and drill 3/4" Ø holes using dimensions shown.
- Anchor Foot Fabrication:** Use L6" x 6" x 1/2" x 11" with 1/2" thick gusset, A36 steel. Drill holes in L6 to match end plate.
- Rail Assembly:** Weld end plate to end of beam. Paint with one coat of cold galvanizing spray. Bolt feet to end plate using four 1/2" Ø x 1-1/2" bolts.

ORIGINATOR	STANDARDS COORDINATOR	STANDARDS SUPERVISOR	UNIT DIRECTOR
<i>Thomas A. Lynch</i>	<i>Jim S. Horn</i>	<i>John C. Skinner</i>	<i>Betty Robini</i>

# CONSTRUCTION GUIDELINE

## SEISMIC ANCHORING FOR OIL FILLED SPECIALTY TRANSFORMERS

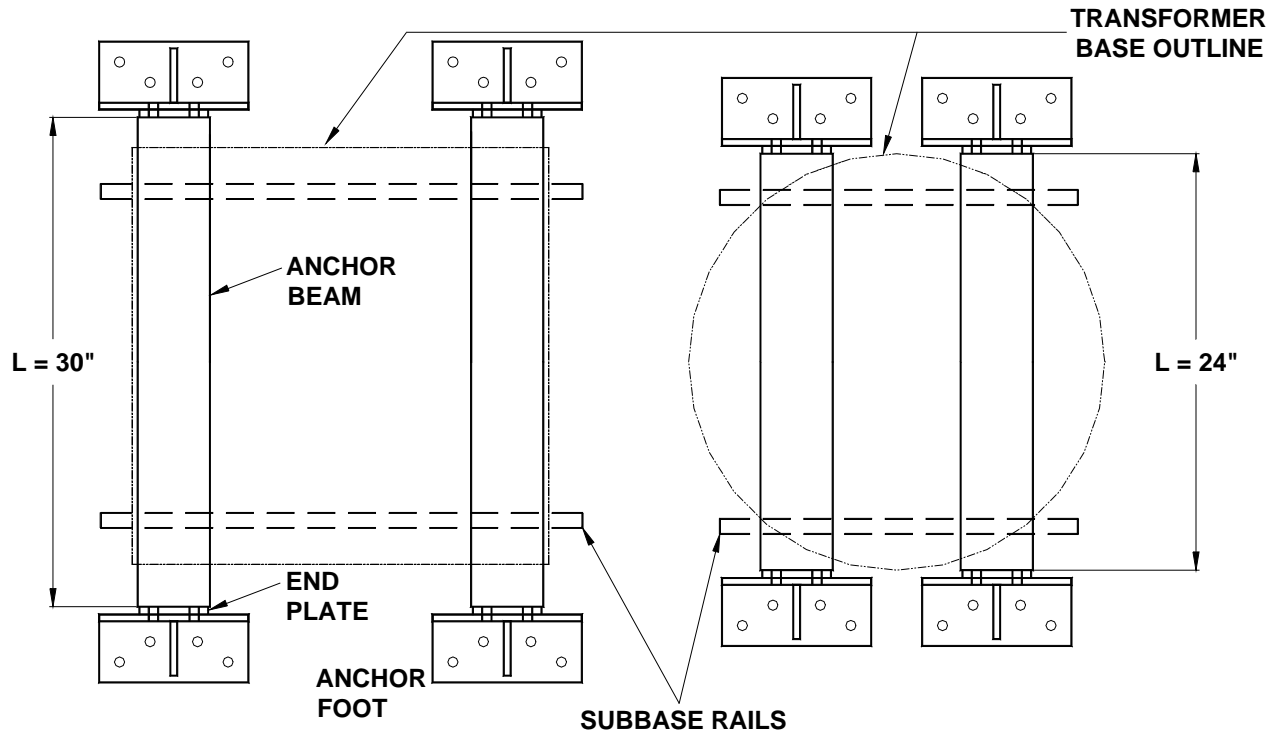

NTP41r.dwg

**NOTES:**

- Installation:** . Place transformer on beam as shown. Weld sub base rails to anchor rails, if necessary. Use 2" x 6" non-galvanized steel shims. Weld rail, shim and beam on outside edge.

When transformer is to be anchored, bolt feet to beams per note 4. Drill four 17/32" Ø x 4" holes in the floor per anchor foot. Anchor foot holes can be used as a template for drilling.

Secure anchor rails to floor with 1/2" Ø x 4" anchor bolts.