

TERMINATOR - 13 KV FOR INVERTED INSTALLATION

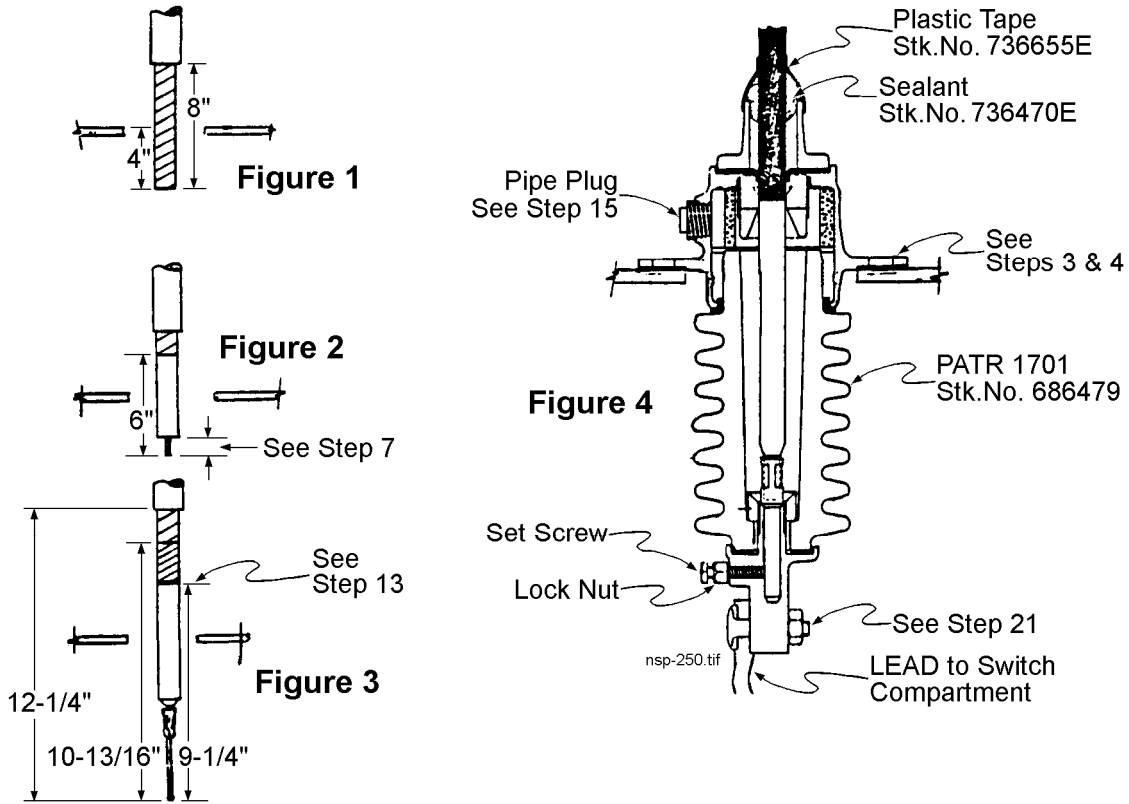

1. Drain oil from terminal chamber (if filled) and return it to South Service Center. Remove cover plate. Do not damage gasket.
2. Remove shipping covers from top of terminal chamber.
3. Scrape the paint off the top of the PATR flange where the mounting nuts (or cap screws) will be making contact to assure the terminator is properly grounded.
4. Mount the PATR's on the terminal chamber (using the gasket in the kit) and train the three-phase cable into its final position and trifurcate it. (See Construction Guideline NSP-110.) Leave a minimum of 36" of single conductor cables for termination. Each single conductor should extend a minimum of 4" below the top of the terminal chamber. Install the heat-shrink tubing from NSP-110 so that the bottom 9" of the cable is not covered.

ON EACH PHASE CONDUCTOR:

5. Note the phasing for final location and train the trifurcated cable alongside of the terminator and cut the cables 4" below the top of the terminal chamber. Refer to Figure 1.
6. Slide the compression ring, elastomeric boot, and ground clamp up the cable out of the way. Be sure they are in the right order.
7. Remove the shielding tape and semiconducting material for 6". Remove the insulation for 1-1/8" (for #2 to 4/0) or 1-1/4" (for 3/0 to 250 kcmil) and clean the conductor. Refer to Figure 2.

ORIGINATOR	STANDARDS COORDINATOR	STANDARDS SUPERVISOR	UNIT DIRECTOR
<i>Jim S. Horn</i>	<i>Charles L. Shaffer</i>	<i>John C. Chinner</i>	<i>Betty Robm</i>

8. Clean the connector, slide it onto the conductor and press. If more than one crimp is required, rotate the press 90 degrees to keep the connector straight.
9. File the rough edges of the connector smooth. Pencil insulation down to the connector barrel. Fill the indents and the space between the connector and the insulation with G&W 256 compound. Cover this with two layers of G&W 203 PVC tape to make a smooth surface.
10. Check the centering plug. If it will **not** slide over the heat-shrink jacket, throw it away. If it will, insert it into the top of the PATR. Be sure the lip fits properly against the diaphragm seal.
11. Neatly trim the heat-shrink jacket back 12-1/4" measured from the point of the connector. Do not damage the shielding tapes. Refer to Figure 3.
12. Remove the shielding tapes for 10-13/16" (measured as above) and solder the ends to prevent raveling (Figure 3). **Avoid excessive heat!**
13. Remove the semiconducting material for 9-1/4" (measured as above) and clean the insulation carefully using electrical insulation cleaner (Stock No. 726157E).

Note: If the semicon is a fabric tape, wrap two layers of G&W 203 PVC tape over the semicon, leaving 1/16" exposed. Start and end at the shielding tape. Do not cover the shielding tape. If the semicon is extruded, do not cover it with the PVC tape.

14. Remove the paint around the hole for the grounding strap and install the strap with a self-tapping screw and lock washer (in the kit). Bend the strap out of the way.
15. Remove the pipe plug and insert the plastic bottle. Do not loosen the set screw or lock nut on the cap.
16. Wearing plastic gloves, clean the cable and then apply a liberal coat of silicone grease (furnished with the terminator kit) from the connector to the heat-shrink tubing.
17. Insert the cable into the terminator with a steady force. Do not twist, rotate or reverse direction. The cable is in place when the shielding tapes are within 1/8" from the surface of the sealing plate.

Note: The excess special blue insulating compound is forced into the plastic bottle during this step. Do not remove it yet.

18. Loosen the bronze lock/sealing nut on the cap and tighten the set screw. Retighten the lock nut. Remove the plastic bottle and reinstall the pipe plug. Pull on the cable to be sure the set screw is properly seated.
19. Form the groundstrap around the cable shielding tapes. Cover it with the cushion material (in the kit) leaving a 1/8" gap. Slide the spring (or hose clamp) down over the cushion and tighten (if a clamp) to complete the ground connection.
20. Slide the boot and compression ring down and bolt the ring to the body.
21. Connect the lead to the switch compartment with the eye bolt connector. The connector is tin-plated and should not need to be sanded or wire-brushed. Tighten the bolt to 14 ft/lbs..
22. Seal the top opening around the cable with sealant (Stock Number 736470E) and wrap three layers of plastic tape over the cable and 1/4 of the way down on the terminator body. Refer to Figure 4.

CONTRACTOR'S NOTE: Do **not** proceed to Step 23 until phasing has been verified by Seattle City Light.

23. Reinstall cover plate and gasket. Do not use any gasket sealing compound. Torque the bolts and/or nuts equally, starting at the midpoints of the top, bottom, and sides.
24. Fill with 2 psig dry air or dry nitrogen and let stand for a minimum of 8 hours to test for leaks. If any leaks are detected, repeat Steps 23 and 24 as necessary.
25. Fill the chamber with new insulating oil (Material Standard 7531.0) to the bottom of the uppermost plug. Replace the plugs.