

**GROUNDING NETWORK SYSTEM DRY TRANSFORMER VAULTS,
 ALUMINUM BUS**

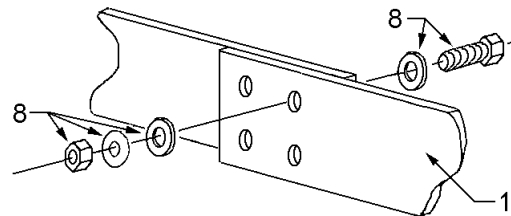
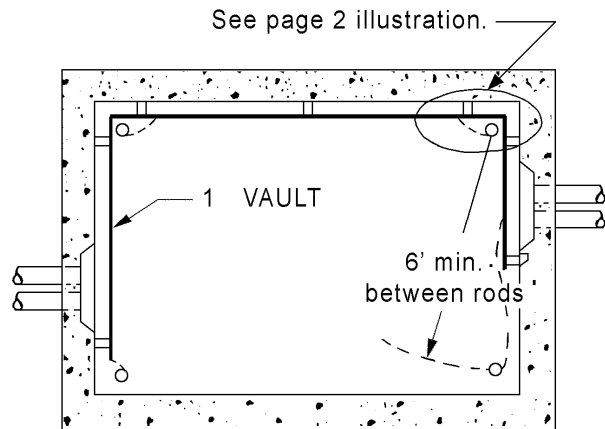
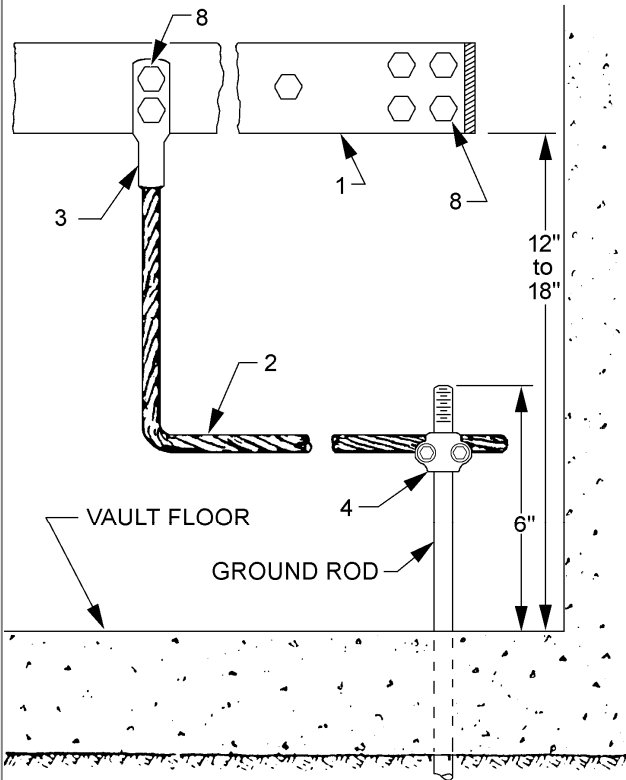

ALUMINUM BUS BAR CONNECTION

Item	Quantity	Description	Stock No.
1	As req'd.	BUS BAR 3/8" x 4" Al., Rectangular	630055
2	As req'd.	WIRE, 250 kcmil bare Cu., 1/C	610412
3	4	TERMINAL, Compression, 250 kcmil Al.	651265
4	4	CLAMP, Ground Rod, 5/8"-250 kcmil	676255
8	16	ASSEMBLY, Al. Bolt, Nut & Belleville Washer	782050

"Dry Transformer Vault" Definition: Dry vaults are above grade or are not subject to periodic flooding, such as locations in a customer basement. Dry vault equipment must be out of the rain or drip. Dry vaults may have vent gratings open to the rain.

Ground Rods: Four 5/8" x 8' ground rods shall be driven as shown before the vault floor is poured. When installing rods in vaults with limited overhead clearance, two 5/8" x 5' sectional rods, coupled, may be used in lieu of a 5/8" x 8' rod. The head of the rod shall protrude approximately 6" above the finished floor. A driving head shall be used to prevent damage to the ground rod threads.

Testing of Grounds: The total resistance of the ground rods shall not exceed 25 ohms. If this requirement is not met with four rods as shown, additional lengths shall be coupled and driven, or additional rods installed.

Ground Bus: Install an aluminum bus bar as shown along the wall of the transformer vault. Copper may also be used for dry vault ground buses; see Guideline NCB-20. The ground bus should extend under duct runs for neutral connection. See engineering drawings for particulars.

standards coordinator  Curtis Lu	standards manager  John Shipek	unit director  Pamela S. Johnson
---	---	---

CONSTRUCTION GUIDELINE

Grounding Network System Dry Transformer Vaults, Aluminum Bus

standard number: **NCB-10**

superseding: September 9, 2009

effective date: September 16, 2010

page: 2 of 2

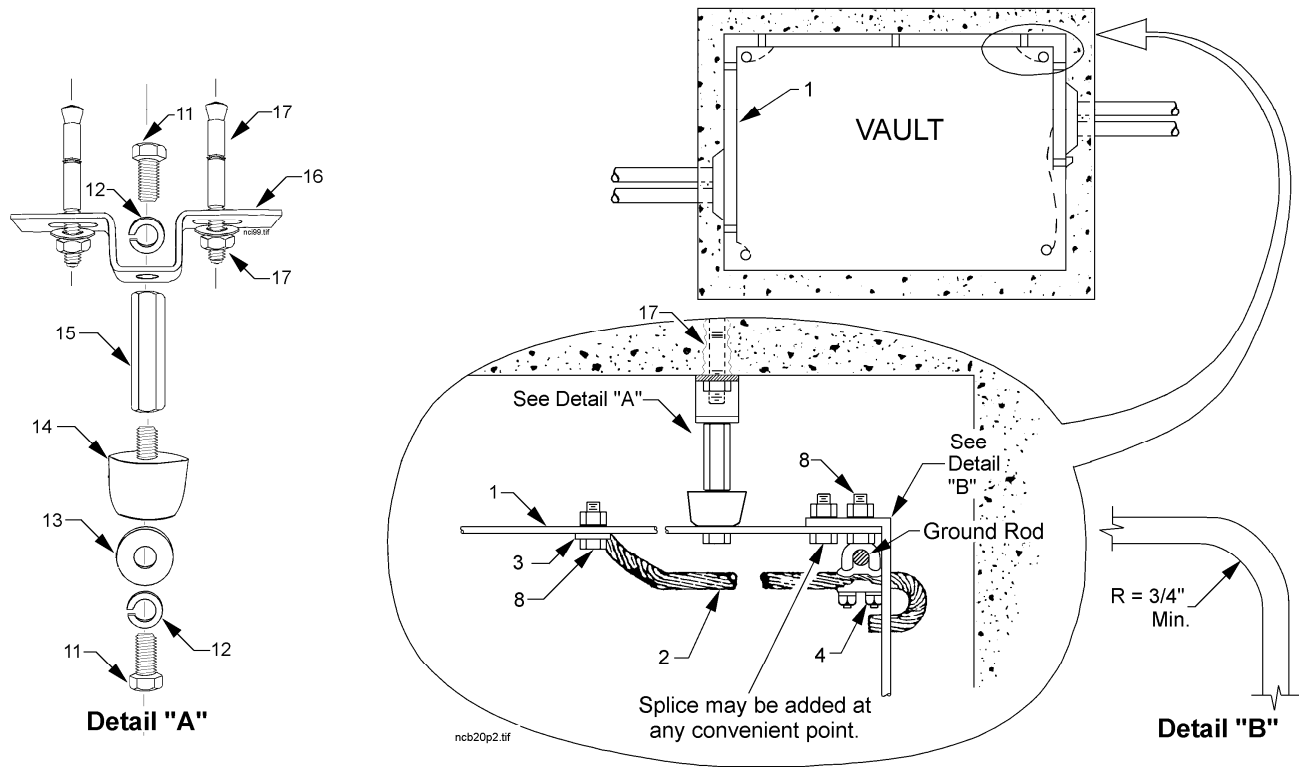

Item	Quantity	Description	Stock No.
1	As req'd.	BUS BAR 3/8" x 4" Al., Rectangular	630055
2	As req'd.	WIRE, 250 kcmil Bare Cu., 1/C	610412
3	4	TERMINAL, Compression, 250 kcmil Al.	651265
4	4	CLAMP, Ground Rod, 5/8"-250 kcmil	676255
8	16	ASSEMBLY, AL. Bolt, Nut & Belleville Washer	782050
11	2*	SCREW, cap, Hex Head, Cad Plated, 5/8" - 11 NC x 1"	784885E
12	2*	WASHER, 5/8" Lock, Galvanized	584260E
13	1*	WASHER, Flat, 5/8"	585030E
14	1*	INSULATOR, Dirigo Spool, Neutral	690880
15	1*	NUT, Coupling, Hex, Steel, 5/8" - 11 NC	780050E
16	1*	BASE, Neutral Bus Support	690882
17	2*	ANCHOR, SS, Light Duty, Stud Bolt (w/stud, nut, & washer) 1/2" x 2-3/4"	780032

* Quantity per insulator location.

Ground Wire: 250 kcmil bare stranded copper cable shall be used to connect ground rods to the ground bus. There should be sufficient slack in the cable to prevent damage due to tension or setting.

Vault Arrangement: See installation drawings for location details of Bus, Cable, Connections, Ground Rods, Ground Cables, and Customer Service Bus.

Bend Radius: Minimum bend radius for aluminum bus bar shall be 3/4".

Supports: Install supports, items 5, 6, and 7, approximately every 4 feet of wall mounted bus and around columns and corners as required. Use equal spacing on each straight section.

Transformer Neutral: The neutral terminal on the transformer may vary in location and orientation. Some transformers may have a neutral terminal with 4 bolt holes and others may have 2 bolt holes.

Electrical Connections: See Construction Guidelines NSV-30 and NSV-20 for contact surfaces and joint preparations.

Bus Tie Switches: Bus tie switches should have a case ground of 500 kcmil copper.

References: Construction Standards NSV-30 and NCB-80 for joint preparation details. Construction Standard NCB-40 for transformer vault bus installation.