

In-Building Transformer Vault Doors



1. Scope

This standard details the performance and hardware requirements for in-building vault doors.

2. Application

This standard applies to all new and retrofit doors for vaults in the Network and Looped Radial systems. This standard will be used by building owners and their contractors as well as Seattle City Light (SCL) engineers, crews, and inspectors.

3. Industry Standards

Vault doors shall meet the applicable requirements of the following industry standards:

ANSI/BHMA A156.3-2008; Exit Devices

ANSI/BHMA A156.4-2014; Door Control-Closers

NFPA 80; Standard for Fire Doors and Other Opening Protection

UL 10C; Standard for Positive Pressure Fire Tests of Door Assemblies

UL 1784; Air Leakage Tests of Door Assemblies

Standards Coordinator
Brett Hanson

Standards Supervisor
John Shippek

Unit Director
Darnell Cola

4. Definitions

Active leaf or active door – the door in a double-door assembly that is actively used. The active leaf contains the lock and door handle.

Astragal – a molding or strip whose purpose is to cover or close the gap between the edges of a pair of doors. The astragal can help prevent lock picking.

Construction core – a small format, interchangeable core for temporary use prior to vault acceptance when a permanent core will be installed.

Coordinator – a device used on a pair of doors to ensure that the inactive leaf is closed before the active leaf. A coordinator is necessary when an astragal is present on a set of double doors and an exit device is installed on the inactive door.

Dogged / dogging – manually securing the crash bar in the unlocked position from inside the room.

Inactive leaf or inactive door – the door in a double-door assembly that does not contain a lock, but is bolted when closed, and to which the strike is fastened to receive the latch or bolt of the active door.

Leaf – each of the two doors that make up a double-door assembly.

Storeroom function – door hardware is always in locked position and opening requires a key.

5. General Requirements

5.1 Doors and Frames

All doors shall be NFPA 80 Class A and have a 3-hour fire rating and be compatible with the installed hardware. In-building vault doors shall not have any vents or other types of openings. All doors shall be painted to prevent corrosion.

All single doors shall swing out 120 degrees from the vault opening. All double doors shall swing out 180 degrees from the vault opening. Door swing shall be protected by bollards if vehicles or mobile equipment could enter the door swing area.

In an existing vault where new hardware is being installed in a reused door, cover unused holes with material that maintains the fire rating and security requirements outlined in this standard and satisfies the requirements of the Authority Having Jurisdiction (AHJ).

Head and jamb frame throats shall be treated with a bituminous coating. Frame cavity shall be filled with grout.

5.2 Door Hardware

5.2.1. Hinges

Hinges shall be extra heavy-weight steel or stainless steel with bearings and non-removable pins. Furnish and install a minimum of one hinge for every thirty inches of door height.

Hinges shall be one of the following products or an equal approved by SCL prior to construction:

- McKinney T4A3786 4-1/2 x 4-1/2 NRP US26D (steel for interior conditioned spaces)
- McKinney T4A3386 4-1/2 x 4-1/2 NRP US32D (stainless steel for exterior and unconditioned spaces)

5.2.2. Locks

Locks shall be ANSI A156.3-Grade 1, fire-rated exit devices.

Mortise-type locks shall be used for single doors.

Mortise-type locks shall be used for the active leaves of door pairs. Surface vertical rod-type locks shall be used for the inactive leaves of door pairs.

Double-door assembly shall include overlapping astragals, coordinators, and carry bars.

For 7-ft high doors, there shall be one guide for the bottom rod and one guide for top rods. For doors over 7 ft high, there shall be one guide for the bottom rod and two guides for top rods.

The pull side trim shall be a pull type. On pairs, only the active leaves shall have pull trim. Doors shall be equipped with panic bars that are normally latched but open under simple pressure, never binding.

For larger doors, supply Grade 1 fire-rated exit devices that are listed for use with those door dimensions. Confirm manufacturer and product numbers prior to ordering.

Locks shall be one of the following products or an equal Grade 1 lock approved by SCL prior to construction:

Single doors

- Sargent 12-8904 (x MAL or 824 pulls) 72-41 US32D (storeroom function locks with anti-pick function). Single door locks shall be kept locked at all times.

Door pairs

- Sargent 12-8904 72-41 US32D (x MAL or VRT26 Rockwood pulls cut short on edge for fit with astragal) for active leaves (storeroom function locks with anti-pick function). Door pair locks shall be kept locked at all times.
- Sargent 12-8710 (exit only, no pulls) US32D. This lock shall be used for inactive leaves.

Construction cores shall be furnished and installed by the building owner prior to vault acceptance. The owner shall provide adequate keys (two minimum) for the construction phase.

Permanent cores, SFIC 7-Pin Best type, will be supplied and installed by SCL.

5.2.3. Door Closers

Door closers shall be ANSI A156.4-Grade 1, parallel arm application with heavy duty rigid arms.

Door closers shall be one of the following products or an equal approved by SCL prior to construction:

- Norton PR7500 689
- Sargent 351-P10 EN (25-year warranty)

5.2.4. Astragals

Overlapping astragals are required on the active leaf of pairs.

Astragals shall be Pemko 357SP or an equal approved by SCL prior to construction. See Figure 5.2.4.

Figure 5.2.4. Astragal

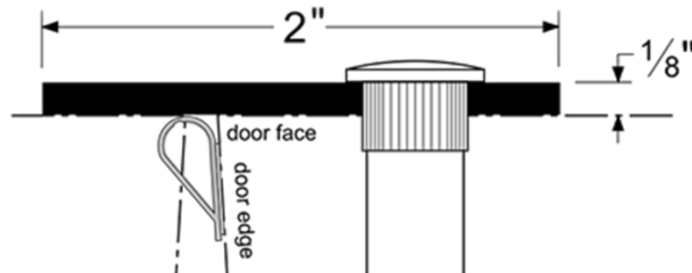

5.2.5. Coordinators

Door coordinators shall be installed for all door pairs. Soffit plates shall be attached. Soffit plates shall be Rockwood 2601 AB or C soffit plate brackets or an equal approved by SCL prior to construction. See Figure 5.2.5.

Figure 5.2.5. Door Coordinator

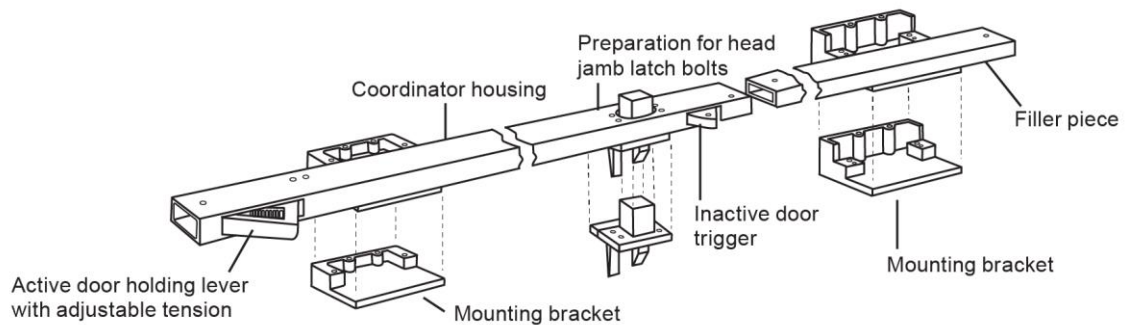

Coordinators shall be one of the following products or an equal approved by SCL prior to construction:

- Rockwood 2600 Series with wear plates on door faces
- Rockwood 2672 for doors with a 72-in opening width

5.2.6. Carry Bars

Carry bars shall be installed for all door pairs. Carry bars shall be Rockwood 1100 or an equal approved by SCL prior to construction. See Figure 5.2.6.

Figure 5.2.6. Carry Bar



5.2.7. Wall Stops

Wall stops shall be installed where necessary to cushion the contact between trim and the wall. Wall stops are not required for doors without pull side trim. For example, wall stops are not required for the door leaf of a pair that does not have trim. Wall stops shall be Rockwood 400 US26D or an equal approved by SCL prior to construction.

5.2.8. Gasketing

Gasketing shall be provided including self-adhesive backing on frame stops and the edge of active leaves of pairs. Gasketing shall be fire rated in accordance with UL 10C and smoke tested in accordance with UL 1784. Gasketing shall be Pemko S88D or an equal approved by SCL prior to construction.

6. Testing and Acceptance

6.1 Single Door Testing

The following functionality will be tested and confirmed by SCL prior to vault acceptance:

- Small format interchangeable cylinder, 7-pin is installed
- Lockset installed is Storeroom Function and always in the locked position
- Crash bar allows free egress and is never binding
- Door closer pulls the door to latch every time from every position
- Anti-pick function of the lock works
- Panic hardware dogging function is not installed
- Daylight is not visible around the door when the door is closed from the inside of the room

6.2 Double Door Testing

The following functionality will be tested and confirmed by SCL prior to vault acceptance:

- Small format interchangeable cylinder, 7-pin, is installed
 - Lockset installed is Storeroom Function and always in the locked position
 - Crash bar allows free egress and is never binding
 - Door closer pulls the door to latch every time from every position
 - Anti-pick function of the lock works
 - Panic hardware dogging is not installed
 - Daylight is not visible around the door when the door is closed from the inside of the room
 - Vertical rods are adjusted properly so that they:
 - Drop deep enough to catch and hold.
 - Retract high enough for a smooth, safe exit.
 - Door coordinator functions regardless of which door is used to exit, and the carry bar is installed properly
 - Astragal does not prevent exiting from fixed leaf
-

7. References

SCL Construction Standard 0751.00; "Customer Requirements, In-Building Transformer Vaults, Network and Looped Radial System"

8. Sources

Hanson, Brett; SCL Standards Engineer, subject matter expert, and originator of 0751.49 (brett.hanson@seattle.gov)