

**Customer Requirements, In-Building Transformer Vaults,  
Network and Looped Radial Systems**



**1. Table of Contents**

1. Table of Contents.....	1
2. Scope .....	2
3. Application.....	2
4. Conflict .....	2
5. Accessibility .....	3
6. Location .....	4
7. Construction (Walls, Roof, and Floors).....	6
8. Doorways and Openings .....	7
9. Ventilation .....	8
10. Drainage .....	10
11. Pipes and Ducts .....	11
12. Storage in Vaults .....	11
13. Sprinkler Systems .....	11
14. Heat Sensors.....	11
15. References .....	11
16. Sources .....	11

Standards Coordinator  
Brett Hanson

Standards Supervisor  
John Shipek

Unit Director  
Andrew Strong

## 2. Scope

This standard provides the requirements for Seattle City Light (SCL) Network and Looped Radial (formerly URD) transformer, in-building vaults. These vault rooms contain SCL owned or maintained equipment.

Network-ready vaults shall meet Network vault requirements.

An in-building transformer vault is a special room inside a building in which oil-filled transformers and related electric power distribution equipment are housed.

Concurrent vault requirements are listed in SCL 0751.60. Topics include vault grounding, lighting, ducts, cables, bus ducts, etc. SCL 0751.60 also lists required customer submittals and SCL provided project-specific requirements.

Electrical vaults within buildings that contain equipment owned and maintained by others are not covered by this standard.

---

## 3. Application

An in-building vault is required if the customer's electrical load exceeds the limits listed in Requirements for Electrical Service Connection, Table 5-1 and the customer cannot provide exterior space for the installation of SCL transformers and associated equipment on the project premises.

Vault requirements unique to either Network or Looped Radial (URD) systems are clearly indicated. All other requirements are applicable for both Network and Looped Radial systems.

This standard is intended for use by customers and SCL engineering, customer service, inspecting, reviewing, and operations personnel

---

## 4. Conflict

Where conflict exists between SCL requirements, the following order of precedence shall apply:

1. Project specific Customer Requirements Package, including the Service Construction Letter and Drawing
2. SCL 0751.00
3. Seattle Building Code, 2006, Section 422 (within the City of Seattle)
4. SCL 0751.60
5. Other SCL construction guidelines or construction standards
6. Other industry standards

## 5. Accessibility

- 5.1 Seattle City Light prefers that SCL trucks be able to access the door or hatch of the in-building vault. Looped Radial equipment hatches shall be outside of the in-building vault.
- 5.2 In-building vaults shall be located no more than one floor below the building's exterior finished grade.
- For a Network or Network-ready vault located such that it is not readily accessible for the oil servicing hose and the 12-foot-tall oil pump van, a 6-inch diameter oil hose access to the in-building transformer vault shall be installed for use by SCL crews. The oil hose access shall be routed exterior to the in-building vault and provide a maximum hose length distance of 75 feet from the vault to an area accessible to the oil truck. The openings shall be located near the equipment access and the customer is responsible for grouting and waterproofing around the opening. Location shall be coordinated with SCL prior to construction.
- 5.3 Network: One or more door(s) or ceiling hatch shall be provided for every in-building vault.
- 5.4 Looped Radial (formerly referred to as URD): One or more door(s) shall be provided for every in-building vault.
- 5.5 The opening shall be adequate in size to permit the installation and removal of the equipment located in the vault.
- 5.6 The door access shall be kept unobstructed at all times.
- 5.7 An unobstructed level area shall be provided at the entrance to the in-building vault.
- 5.8 The level area shall be large enough for moving SCL equipment into and out of the in-building vault.
- 5.9 All in-building vaults shall be readily accessible to SCL personnel at all times.
- 5.10 If it is necessary to pass through locked doors to reach the in-building vault, keys for those locked doors shall be kept in a readily accessible key box near the first locked door. A spare set shall also be provided.
- 5.11 Non-SCL personnel shall not enter the in-building vault without SCL personnel after the vault has been accepted by SCL.
- 5.12 There shall be a permanent, clear equipment access path between the vault and the building exterior or right-of-way.
- 5.12.1. Sufficient horizontal and vertical clearance shall be provided for electrical equipment and machinery to move the equipment without interrupting other energized equipment. See SCL 0751.77.
- 5.12.2. The path floor shall be smooth, without seams or ridges or pads.
- 5.12.3. Customer shall move transformers to in-building vault. See Section 5.13.
- 5.12.4. The path floor shall be designed to support the weight of the electrical equipment and machinery to move the equipment. Transformers can weigh up to 30,000 pounds and have dimensions up to 12 feet long by 8 feet wide by 9 feet tall.
- 5.13 Equipment transportation agreement is required for in-building vaults. An equipment transportation agreement makes the property owner responsible for moving equipment between the right-of-way and the in-building vault.
- The property owner shall sign a legally binding Equipment Transportation Agreement that will be attached to the property title. The Agreement requires the building owner to move

transformers into and out of the building, to and from the transformer vault, to a mutually agreed upon location on, or in the vicinity of, the owner's property from which SCL is able to deliver or pick up the transformers using normal transporting methods and equipment. Any damage that occurs to the transformers during transportation by the building owner and any additional expense incurred as a result of damage shall be paid by the building owner. A copy of the agreement shall be included in the vault document enclosure, see 0751.60 Section 14. Install Equipment Transportation Agreement sign, see SCL 7651.25.

## 6. Location

- 6.1 In-building vaults shall be located such that they can be ventilated to the outside without using ducts, if practical.
- 6.2 In-building vaults shall be dry and not subject to running, standing, flooding, or infiltration of water.
- 6.3 Exact location of in-building vault shall be determined for each specific project.
- 6.4 If the in-building transformer vault is located below grade level, an above-grade pulling vault is required to help prevent water intrusion.
- Above-grade pulling vault shall be accessible. See Section 5 Accessibility.
- Vault shall be a minimum of 5 feet deep by 7 feet wide by 8 feet tall. If the vault is used to connect to a high-voltage switch in the building or contains multiple feeders, additional space shall be required. Confirm dimensions with City Light engineer.
- Vault walls shall be concrete or concrete filled CMU. See Section 7 Construction.
- Vault door shall be 42 inches wide by 80 inches tall per SCL Standard 0751.49. The door shall be able to swing open 120 degrees.
- Install a UV-resistant sign on the exterior side of the door, stating "DO NOT BLOCK DOOR". Sign shall be a red phenolic resin sheet 6 mils thick with white one inch tall lettering.
- Install pulling irons opposite to, and centered on, the incoming conduits per SCL NCI-62. See Section 4 of SCL NCI-62 for ceiling design requirements.
- Primary conduits shall enter the vault through the floor and shall extend 10 inches above the floor.
- A two-inch conduit shall be routed from the vault to the in-building transformer vault for utility equipment grounding. Conduit bends shall be rigid galvanized steel.
- Conduits penetrating the floor shall be rigid galvanized steel and encased in a house-keeping pad with end bells flush with the top of the pad. See Figure 6.4 below. End bells shall meet SCL 7055.09. Encasement shall not protrude into the door passageway.

**Figure 6.4 Above-Grade Pulling Vault**

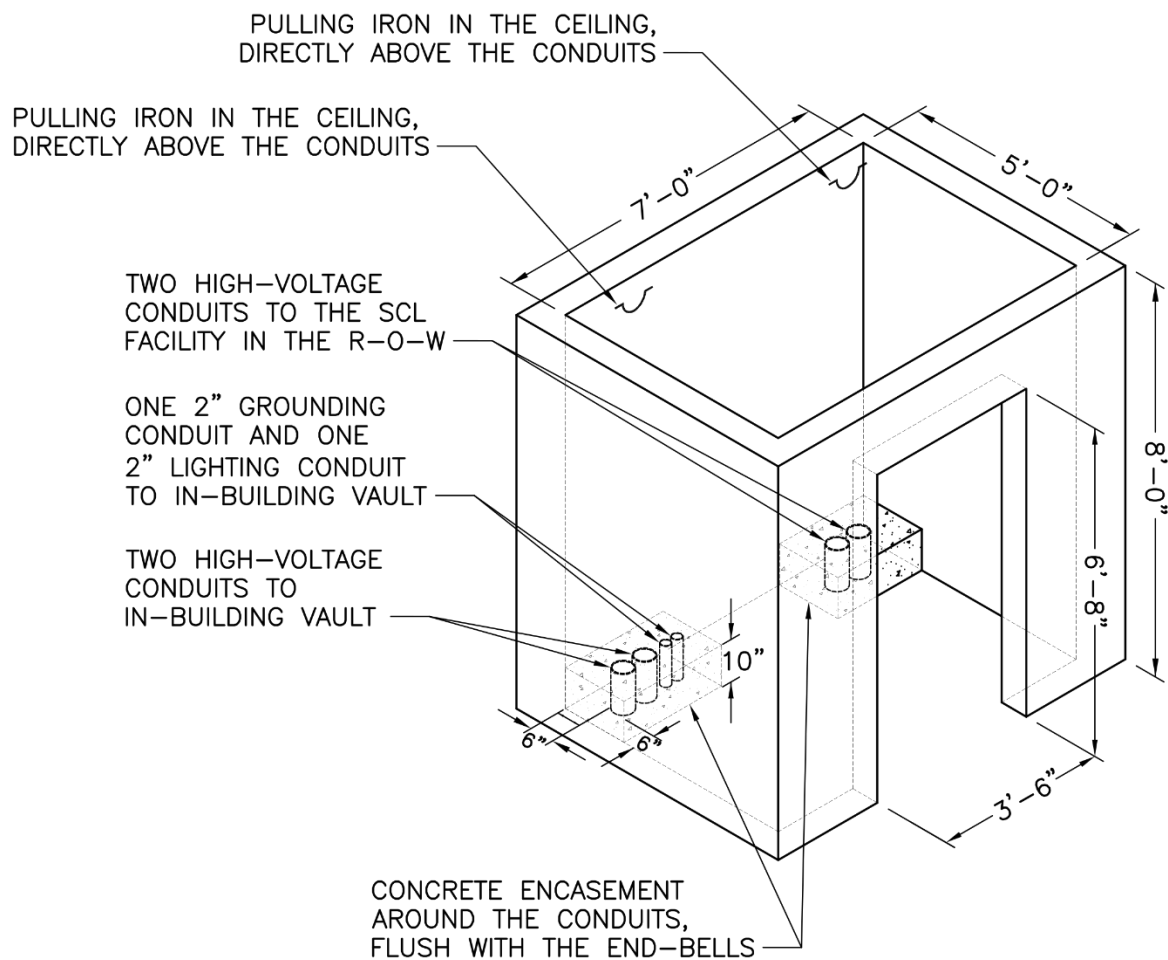

## 7. Construction (Walls, Roofs, and Floors)

- 7.1 Floors, walls, and ceilings of in-building vaults shall have a minimum three-hour fire resistance rating.
- 7.2 All penetrations shall be sealed to be three-hour fire rated.
- 7.3 Network: The bottom 8 ft of wall, minimum, shall be solid concrete at least 6 in thick. Above the solid concrete wall, it may be solid concrete or concrete filled masonry units at least 6 in thick.
- 7.4 Floors and ceilings of in-building vaults shall be constructed of solid concrete at least 6 in thick.
- 7.5 Looped Radial (URD): Walls of in-building vaults shall be constructed of solid concrete or concrete-filled masonry units at least 6 in thick.
- 7.6 Network: Seismic anchors shall be embedded in the floor. See U10-5.3/NTP-40.
- 7.7 Steel support channels shall be embedded in the ceiling for ceiling-supported cable hangers per SCL 0257.06. For Looped Radial vaults, channel layout shall be parallel to the wall that the customer's service enters. For Network vaults, channel layout shall be determined by SCL for each specific project.
- 7.8 Pre-tensioned or post-tensioned concrete shall have the cable locations permanently marked with red epoxy paint on the surface of the concrete over the encased tendons.
- 7.9 In-building vault dimensions shall depend on the equipment and working clearances required. See SCL 0751.77.
- 7.10 The maximum ceiling height is 18 feet.
- 7.11 For working space for all equipment 600 V and under, see SCL 0751.77.
- 7.12 The vault floor shall be smooth, without seams, ridges, or pads. The floor shall slope toward the sump 1/2 inch for every 10 feet. Topping slabs and skim coats are prohibited.
- 7.13 Pulling Irons
- 7.13.1. Pulling iron(s) shall be installed per SCL NCI-62 opposite and centered on the primary cable duct bank entrance(s). Additional pulling irons may be required.
- 7.13.2. Pulling irons shall have an ultimate (breaking) strength of 10,000 lb.
- 7.13.3. Pulling irons shall provide a minimum 3-in diameter round gap for hook or shackle attachment.
- 7.13.4. For Looped Radial vaults with a six foot or wider equipment access doorway, provide an additional pulling iron. Pulling iron shall be located opposite and centered on the doorway and meet SCL NCI-62.

## 8. Doorways and Openings

### 8.1 Doorways

- 8.1.1. Looped Radial (URD): SCL requires an equipment access door. If equipment access is provided by a drop-in hatch outside the vault, a separate personnel door that permits egress through the building is required. The number of personnel access doors shall be determined for each specific project by SCL.
- 8.1.2. Network: SCL requires two doors for personnel egress; one of which may also be the equipment access door.
- 8.1.3. Personnel access doorways shall be at least 3 ft 6 in wide and 6 ft 8 in high.

### 8.2 Doors, Frames, and Door Hardware

- 8.2.1. For all door, frame, and door hardware requirements, see SCL 0751.49.

### 8.3 Sills

- 8.3.1. All in-building vault doorways shall have a removable oil containment sill of 6 in (minimum).
- 8.3.2. The sill shall be made of 6-in angle iron and painted safety yellow. The sill shall extend past door frame 6 inches.

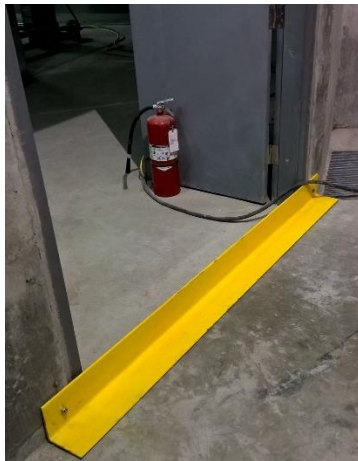

- 8.3.3. The sill shall be installed behind each door and be connected to the wall with flush mount internal-threaded anchors. See SCL 7801.10.
- 8.3.4. The sill shall be installed after the installation of the electrical equipment and prior to energization.
- 8.3.5. The sill shall be sealed to the floor and wall with oil-resistant caulk.

### 8.4 Equipment Installation, Access, and Removal

- 8.4.1. Equipment access doorways shall be sized to accommodate the installation and removal of electrical equipment (including the installation machinery).
  - 8.4.1.1. If vault contains single phase transformers only, the doorway shall be at least 3 ft 6 in wide and 6 ft 8 in high.
  - 8.4.1.2. All other doorways shall be sized by SCL, as needed.

## 9. Ventilation

- 9.1 Ventilation systems shall be provided to dispose of heat from transformer total losses without creating a temperature rise that exceeds the transformer rating.
- 9.2 The owner is responsible for maintaining the vault ventilation system to ensure proper and continued operation.
- 9.3 Method of ventilation
  - 9.3.1. Utility in-building vaults shall be mechanically ventilated.
  - 9.3.2. Positive or negative pressure ventilation systems shall supply air for in-building vaults.
  - 9.3.3. Ventilation system shall supply a minimum of 1.6 cfm of air per kVA of transformer capacity.
- 9.4 Location
  - 9.4.1. Exhaust ventilation openings and duct terminations shall be located a minimum of 9 ft above adjoining grade and finished walking surfaces. Exhaust openings and duct terminations shall be located a minimum of 10 feet from fire escapes, means of egress, combustible materials, any doors (except SCL doors), windows, or openings, and property lines. Confirm additional exhaust clearances with the Authority Having Jurisdiction.
  - 9.4.2. Exhaust outlets shall be located on the exterior of the building.
- 9.5 Arrangement (of ventilation equipment)
  - 9.5.1. Fans and thermostats
    - 9.5.1.1. The in-building vault ventilation fans shall be installed outside of the vault.
    - 9.5.1.2. The in-building vault ventilation fans shall be controlled by thermostats located inside the vault.
    - 9.5.1.3. Remote temperature controller shall be installed.
    - 9.5.1.4. A dedicated thermostat will activate the fans at 70 degrees F.
    - 9.5.1.5. The second dedicated thermostat will turn off the fans at 140 degrees F.
    - 9.5.1.6. Thermostats shall be analog (dial) type (Honeywell T631A-C type Farm-O-Stat, Model No. T631A1022). Locate thermostats on an interior wall within 3 ft of an entry door, 5 ft above finished floor, and in dead air space. Confirm final location with SCL prior to rough-in.
    - 9.5.1.7. Looped Radial (URD)/Network-Ready: Install a combination visible/audible alarm (Edwards Signal 868STRR-N5) and connect it to a dedicated circuit. Install a sign outside of the vault below the alarm that reads "If alarm operates, call Seattle City Light at 206-625-4448." If the ventilation system becomes inoperable or does not turn on at 70°F, or if the vault temperature exceeds 140°F, the visible alarm shall be configured to activate. Confirm with the inspector whether the audible alarm function is required.
    - 9.5.1.8. Network: No visible or audible customer installed alarm required. SCL installs monitoring equipment.
    - 9.5.1.9. The building owner is responsible for providing power and maintaining the vault ventilation system, including the fans.
    - 9.5.1.10. Looped Radial (URD): The building owner may monitor vault fan alarm signal, but shall not control vault fan or alarm.



9.5.2. Vents

- 9.5.2.1. Intake air shall be drawn from an exterior air source such as the building exterior or garage. It shall not be drawn from conditioned air in the building.
- 9.5.2.2. Intake vents shall be located at least 18 in above the exterior floors.
- 9.5.2.3. The intake vents shall be located in the lower third of the interior walls of the vault. The bottom of the vent shall be located 18–24 inches above the finished vault floor.
- 9.5.2.4. The exhaust vents shall be as near to the ceiling as possible (in the upper third of the wall) or in the roof or ceiling of the vault.
- 9.5.2.5. Exhaust shall vent directly to the outside of the building or shall be ducted, using three-hour rated material.
- 9.5.2.6. Exhaust cannot vent to a covered parking area or garage.
- 9.5.3. The ventilation system shall cause air to flow across the cooling fins of the transformers. For each transformer rated 500 kVA and above, provide an intake vent mounted low behind the transformer
- 9.5.4. Ventilation system shall direct airflow uniformly across the vault.
- 9.5.5. The vault ventilation system shall be controlled independently of the building ventilation system.
- 9.5.6. No ducting shall be installed within the vault.
- 9.5.7. Vents shall not allow water to enter the vault.
- 9.5.8. Exhaust vents shall be 3 ft away from non-combustible surfaces and 10 ft away from combustible surfaces.

9.6 Ventilation Covering

- 9.6.1. Interior of vault face ventilation openings shall be covered with a 0.12-in diameter minimum metal gratings with 1/2-in maximum mesh openings to prevent rodent intrusion. Gratings shall be McNichols Wire Mesh 3658220041 or 3658220048 or equal with approval prior to rough-in. Grating shall be flush with wall.



- 9.6.2. Exterior of vault face ventilation openings shall be covered with fixed inverted V-shaped louvers that eliminate visual see-through and prevent rain from entering the vault. Louvers and frames shall be fabricated of 3/16-in thick (minimum) galvanized angle iron or equal with approval prior to rough-in. Louvers shall be supported and anchored to prevent unauthorized access to the vault. Any carriage bolts used shall be secured from within the vault.



- 9.7 Dampers
- 9.7.1. Intake vents in the vault walls shall have automatic closing fire dampers rated for three-hour fire resistance.
- 9.7.2. Damper actuating device shall function at 165°F. Any electrical dampers shall remain open for passive ventilation under normal conditions.
- 9.8 Ducts
- 9.8.1. If used, exhaust ducts shall have a three-hour fire resistance rating.
- 9.8.2. Exhaust ducts shall extend from the vault to the outside of the building.
- 9.8.3. Exhaust ducts shall be used exclusively for vault ventilation.
- 9.8.4. No fire dampers shall be installed in exhaust ducts.

---

## 10. Drainage

- 10.1 Drains are prohibited in all in-building vaults.
- 10.2 Sumps
- 10.2.1. All in-building vaults shall have a dry sump.
- 10.2.2. Network and Network-Ready: The sump shall have a minimum capacity of 8 cubic ft.
- 10.2.3. Looped Radial (URD): The sump shall have a minimum capacity of 2.25 cubic ft.
- 10.2.4. Sumps shall have an opening with 18 in minimum in both length and width and have a depth of at least 12 in.
- 10.2.5. Sumps shall be equipped with a removable galvanized steel grate that is flush with the floor and capable of supporting 400 lb.
- 10.2.6. Sumps shall have a grouted bottom.
- 10.2.7. At least one sump shall be located near the personnel door but not in the equipment access path or in front of the door.
- 10.2.8. The floor shall slope at least 1/2 inch in ten ft towards the sump.

## 11. Pipes and Ducts (Water Pipes and Accessories)

- 11.1 No pipes or foreign ducts shall pass or enter the in-building vault.
- 11.2 Electrical conduits terminating in the vault shall be sealed with a listed three-hour fire rated material.
- 

## 12. Storage in Vaults

- 12.1 No material shall be stored in any in-building vault.
- 

## 13. Sprinkler Systems

- 13.1 Sprinkler systems shall not be installed within an in-building vault.
- 13.2 In-building vaults shall be maintained in a dry condition.
- 

## 14. Heat Sensors

- 14.1 If used, heat sensors shall be located near the door, away from electrical penetrations and equipment. All conduit and associated boxes shall be embedded in the concrete structure. Confirm locations with the inspector prior to rough-in.
- 14.2 The sensor shall be able to be tested from outside the vault without an SCL standby.
- 

## 15. References

- SCL Construction Standard 0257.06**; "Ceiling Channel for In-Building Vaults"
- SCL Construction Standard 0751.49**; "In-Building Transformer Vault Doors"
- SCL Construction Standard 0751.60**; "Concurrent Customer Requirements for In-Building Transformer Vaults"
- NFPA 70 - NEC**; National Electrical Code; 2008
- Requirements for Electric Service Connection (RESC)**; Seattle City Light, 2007
- Seattle Building Code**; Section 422; 2006
- 

## 16. Sources

- Hanson, Brett**; SCL Standards Engineer and subject matter expert for 0751.00 (brett.hanson@seattle.gov)
- Edwards, Tommy**; SCL Electrical Reviewer and subject matter expert for 0751.00 (tommy.edwards@seattle.gov)
- SCL 2007-2008 In-Building Vault Subcommittee**: Shayan Arya, Ed Chu, Toni Gamble, Laurie Hammack, Bob Hansen, Gerard Legall, Eivind Perander, Uzma Siddiqi, Quang Ta, and Roger Tapp
- SCL Construction Guideline U2-8** (canceled); "In-Building Transformer Vaults (Non-Network Area)"
- SCL Construction Guideline U10-2** (canceled); "Transformer Service Vaults and Padmounts, Customer's Responsibility, Outside Network Area"
- SCL Construction Guideline U10-2.1** (canceled); "Transformer Service Vault, In-Building, Dry, Outside Network Area"
- SCL Construction Guideline U10-2.2** (canceled); "Transformer Service Vault In-Building, With Outdoor, Below Ground Access, Outside Network Area"