Three-Phase Multi-Gain Deadend Pole Top Assemblies

1. Scope

This standard covers the information necessary to construct the pole top assemblies for three-phase deadend poles with multiple gains supporting #4 AWG copper, 397.5 and 954 kcmil ACSR and hardware. Installation instructions to connect the primary conductor to the pole are included.

Criteria for pole top assemblies covered under this standard include the following:

Grade of construction	B or C
Pole class	1 or stronger
Pole length	55 ft and 60 ft
Soil condition	Average
Allowable line angle	0°–60°

If a deadend is not required, refer to SCL 0123.21 and SCL 0123.23.

Composite, steel, laminated, and other non-wood poles are outside the scope of this standard.

2. Application

This standard provides direction to Seattle City Light (SCL) engineers, crews, and contractors for the installation of three-phase multi-gain deadend pole top assemblies on 26 kV distribution poles.

3. General Requirements

There are two configurations of three-phase multi-gain deadend pole tops: parallel deadend and perpendicular deadend. The configurations are constructed differently and the crossarms are located at different elevations.

Use Table 3a to determine which configuration is applicable.

Table 3a. Lower Gain Configurations

Configuration	Angle Between Crossarms	Pole Length (ft)	Figure
Parallel	0°–10°	60	3a
Perpendicular	10°–90°	55	3b

Two-phase deadend poles shall be constructed as three-phase deadend poles without the center phase.

The center phase line post insulator and jumper wire of the lower double deadend circuit shall be installed on the same side as the head pin (of the upper circuit) which is on the street side.

For single deadend poles, the crossarm gain plate shall be installed on the back side of the pole to oppose the conductor tension. See figures 3c and 3g.

For double-deadend poles, the crossarm gain plate shall be installed on the side of the pole opposite the larger conductor or greater conductor tension. See figures 3e and 3i.

Figure 3a. Parallel Deadend Configuration

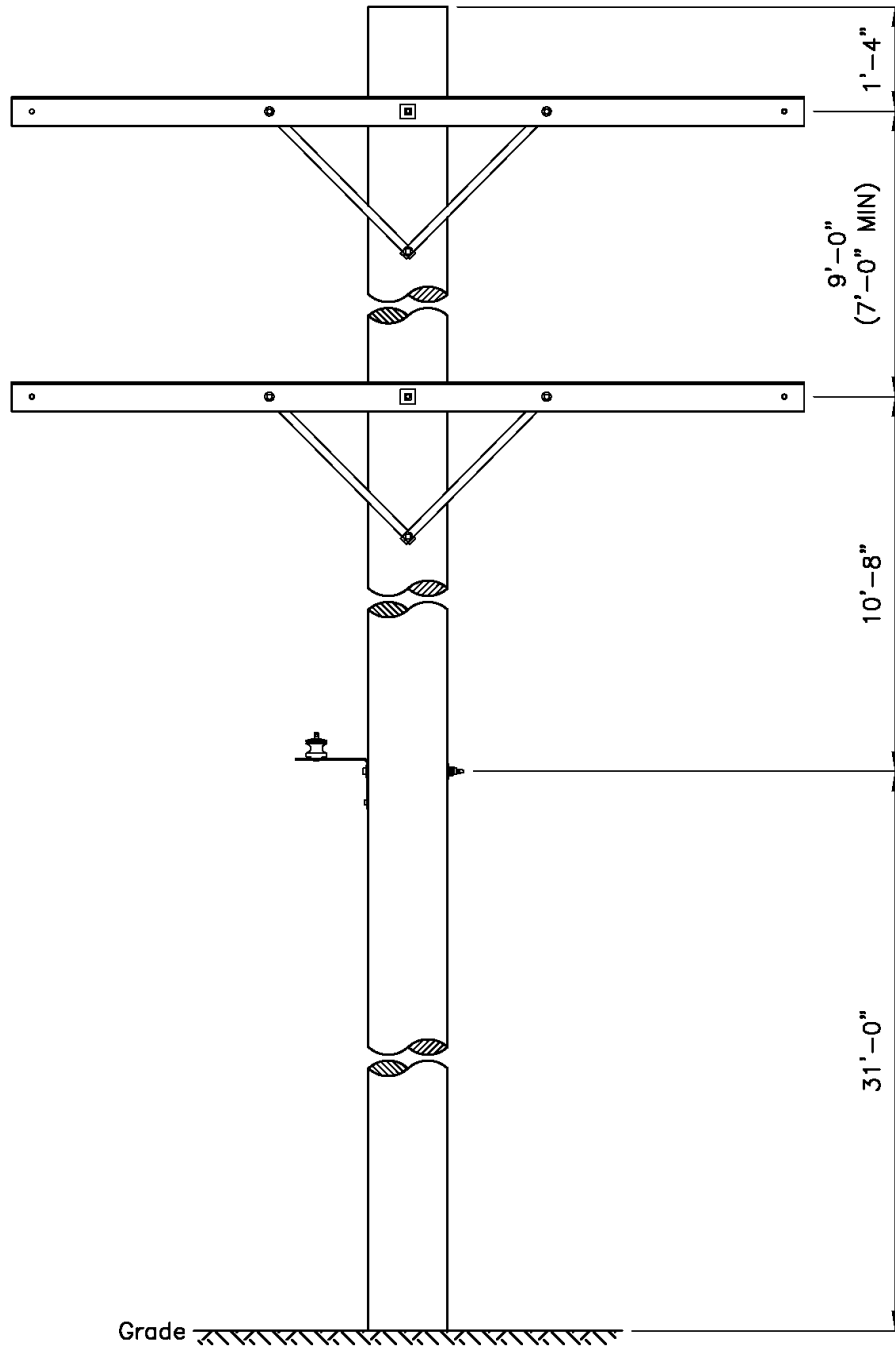
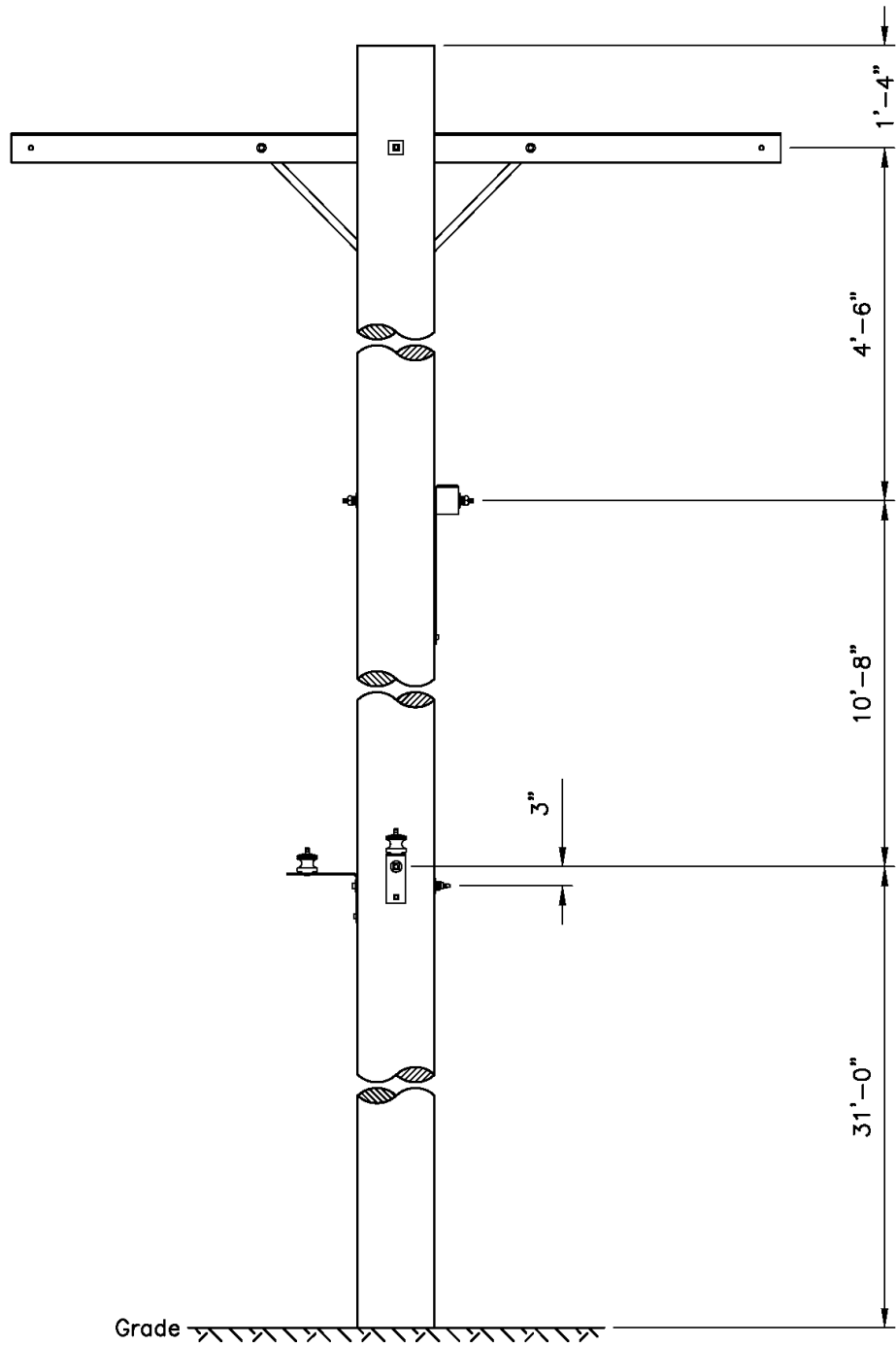

Figure 3b. Perpendicular Deadend Configuration



3.1 Upper Circuit Requirements

The upper gain shall be constructed as shown in SCL 0123.05.

3.2 Lower Circuit Requirements

The lower gain shall be constructed as shown in Table 3b and in Figures 3c through 3j.

Table 3b. Lower Gain Three-Phase Deadend Pole Assemblies

Conductor Size	Deadend Type	Allowable Line Angle	Figures
#4 AWG	Single	–	3c, 3d
#4 AWG	Double	0°–60°	3e, 3f
397.5 kcmil	Single	–	3g, 3h
397.5 kcmil	Double	0°–60°	3i, 3j
954 kcmil	Single	–	3g, 3h
954 kcmil	Double	0°–60°	3i, 3j

The single deadend poles shall have crossarms perpendicular to the primary conductor.

Deadend poles shall be guyed according to the requirements of SCL 0199.01.

The highest communication attachment shall be located a minimum of 40 in below the secondary and neutral, and a minimum of 10 ft below the top of the transformer.

Figure 3c. #4 AWG Copper Single Deadend, Top View

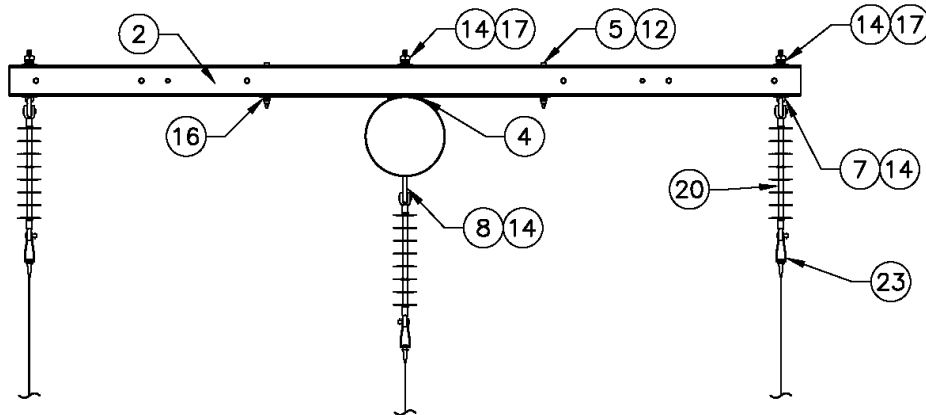

Figure 3d. #4 AWG Copper Single Deadend, Side View

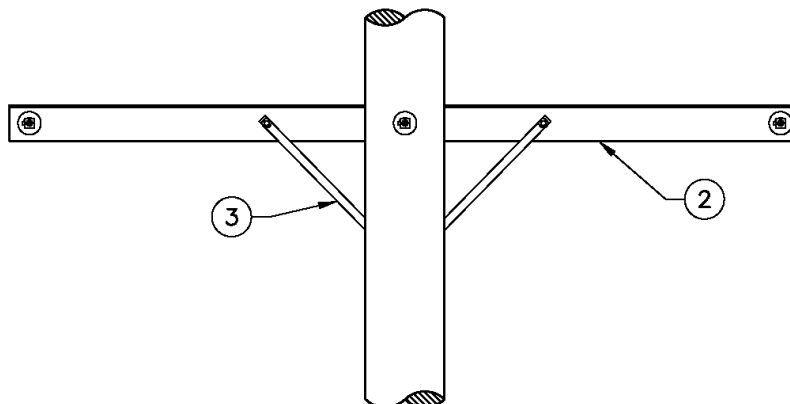

Figure 3e. Allowable Line Angle Range for #4 AWG Copper Double Deadend

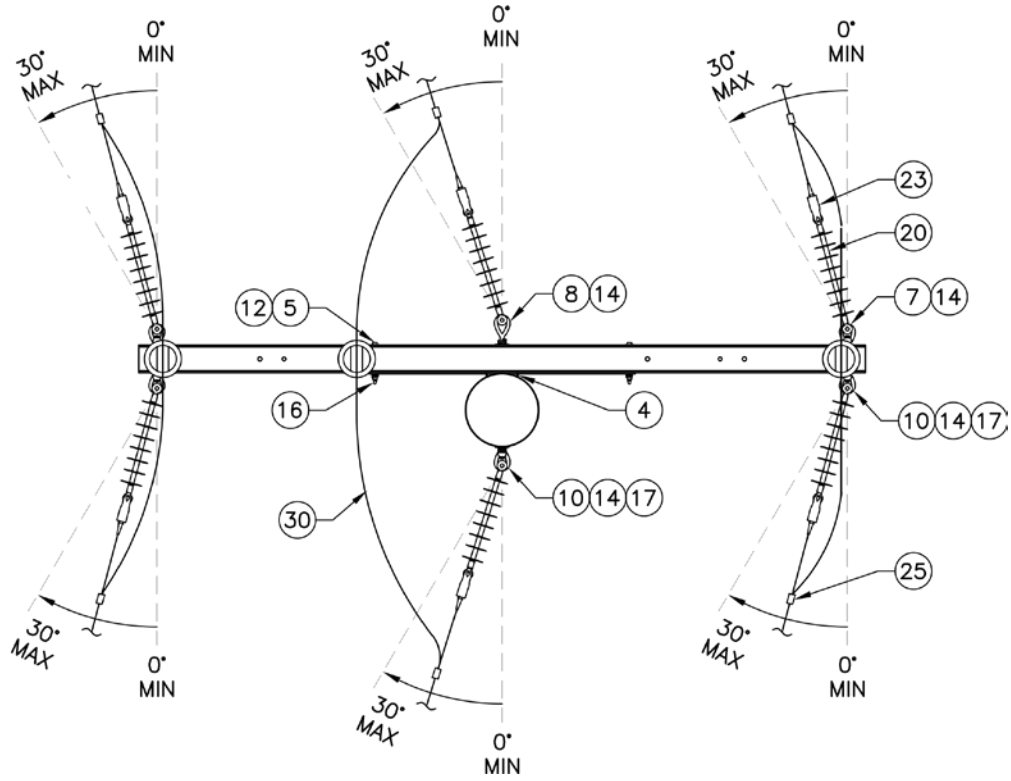

Figure 3f. #4 AWG Copper Double Deadend, Side View

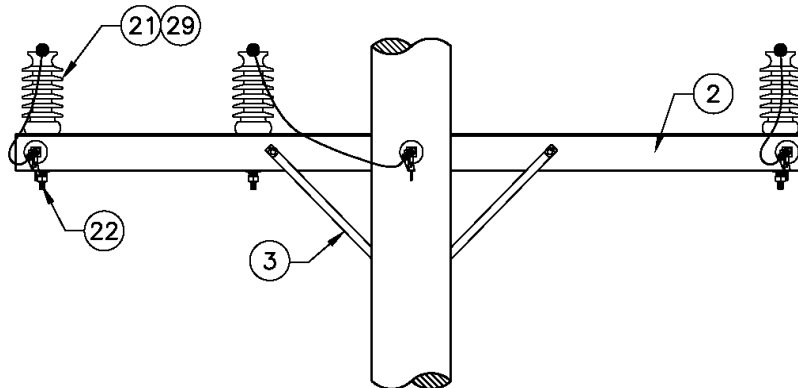

Figure 3g. 397.5 and 954 kcmil ACSR Single Deadend, Top View

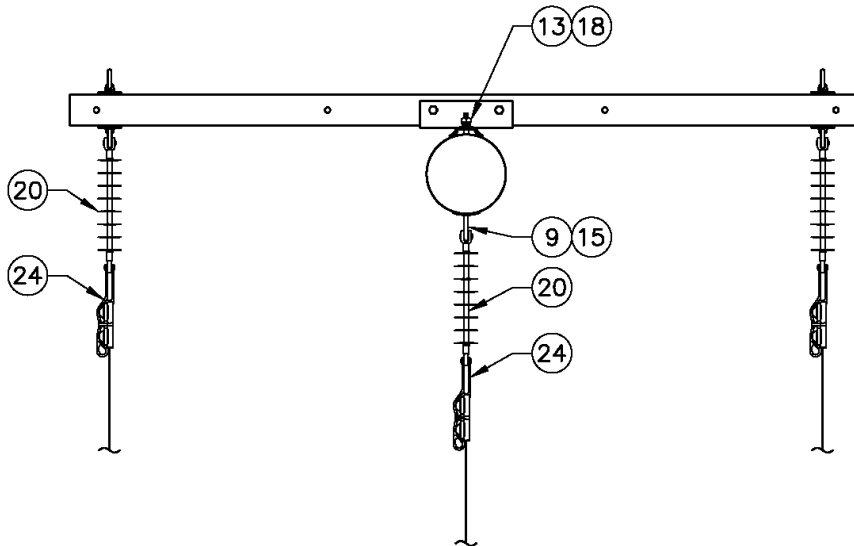

Figure 3h. 397.5 and 954 kcmil ACSR Single Deadend, Side View

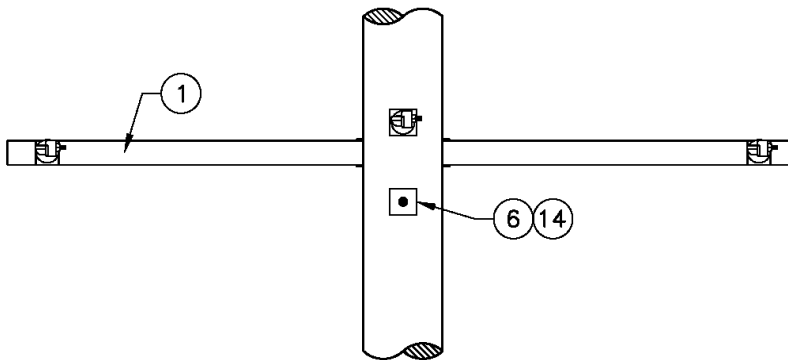

Figure 3i. Allowable Line Angle Range for 397.5 and 954 kcmil ACSR Double Deadend

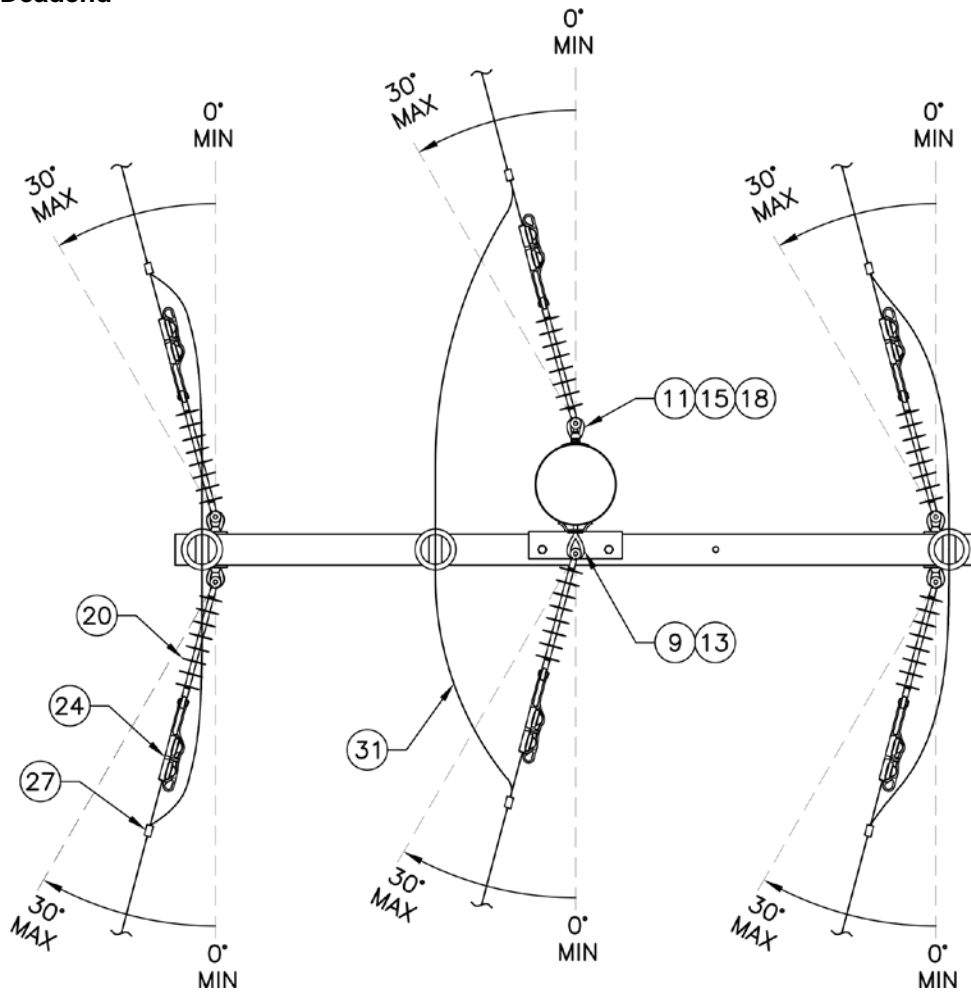
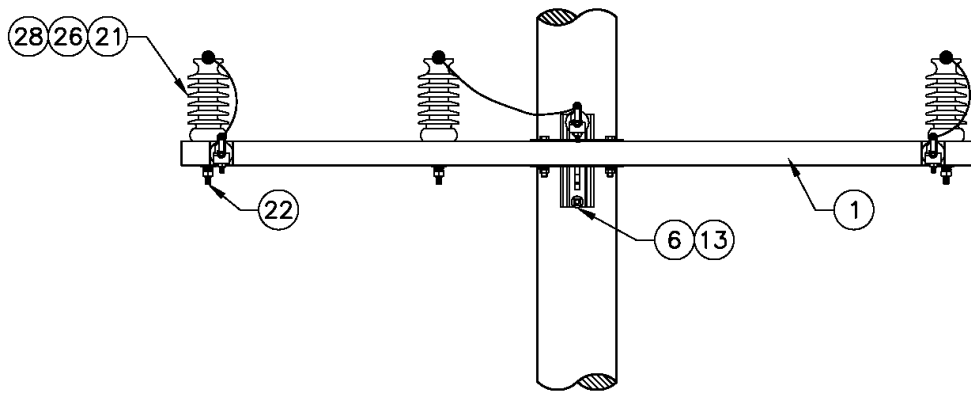

Figure 3j. 397.5 and 954 kcmil ACSR Double Deadend, Side View



4. Construction Notes

- The larger conductor should be installed as the top circuit.
- If poor soil is found in the field, contact the SCL Design Engineer.
- If there are avian and wildlife concerns, contact the SCL Design Engineer.
- If there are salt spray concerns, contact the SCL Design Engineer.

5. Material List

Table 5. Materials for the Lower Gain of Three-Phase Multi-Gain Deadend Pole Top Assemblies

Three-Phase Multi-Gain Deadend Pole Top Assemblies

Fig	Compatible Unit	ID	Quantity					
3c	Three-phase #4 AWG copper single deadend lower gain pole top assembly	PLT#4-3DEMG	[Diagram: Line from 3c to 3e]					
3e	Three-phase #4 AWG copper double deadend lower gain pole top assembly	PLT#4-3DDE60MG	[Diagram: Line from 3e to 3g]					
3g	Three-phase 397.5 kcmil ACSR single deadend lower gain pole top assembly	PLT397-DEMG	[Diagram: Line from 3g to 3i]					
3i	Three-phase 397.5 kcmil ACSR double deadend lower gain pole top assembly	PLT397-DDE60MG	[Diagram: Line from 3i to 3g]					
3g	Three-phase 954 kcmil ACSR single deadend lower gain pole top assembly	PLT954-DEMG	[Diagram: Line from 3g to 3i]					
3i	Three-phase 954 kcmil ACSR double deadend lower gain pole top assembly	PLT954-DDE60MG	[Diagram: Line from 3i to 3g]					

#	Material Description	ID	▼	▼	▼	▼	▼	▼
1	Crossarm, fiberglass, deadend, 10'	013636	1	1	1	1	-	-
2	Crossarm, 6 pin, 10'	540146	-	-	-	-	1	1
3	Crossarm, brace, flat, 32"	563005	-	-	-	-	2	2
4	Pole gain	565313	-	-	-	-	1	1
5	Bolt, machine, galvanized, 1/2" x 6"	780806	-	-	-	-	2	2
6	Bolt, machine, galvanized, 3/4" x 14"	780876	1	1	1	1	-	-
7	Bolt, oval eye, galvanized, 5/8" x 6"	561106	-	-	-	-	2	2
8	Bolt, oval eye, galvanized, 5/8" x 16"	561116	-	-	-	-	1	1
9	Bolt, oval eye, galvanized, 3/4" x 14"	561214	1	1	1	1	-	-
10	Nut, oval eye, 5/8"	565252	-	-	-	-	3	-
11	Nut, oval eye, 3/4"	565254	1	-	1	-	-	-
12	Washer, round, flat, 1/2"	585025	-	-	-	-	2	2
13	Washer, round, flat, 3/4"	585035	2	2	2	2	-	-
14	Washer, square, flat, 2-1/4" x 2-1/4"	585135	-	-	-	-	6	6
15	Washer, square, curved, 4" x 4"	584775	2	2	2	2	-	-
16	Washer, spring lock, 1/2"	584257	-	-	-	-	2	2
17	Washer, spring lock, 5/8"	584261	-	-	-	-	3	3
18	Washer, spring lock, 3/4"	584267	2	2	2	2	-	-
19	Lag screw, 1/2" x 4"	785261	-	-	-	-	1	1
20	Insulator, deadend, polymer, 20"	690233	6	3	6	3	6	3
21	Insulator, vertical line post, 34.5 kV, tie-top	690157	-	-	3	-	3	-
21	Insulator, vertical line post, 34.5 kV, clamp-top	690159	3	-	-	-	-	-
22	Stud, long, 3/4" x 7-1/2"	696828	3	-	3	-	3	-
23	Deadend, automatic, feed-through, #4 copper	581332	-	-	-	-	6	3
24	Clamp, deadend, straight line, for ACSR and AAC, #3/0-477	694292	-	-	6	3	-	-

Continued on the next page
 Continued from the previous page

#	Material Description	ID						
24	Clamp, deadend, straight line, for ACSR and AAC, 397–954	694294	6	3	–	–	–	–
25	Clamp, hot line tap, 2/0, #8	580725	–	–	–	–	6	–
26	Clamp, trunnion, line post, for ACSR and AAC, 0.99"–1.5"	695196	3	–	–	–	–	–
27	Connector, Ampact, 397–397	651101	–	–	6	–	–	–
27	Connector, Ampact, 954–954	651107	6	–	–	–	–	–
28	Insulator tie, top, 397.5, 0.756"–0.855"	658979	–	–	3	–	–	–
29	Wire, solid bare copper, dead-soft-annealed, insulator tie, #6 AWG (ft)	610210	–	–	–	–	18	–
30	Wire, solid bare copper, dead-soft-annealed, jumper, #4 AWG (ft)	610208	–	–	–	–	30	–
31	Wire, bare, AAC, jumper, 397.5, Canna (ft)	600113	–	–	30	–	–	–
31	Wire, bare, AAC, jumper, 954, Goldenrod (ft)	600126	30	–	–	–	–	–

6. References

SCL Construction Standard 0123.21; "Three-Phase Multi-Gain Tangent Pole Top Assemblies"

SCL Construction Standard 0123.23; "Three-Phase Multi-Gain Angle Pole Top Assemblies"

SCL Construction Standard 0199.01; "Requirements for Guying and Anchoring"

7. Sources

National Electrical Safety Code (NESC), C2–2012 Edition; Institute of Electrical and Electronics Engineers (IEEE) Inc., New York, NY, 2011

Hall, Alan; SCL Engineer and subject matter expert for 0123.25 (alan.hall@seattle.gov)

Lu, Curtis; SCL Standards Engineer and originator of 0123.25 (curtis.lu@seattle.gov)