

Three-Phase Multi-Gain Angle Pole Top Assemblies**1. Scope**

This standard covers the information necessary to construct the pole top assemblies for three-phase angle poles with multiple gains supporting #4 AWG copper, 397.5, and 954 kcmil ACSR and hardware. Installation instructions to connect the primary conductor to the pole are included.

Criteria for pole top assemblies covered under this standard include the following:

Grade of Construction	B or C
Pole Class	1 or stronger
Pole Length	55 ft or 60 ft
Soil Condition	Average
Allowable Line Angle	1°–30°

For line angles less than the allowable line angle described above, refer to SCL 0123.21.

For line angles greater than the allowable line angle described above, refer to SCL 0123.25.

Composite, steel, laminated, and other non-wood poles are outside the scope of this standard.

2. Application

This standard provides direction to Seattle City Light (SCL) engineers, crews, and contractors for the installation of three-phase multi-gain angle pole top assemblies on 26 kV distribution poles.

3. Requirements**3.1 General**

There are two configurations of three-phase multi-gain angle pole tops: parallel angle and perpendicular angle. The configurations are constructed differently and the crossarms are located at different elevations.

Use Table 3.1 to determine which configuration is applicable.

Table 3.1. Lower Gain Configurations

Configuration	Angle Between Crossarms	Pole Length (ft)	Figure
Parallel	0°–10°	60	3.1a
Perpendicular	10°–90°	55	3.1b

Two-phase angle poles shall be constructed as three-phase angle poles without the center phase.

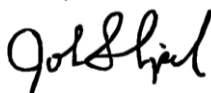
The center phase of the lower circuit shall be installed on the same side as the head pin which is the street side for an angle pole.

Figure 3.1a. Parallel Angle Configuration

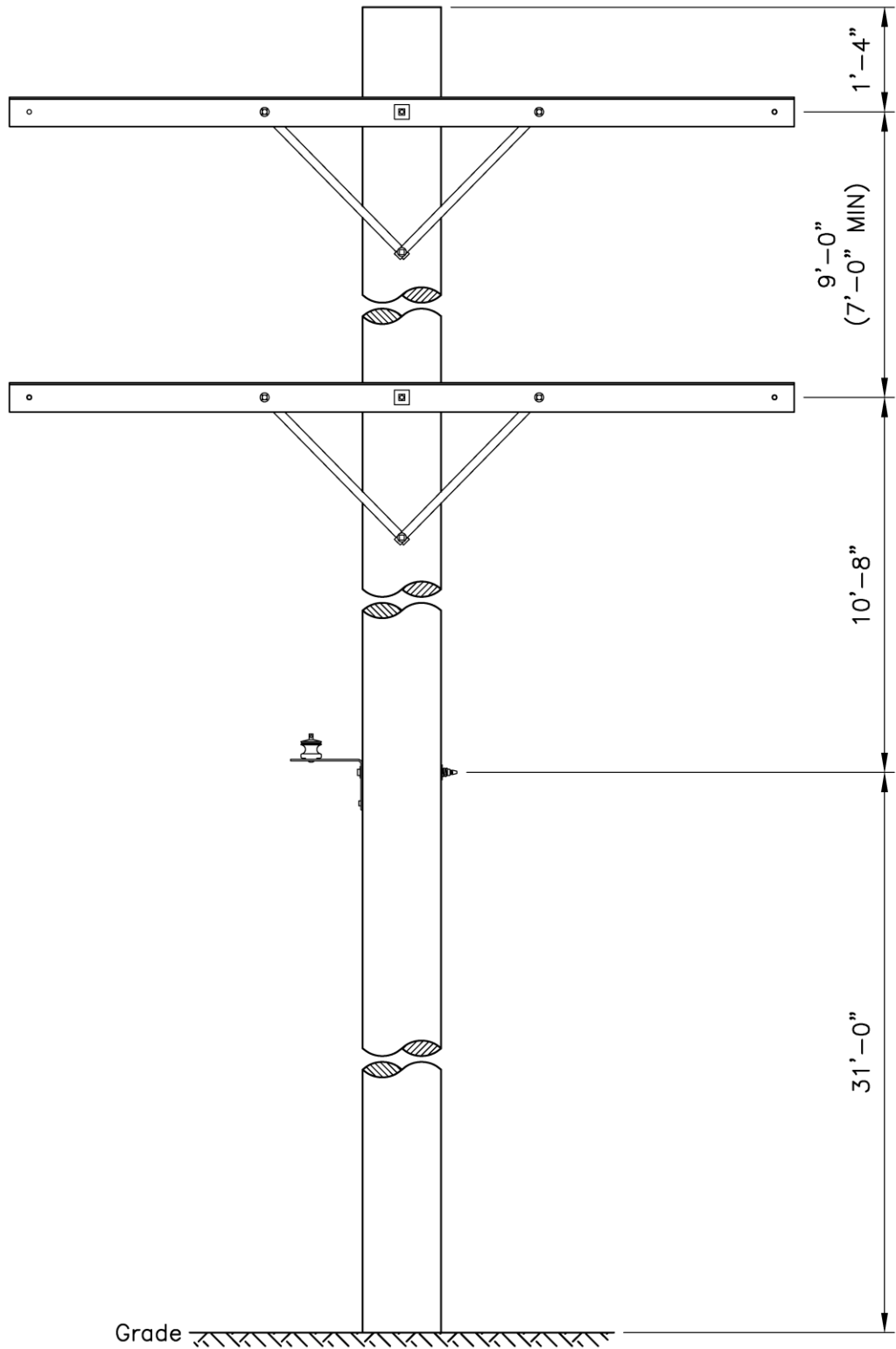
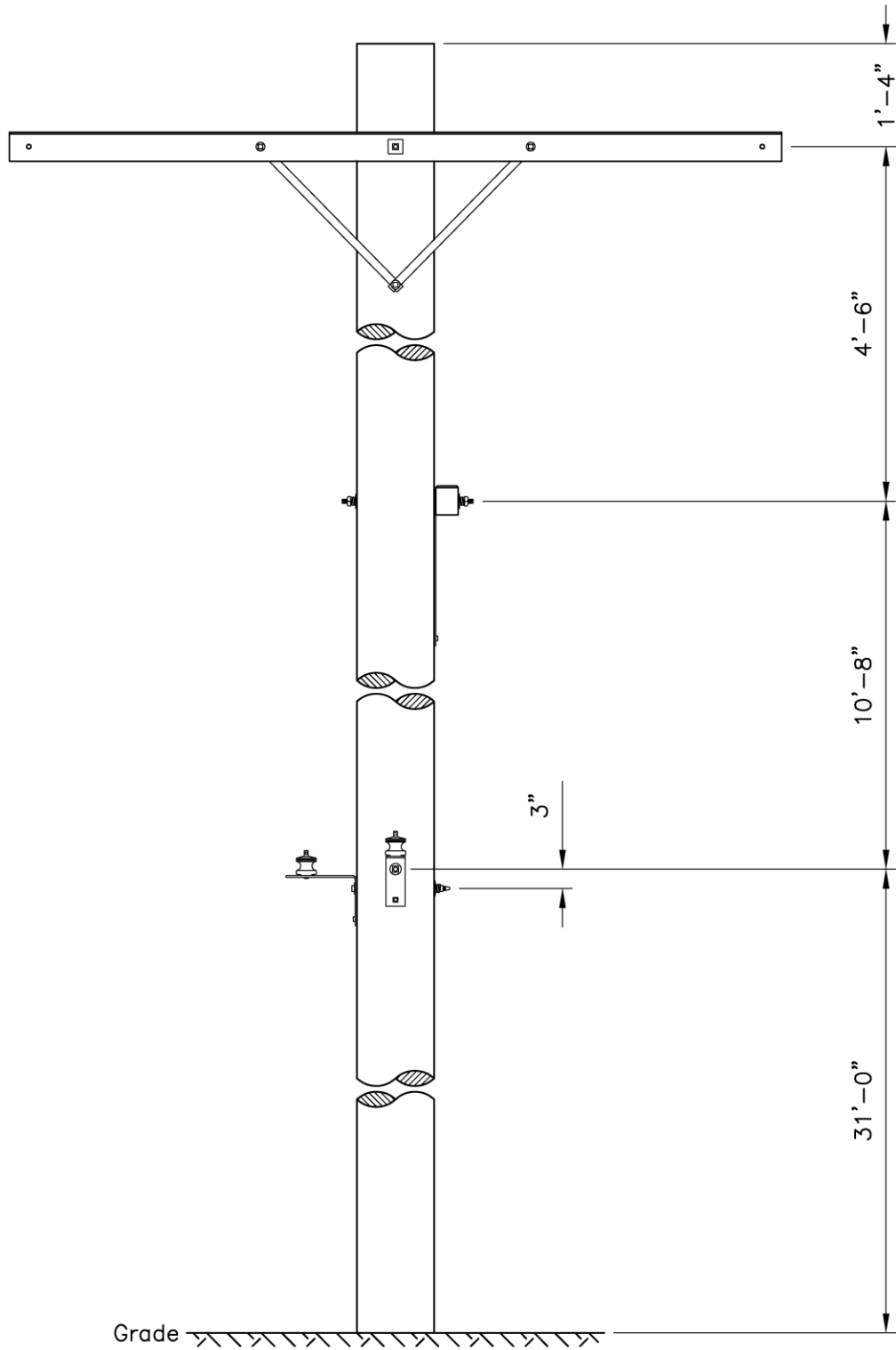

Figure 3.1b. Perpendicular Angle Configuration



3.2 Upper Circuit Requirements

The upper gain shall be constructed as shown in SCL 0123.03.

3.3 Lower Circuit Requirements

The lower gain shall be constructed as shown in Table 3.3.

Table 3.3. Lower Gain of Three-Phase Multi-Gain Angle Pole Top Assemblies

Conductor Size	Crossarm Type	Crossarm Number	Crossarm Brace	Grade of Construction	Allowable Line Angle (MIN-MAX)	Figure
#4 AWG	Universal	Single	Flat	C	7°-30°	3.3a, 3.3c
#4 AWG	Universal	Single	Flat	B	1°-30°	3.3a, 3.3c
397.5 kcmil	Feeder	Single	Flat	C	4°-18°	3.3a, 3.3d
397.5 kcmil	Feeder	Single	Flat	B	1°-14°	3.3a, 3.3d
397.5 kcmil	Feeder	Double	Flat	C	18°-30°	3.3b, 3.3d
397.5 kcmil	Feeder	Double	Flat	B	14°-28°	3.3b, 3.3d
954 kcmil	Feeder	Single	V-brace	C	3°-9°	3.3a, 3.3d
954 kcmil	Feeder	Single	V-brace	B	1°-7°	3.3a, 3.3d
954 kcmil	Feeder	Double	V-brace	C	9°-15°	3.3b, 3.3d
954 kcmil	Feeder	Double	V-brace	B	7°-14°	3.3b, 3.3d

The angles (X°) shown in the following figures are identified in Table 3.3.

Figure 3.3a. Allowable Line Angle Range for #4 AWG Copper, 397.5, and 954 kcmil ACSR Angle Lower Gain

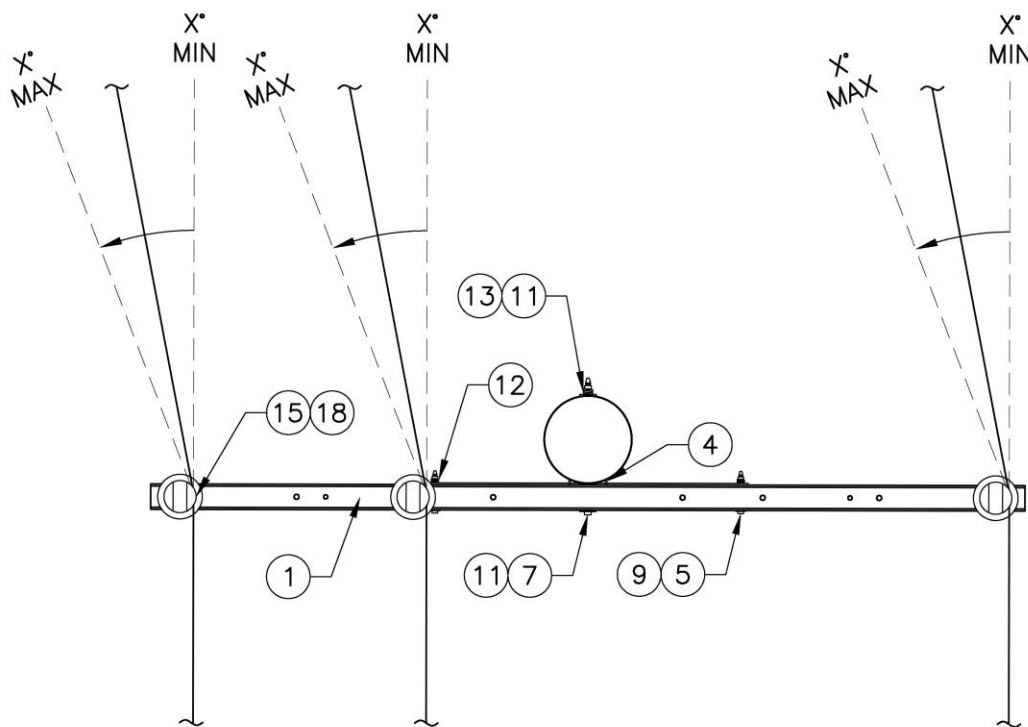

Figure 3.3b. Allowable Line Angle Range for 397.5 and 954 kcmil ACSR Angle Double Arm Lower Gain

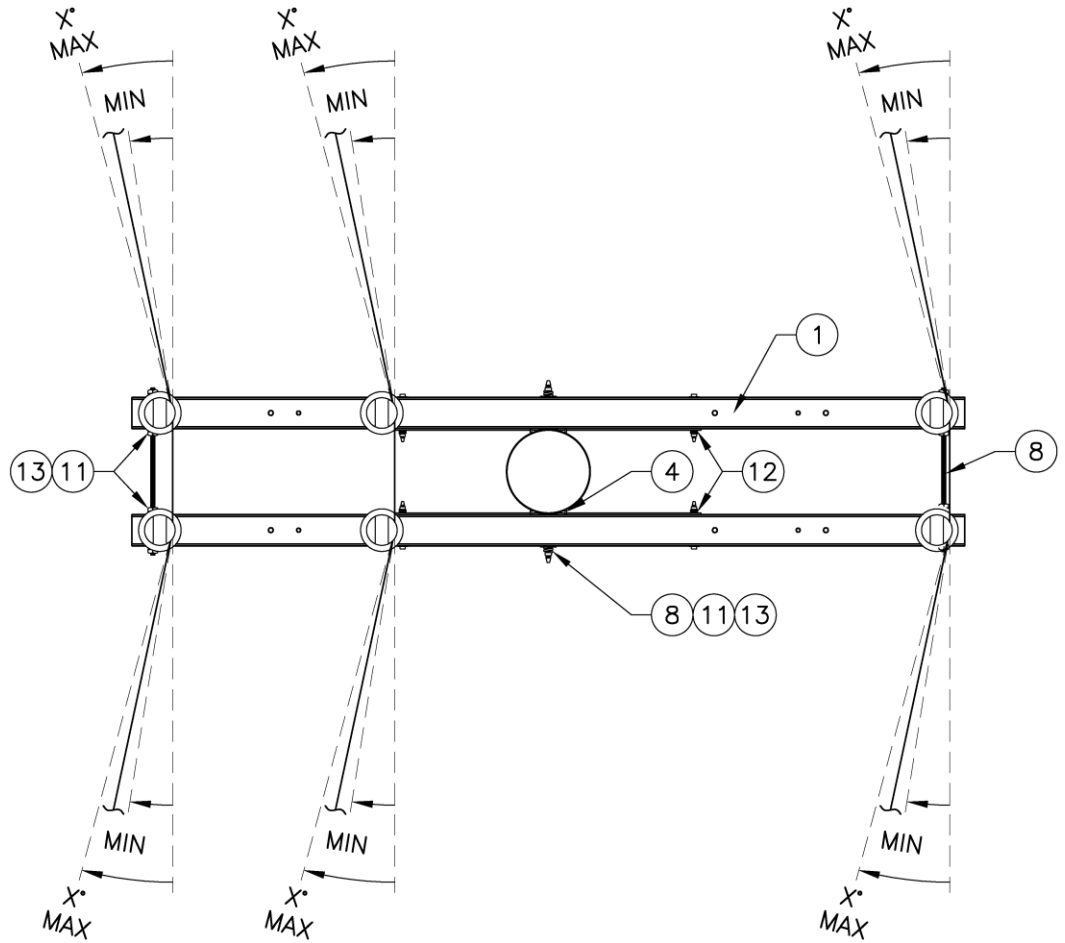

Figure 3.3c. #4 AWG Copper Lower Gain

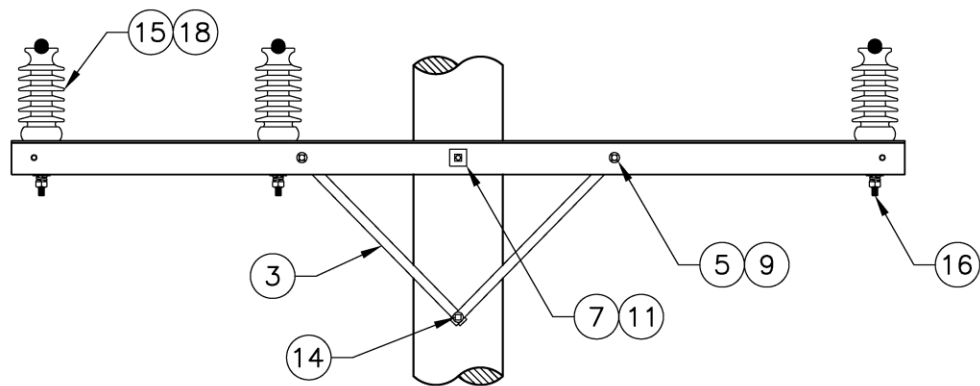
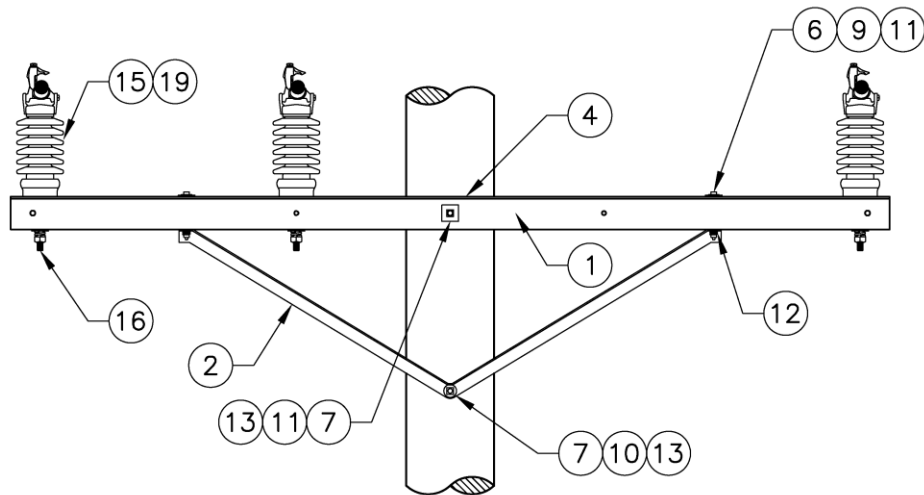

Figure 3.3d.397.5 kcmil and 954 kcmil ACSR Lower Gain



4. Construction Notes

- The larger conductor should be installed as the top circuit.
- If poor soil is found in the field, contact the SCL Design Engineer.
- If there are avian and wildlife concerns, contact the SCL Design Engineer.
- If there are salt spray concerns, contact the SCL Design Engineer.

5. Material List

Table 5. Materials for the Lower Gain of Three-Phase Multi-Gain Angle Pole Top Assemblies

Fig	Compatible Unit	ID	Quantity					
3.3c	Three-phase #4 AWG copper multi-gain angle pole	PLT#4-3ANG						
3.3d	Three-phase 397.5 kcmil ACSR multi-gain angle single arm pole	PLT397-ANG1						
3.3d	Three-phase 397.5 kcmil ACSR multi-gain angle double arm pole	PLT397-ANG2						
3.3d	Three-phase 954 kcmil ACSR multi-gain angle single arm pole	PLT954-ANG1						
3.3d	Three-phase 954 kcmil ACSR multi-gain angle double arm pole	PLT954-ANG2						
3.3c	Two-phase #4 AWG copper multi-gain angle pole	PLT#4-2ANG						
#	Material Description	ID	1	2	3	4	5	6
1	Crossarm, 8 pin, 10'	540220	1	-	-	-	-	1
1	Crossarm, 6 pin, 10'	540146	-	2	1	2	1	-
2	Crossarm, brace, V	563010	-	2	1	-	-	-
3	Crossarm, brace, flat, 32"	563005	2	-	-	4	2	2
4	Gain plate	565313	1	2	1	2	1	1
5	Bolt, machine, galvanized, 1/2" x 5"	780804	2	-	-	-	-	2
5	Bolt, machine, galvanized, 1/2" x 6"	780806	-	-	-	4	2	-
6	Bolt, machine, galvanized, 1/2" x 7"	780808	-	4	2	-	-	-
7	Bolt, machine, galvanized, 5/8" x 14"	780846	2	2	1	1	1	2
7	Bolt, machine, galvanized, 5/8" x 16"	780847	-	-	1	-	1	-
8	Bolt, double arming, galvanized, 5/8" x 22"	560522	-	3	-	3	-	-
9	Washer, round, flat, 1/2"	585025	2	4	2	2	2	2
10	Washer, round, flat, 5/8"	585030	1	3	4	1	1	1
11	Washer, square, flat, 2-1/4" x 2-1/4"	585135	3	11	6	11	3	3
12	Washer, spring lock, 1/2"	584257	2	4	2	4	2	2
13	Washer, spring lock, 5/8"	584261	2	12	3	11	2	2
14	Screw, lag, 1/2" x 4"	785261	2	1	1	3	2	2
15	Insulator, post top, 34.5 kV, tie top	014304	2	-	-	-	-	3
15	Insulator, post top, 34.5 kV, clamp top	690159	-	3	3	6	3	-
16	Stud long, 3/4" x 7-1/2"	696828	2	3	3	6	3	3
17	Bracket, LR	690404	1	1	1	1	1	1
18	Wire tie, insulator, #6 Cu solid, bare, soft	610210	6	-	-	-	-	9
19	Clamp, trunnion, line post, 0.5"-1.06"	695193	-	-	-	6	3	-
19	Clamp, trunnion, line post, 0.99"-1.5"	695196	-	3	3	-	-	-

6. References

SCL Construction Standard 0123.03; “Three-Phase Angle Pole Top Assemblies”

SCL Construction Standard 0123.21; “Three-Phase Multi-Gain Tangent Pole Top Assemblies”

SCL Construction Standard 0123.25; “Three-Phase Multi-Gain Deadend Pole Top Assemblies”

7. Sources

National Electrical Safety Code (NEC) C2–2012 Edition; Institute of Electrical and Electronics Engineers (IEEE) Inc., New York, NY, 2011

Hall, Alan; SCL Senior Electrical Engineer and subject matter expert for 0123.23 (alan.hall@seattle.gov)

Lu, Curtis; SCL Standards Engineer and originator of 0123.23 (curtis.lu@seattle.gov)