

Three-Phase Multi-Gain Tangent Pole Top Assemblies

1. Scope

This standard covers the information necessary to construct the pole top assemblies for three-phase tangent poles with multiple gains supporting #4 AWG copper, 397.5 kcmil ACSR and 954 kcmil ACSR primary conductors on the 26 kV primary distribution system. Installation instructions for connecting the primary conductor to the pole are included, along with requirements for vertical spacing and hardware.

Criteria for pole top assemblies covered under this standard include the following:

Grade of construction	B or C
Pole class	1 or stronger
Pole length	55 ft or 60 ft
Soil condition	Average
Allowable line angle	0°–8°

For line angles greater than the allowable line angle described above, refer to SCL 0123.23.

Composite, steel, laminated and other non-wood poles are outside the scope of this standard.

2. Application

This standard provides direction to Seattle City Light (SCL) engineers, crews and contractors for the installation of three-phase multi-gain tangent pole top assemblies on 26 kV distribution poles.

3. General Requirements

There are two configurations of three-phase multi-gain tangent pole tops; parallel tangent and perpendicular tangent. The configurations are constructed differently and the cross arms are located at different elevations.

Use Table 3a to determine which configuration is applicable.

Table 3a. Lower Gain Configurations

Configuration	Angle Between Crossarms	Minimum Required Pole Length (ft)	Figure
Parallel	0°–10°	60	3a
Perpendicular	10°–90°	55	3b





The perpendicular tangent configuration requires an additional LR bracket and is installed as shown as a corner pole in SCL 0100.11.

Two-phase tangent poles shall be constructed as three-phase tangent poles without the center phase.

The center phase of the lower circuit shall be installed on the same side as the head pin, which is the street side for a tangent pole.

Figure 3a. Parallel Tangent Configuration

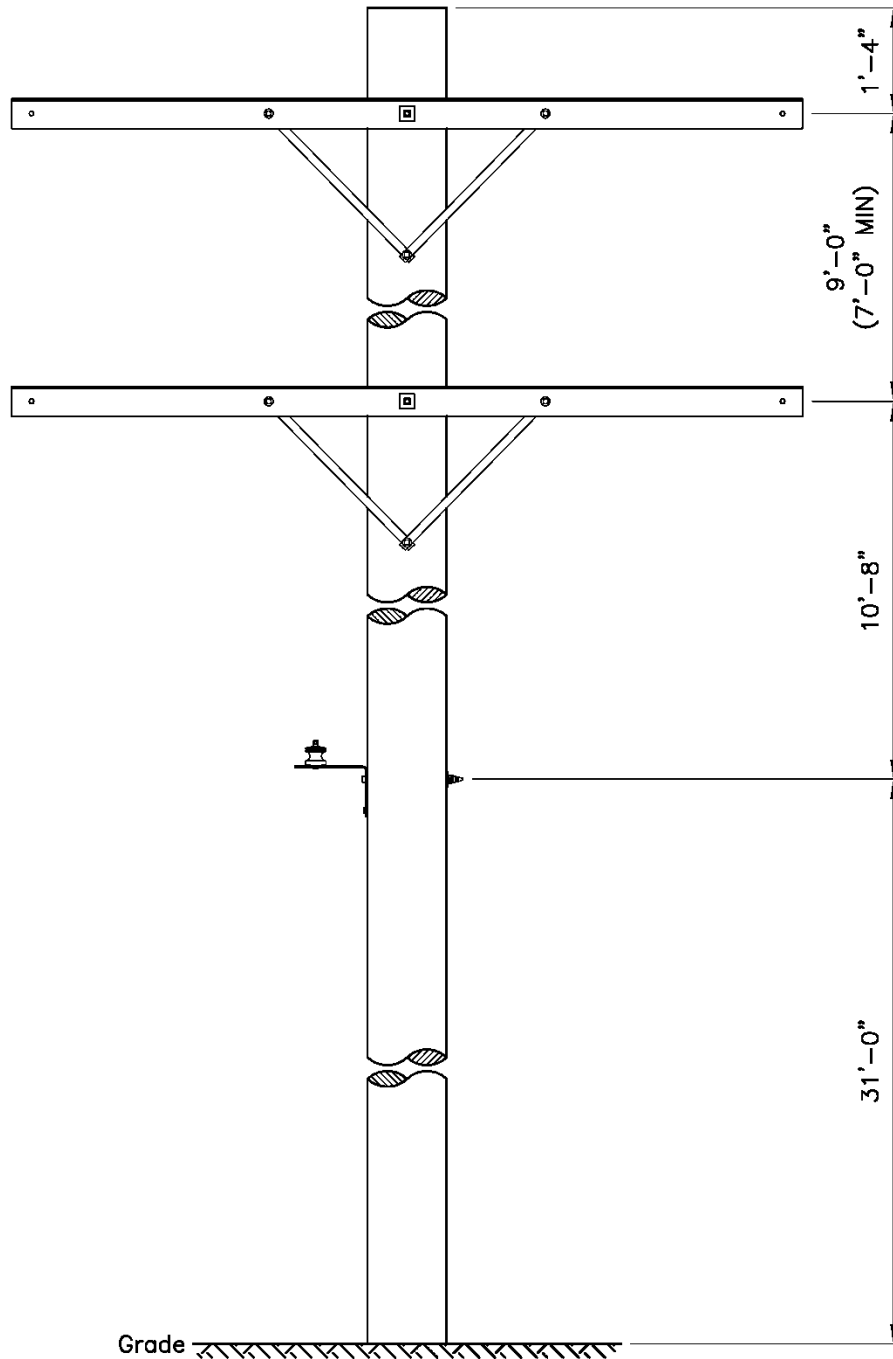
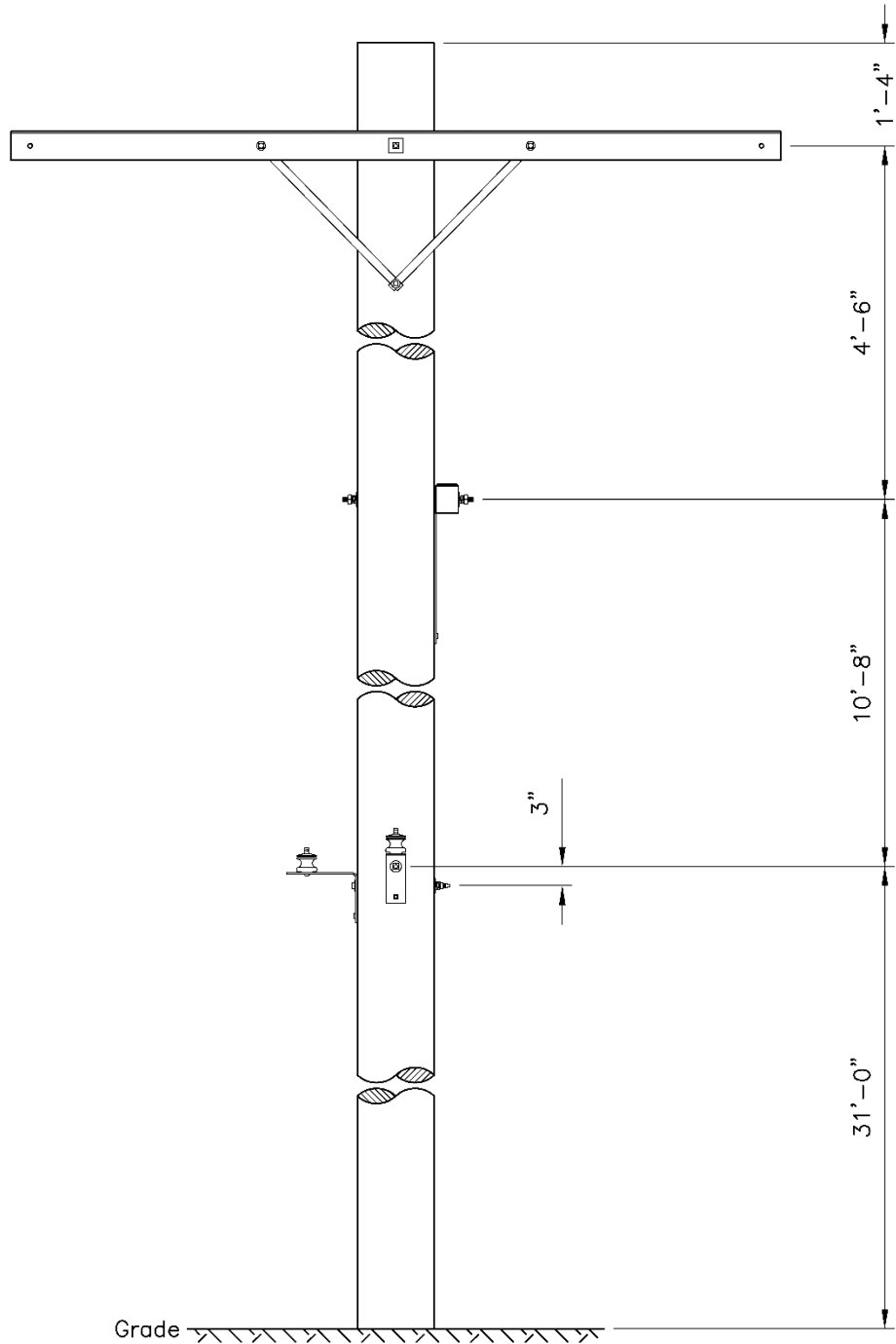

Figure 3b. Perpendicular Tangent Configuration



3.1 Upper Gain Requirements

The upper gain shall be constructed as shown in SCL 0123.01.

3.2 Lower Gain Requirements

The lower gain shall be constructed as shown in Table 3b.

Table 3b. Lower Gain of Three-Phase Multi-Gain Tangent Pole Top Assemblies

Conductor Size	Grade of Construction	Allowable Line Angle	Figure
#4 AWG	B and C	0°–8°	3c, 3d
397.5 kcmil	B and C	0°–3°	3e, 3g
954 kcmil	C	0°–3°	3f, 3g
954 kcmil	B	0°–3°	3f, 3h

Figure 3c. Allowable Line Angle Range for #4 AWG Copper Tangent Lower Gain

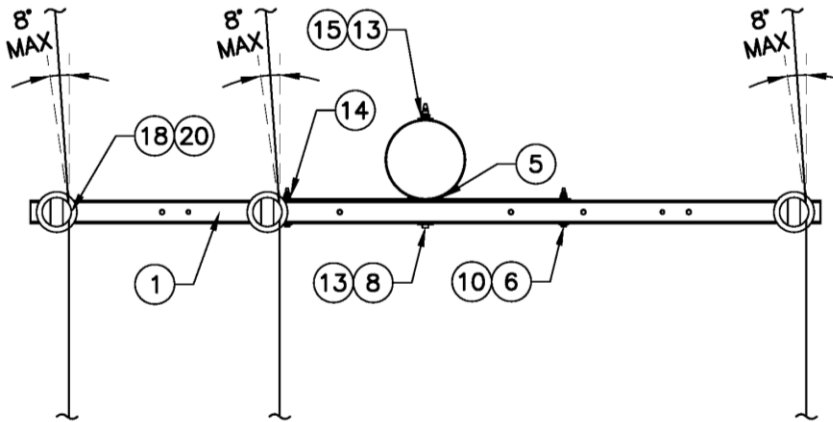

Figure 3d. #4 AWG Copper Lower Gain of a Three-Phase Multi-Gain Tangent Pole Top Assembly

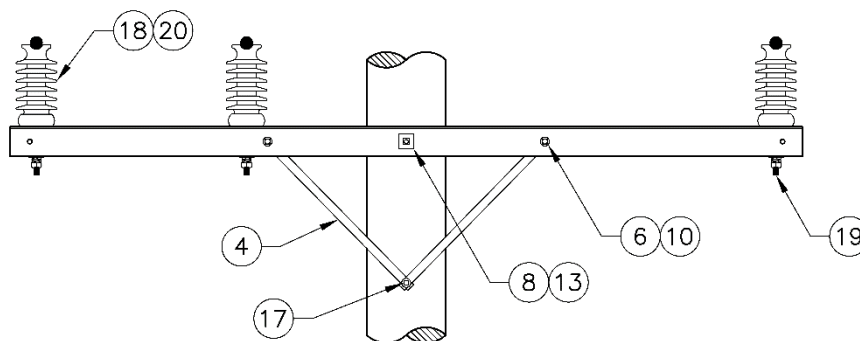

Figure 3e. Allowable Line Angle Range for 397.5 kcmil ACSR Tangent Lower Gain

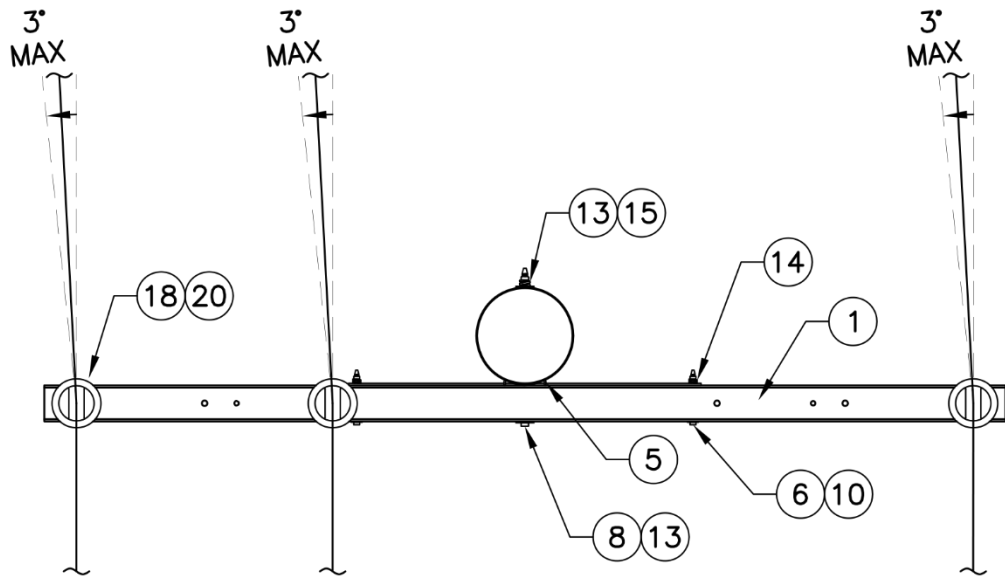

Figure 3f. Allowable Line Angle Range for 954 kcmil ACSR Tangent Lower Gain

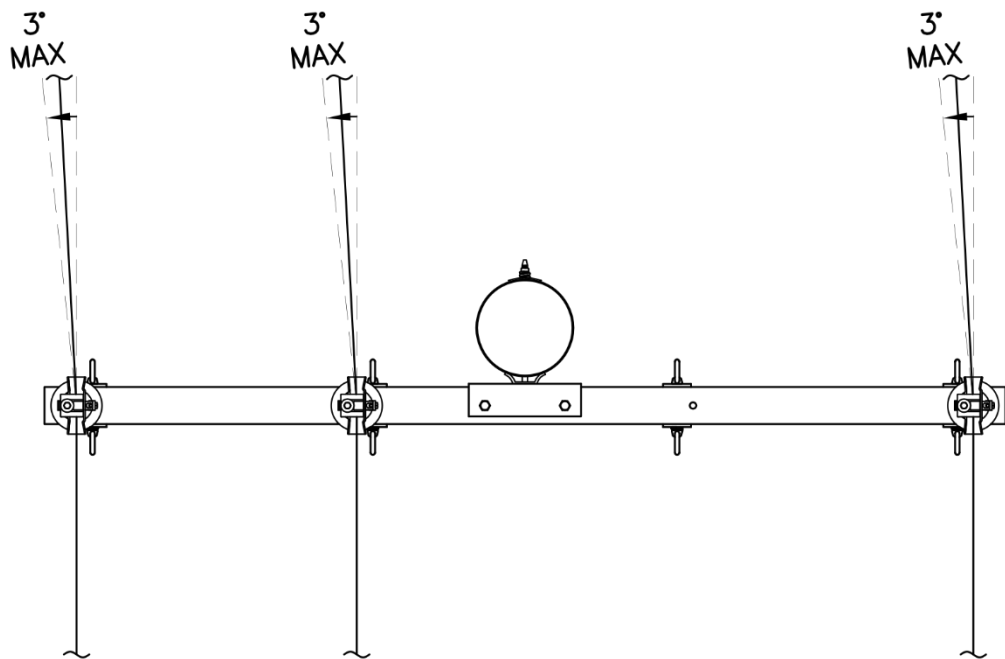

Figure 3g. Grade B & C 397.5 and Grade C 954 kcmil ACSR Lower Gain of a Three-phase Multi-Gain Tangent Pole Top Assembly

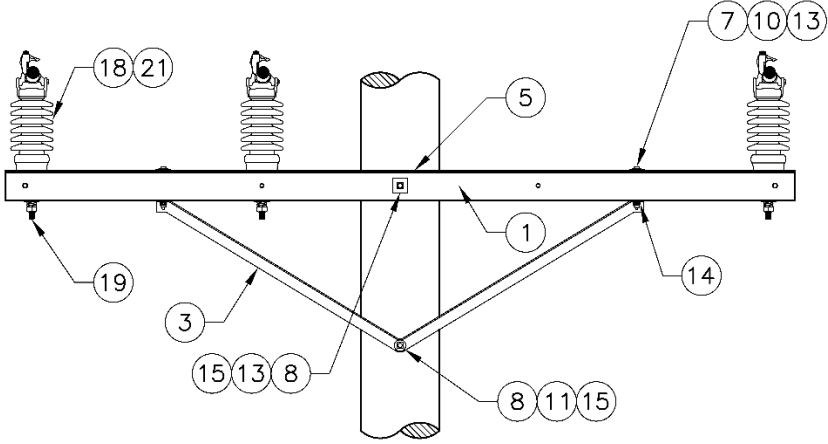
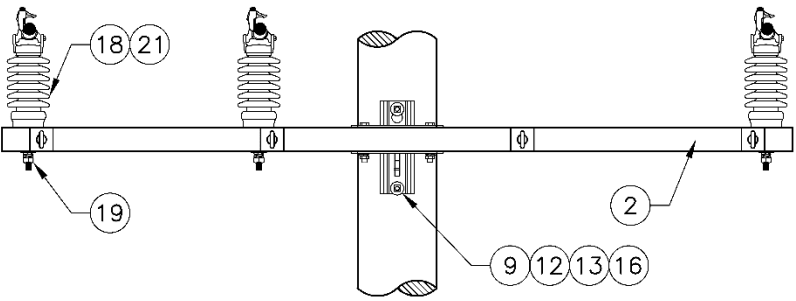

Figure 3h. Grade B 954 kcmil ACSR Lower Gain of a Three-Phase Multi-Gain Tangent Pole Top Assembly



4. Construction Notes

- The larger conductor should be installed as the top circuit.
- If poor soil is found in the field, contact the SCL Design Engineer.
- If there are avian and wildlife concerns, contact the SCL Design Engineer.
- If there are salt spray concerns, contact the SCL Design Engineer.

5. Material Lists

Table 5. Materials for the Lower Gain of Three-Phase Multi-Gain Tangent Pole Top Assemblies

Fig	Compatible Unit	ID	Quantity				
3d	Three-phase #4 AWG Cu multi-gain tangent pole	PLT#4-3TAN					
3g	Three-phase 397.5 kcmil ACSR multi-gain tangent pole	PLT397-TAN					
3g	Three-phase 954 kcmil ACSR grade C multi-gain tangent pole	PLT954-TANC					
3h	Three-phase 954 kcmil ACSR grade B multi-gain tangent pole	PLT954-TANB					
3d	Three-phase #4 AWG Cu multi-gain tangent pole	PLT#4-2TAN					
#	Material Description	ID	1	2	3	4	5
1	Crossarm, 8 pin, 10'	540220	1	-	-	-	1
1	Crossarm, 6 pin, 10'	540146	-	-	1	1	-
2	Crossarm, fiberglass, deadend, 10'	013636	-	1	-	-	-
3	Crossarm, brace, V	563010	-	-	1	-	-
4	Crossarm, brace, flat, 32"	563005	2	-	-	2	2
5	Gain plate	565313	1	-	1	1	1
6	Bolt, machine, galvanized, 1/2" x 5"	780804	2	-	-	-	2
6	Bolt, machine, galvanized, 1/2" x 6"	780806	-	-	-	2	-
7	Bolt, machine, galvanized, 1/2" x 7"	780808	-	-	2	-	-
8	Bolt, machine, galvanized, 5/8" x 14"	780846	1	-	1	-	1
8	Bolt, machine, galvanized, 5/8" x 16"	780847	-	-	1	1	-
9	Bolt, machine, galvanized, 3/4" x 14"	780876	-	2	-	-	-
10	Washer, round, flat, 1/2"	585025	2	-	2	2	2
11	Washer, round, flat, 5/8"	585030	-	-	1	-	-
12	Washer, round, flat, 3/4"	585035	-	2	-	-	-
13	Washer, square, flat, 2-1/4" x 2-1/4"	585135	2	2	5	2	2
14	Washer, spring lock, 1/2"	584257	2	-	2	2	2
15	Washer, spring lock, 5/8"	584261	1	-	2	1	1
16	Washer, spring lock, 3/4"	584267	-	2	-	-	-
17	Screw, lag, 1/2" x 4"	785261	1	-	-	1	1
18	Insulator, post top, 34.5 kV, tie top	014304	2	-	-	-	3
18	Insulator, post top, 34.5 kV, clamp top	690159	-	3	3	3	-
19	Stud, long, 3/4" x 7-1/2"	696828	2	3	3	3	3
20	Wire tie, insulator, #6 AWG, Cu solid, bare, SD	610210	6	-	-	-	9
21	Clamp, trunnion, line post, .99"-1.5"	695196	-	3	3	-	-
21	Clamp, trunnion, line post, 0.5"-1.06"	695193	-	-	-	3	-

6. References

SCL Construction Standard 0100.11; “LR Bracket Installation”

SCL Construction Standard 0123.01; “Three-Phase Tangent Pole Top Assemblies”

SCL Construction Standard 0123.23; “Three-Phase Multi-Gain Angle Pole Top Assemblies”

7. Sources

National Electrical Safety Code (NESC); C2-2012 Edition; Institute of Electrical and Electronics Engineers (IEEE) Inc., New York, NY, 2011

Hall, Alan; SCL Senior Electrical Engineer and subject matter expert for 0123.21 (alan.hall@seattle.gov)

Lu, Curtis; SCL Standards Engineer and originator of 0123.21 (curtis.lu@seattle.gov)