

---

## Three-Phase Deadend Pole Top Assemblies

---

### 1. Scope

This standard covers the information necessary to construct the pole top assemblies for two- and three-phase deadend poles supporting #4 AWG copper, 397.5 kcmil ACSR, and 954 kcmil ACSR primary conductors on the 26 kV primary distribution system.

Requirements for vertical spacing and hardware, and installation instructions to connect the primary conductor to the pole are included.

Criteria for pole top assemblies covered under this standard include the following:

<b>Grade of construction</b>	B or C
<b>Pole class</b>	1 or stronger
<b>Pole length</b>	50 ft
<b>Soil condition</b>	Average
<b>Allowable line angle</b>	0°–60°

If a deadend is not required, refer to SCL 0123.01 and SCL 0123.03.

For line angles greater than the allowable line angle described above, contact the SCL Engineer.

Composite, steel, laminated, and other non-wood poles are outside the scope of this standard.

---

### 2. Application

This standard provides direction to Seattle City Light (SCL) engineers, crews, and contractors for the installation of two- and three-phase deadend assemblies on 26 kV distribution poles with #4 AWG copper, 397.5 kcmil ACSR, and 954 kcmil ACSR primary conductors.

---

### 3. General Requirements

Two-phase deadend poles shall be constructed as three-phase deadend poles without the center phase.

Three-phase deadend poles shall be constructed as shown in Table 3.





**Table 3. Three-Phase Deadend Pole Top Assemblies**

Conductor Size	Deadend Type	Allowable Line Angle	Figures
#4 AWG	Single	–	3a, 3b
#4 AWG	Double	0°–60°	3c, 3d
397.5 kcmil	Single	–	3e, 3f
397.5 kcmil	Double	0°–60°	3g, 3h
954 kcmil	Single	–	3e, 3f
954 kcmil	Double	0°–60°	3g, 3h

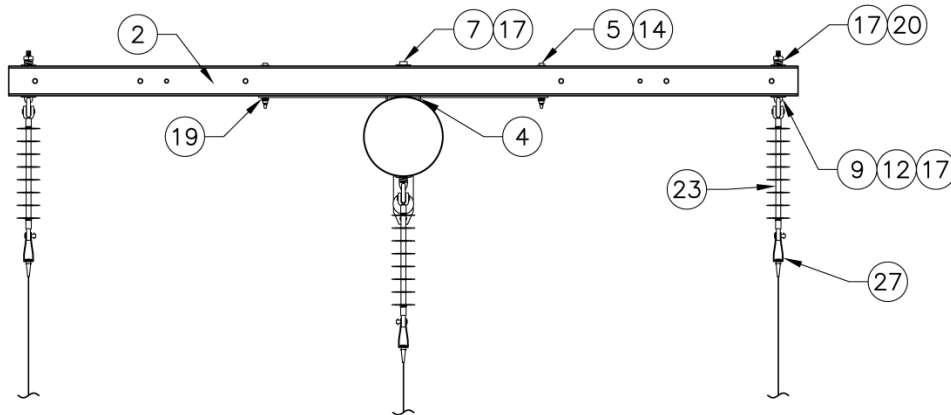
Single deadend poles shall have crossarms perpendicular to the primary conductor. The crossarm gain plate shall be installed on the back side of the pole to oppose the conductor tension. See figures 3a and 3e.

For double-deadend poles, the crossarm gain plate shall be installed on the side of the pole opposite the larger conductor or greater conductor tension. See figures 3c and 3g.

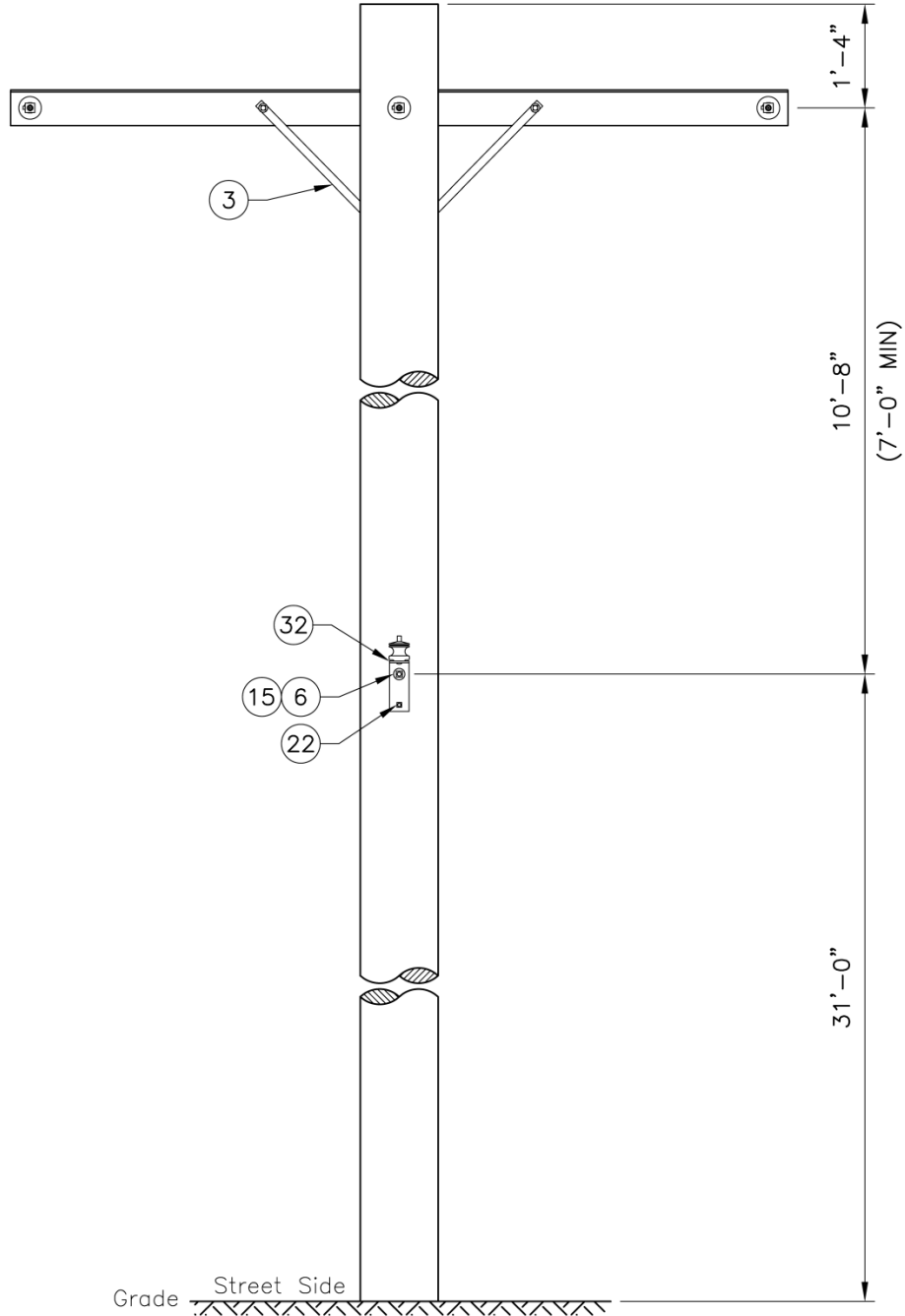
Deadend poles shall be guyed according to SCL 0199.01.

The highest communication attachment shall be located a minimum of 40 inches below the secondary and neutral, and a minimum of 10 ft below the top of the transformer.

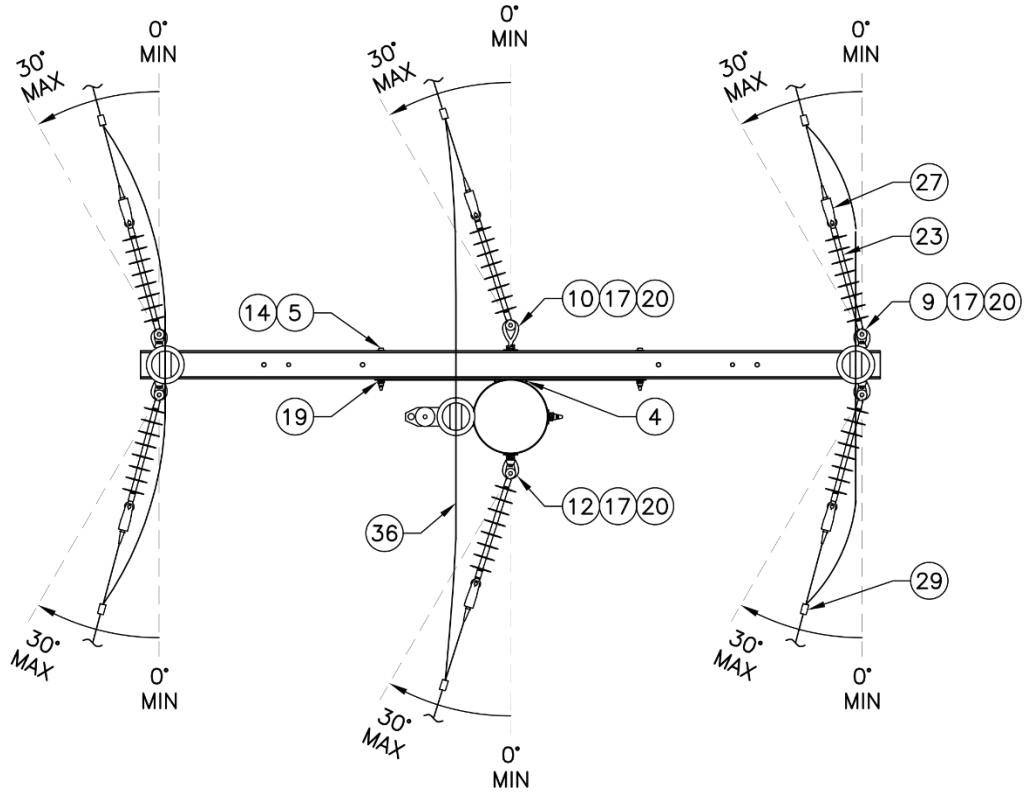
**Figure 3a. Three-Phase #4 AWG Copper Single Deadend Pole Top Assembly, Top View**



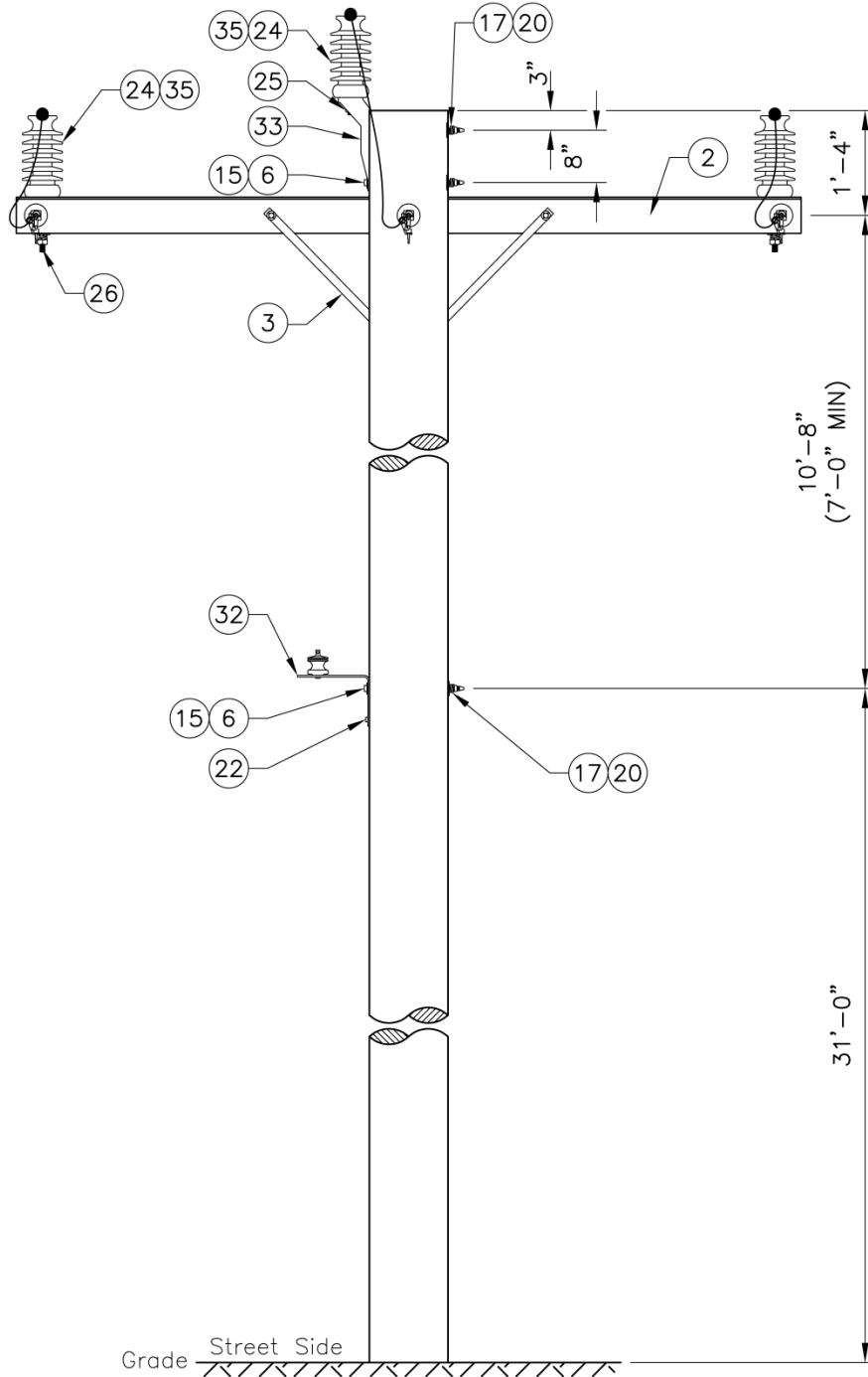
**Figure 3b. Three-Phase #4 AWG Copper Single Deadend Pole Top Assembly, Side View**



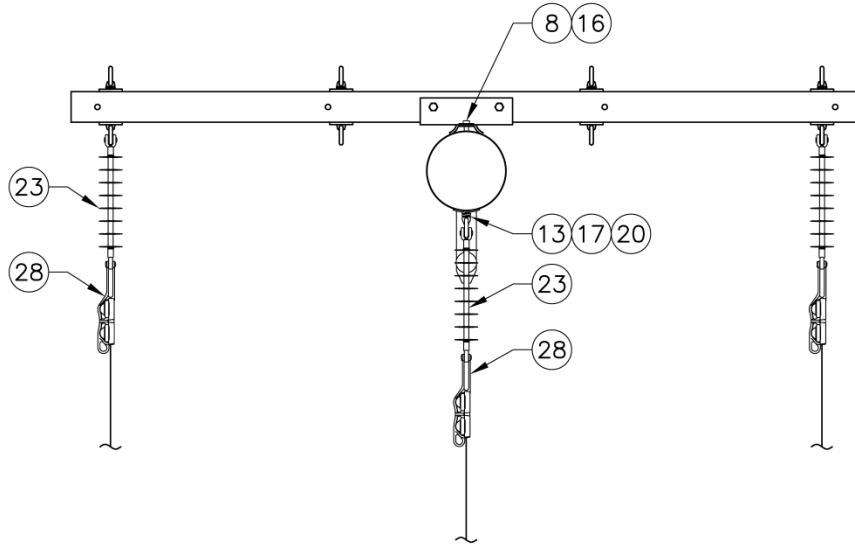
**Figure 3c. Allowable Line Angle Range for #4 AWG Copper Double Deadend Pole**



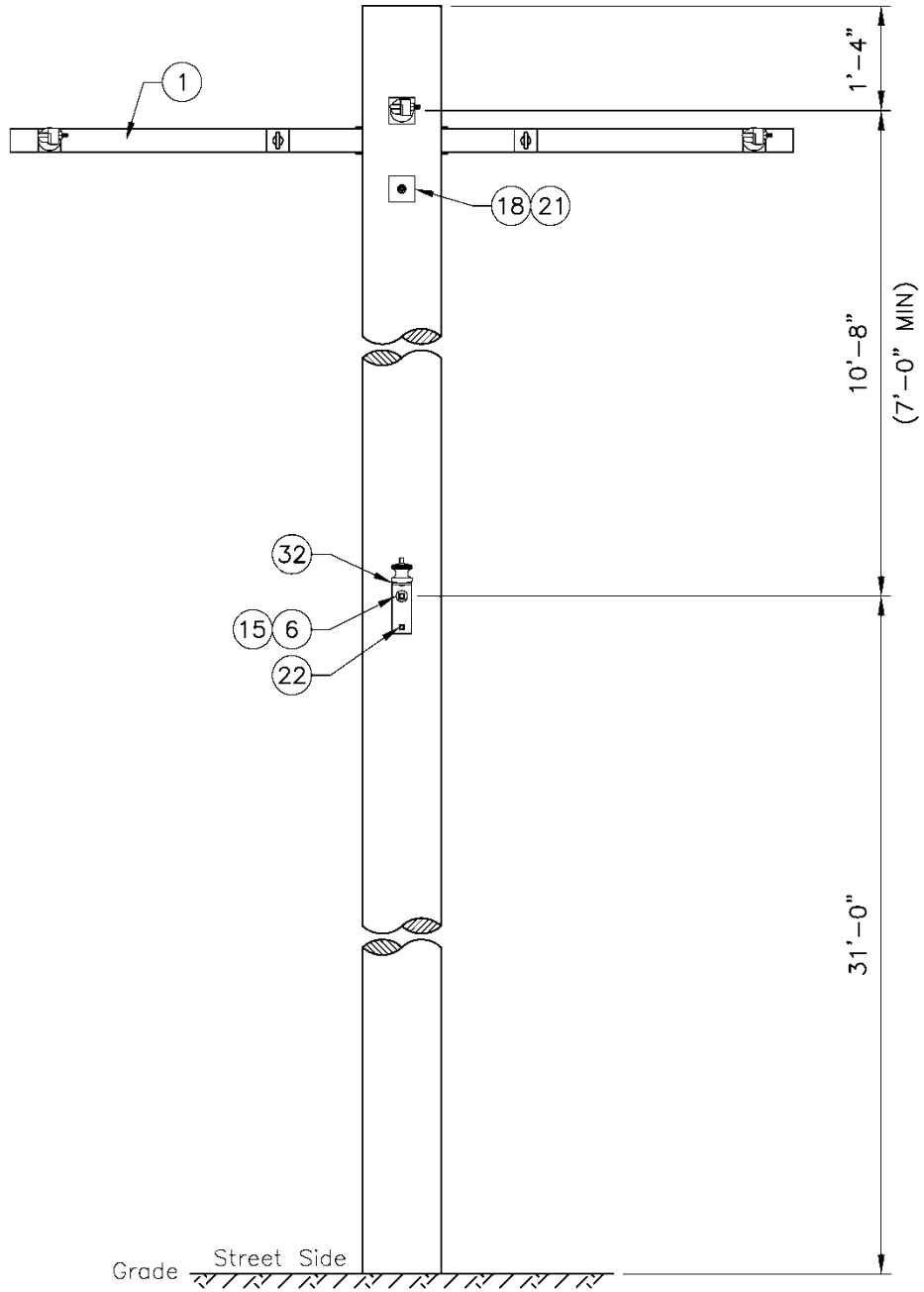
**Figure 3d. Three-Phase #4 AWG Copper Double Deadend Pole Top Assembly**



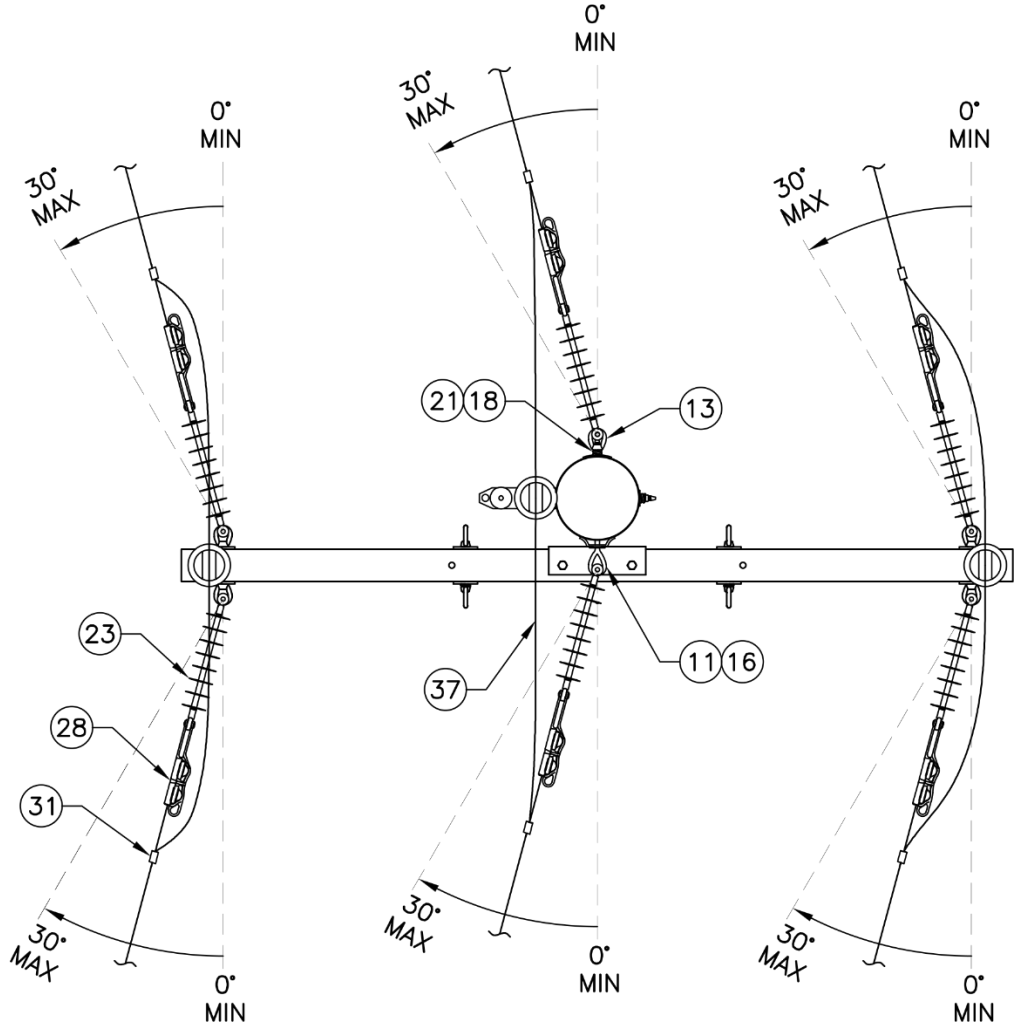
**Figure 3e. Three-Phase 397.5 and 954 kcmil ACSR Single Deadend Pole Top Assembly, Top View**



**Figure 3f. Three-Phase 397.5 and 954 kcmil ACSR Single Deadend Pole Top Assembly, Side View**

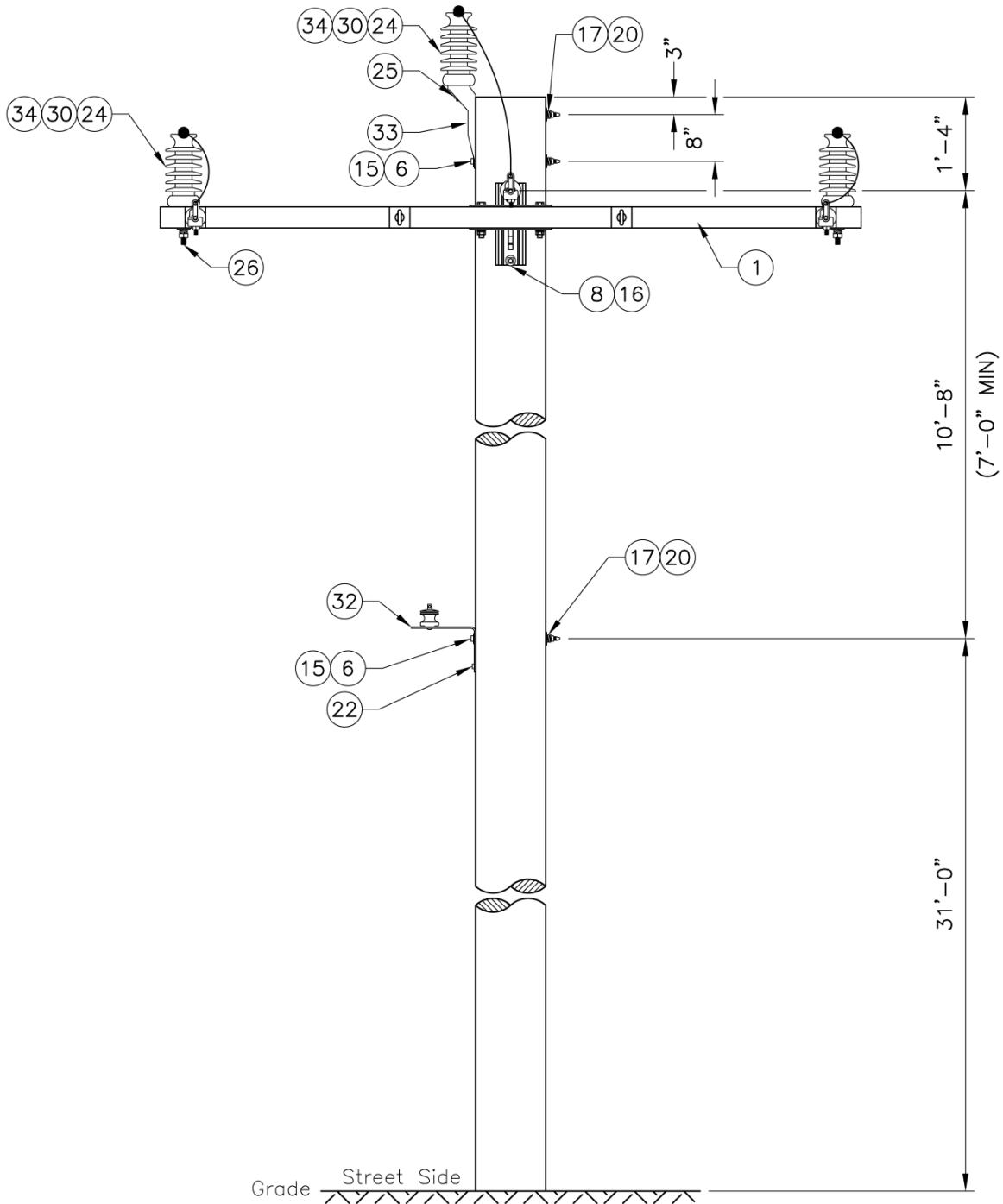


**Figure 3g. Allowable Line Angle Range for 0°–60° 397.5 and 954 kcmil ACSR  
Double Deadend Pole**





**Figure 3h. Three-Phase 397.5 and 954 kcmil ACSR Double Deadend Pole Top Assembly**



**4. Construction Notes**

If two neutrals are required, mount the second neutral on the street side 1 ft below the top bolt hole of the original neutral.

If poor soil is found in the field, contact the SCL Design Engineer.

If there are avian and wildlife concerns, contact the SCL Design Engineer.

If there are salt spray concerns, contact the SCL Design Engineer.

**5. Material Lists**

**Table 5a. Materials for Three-Phase Deadend Pole Top Assemblies**

Fig	Compatible Unit	ID	Quantity					
3b	Three-phase #4 AWG copper single deadend pole top assembly	PLT#4-3DE						
3d	Three-phase #4 AWG copper double deadend pole top assembly (0°–60°)	PLT#4-3DDEHP						
3f	Three-phase 397.5 kcmil ACSR single deadend pole top assembly	PLT397-DE						
3h	Three-phase 397.5 kcmil ACSR double deadend pole top assembly (0°–60°)	PLT397-DDEHP						
3f	Three-phase 954 kcmil ACSR single deadend pole top assembly	PLT954-DE						
3h	Three-phase 954 kcmil ACSR double deadend pole top assembly (0°–60°)	PLT954-DDEHP						

#	Material Description	ID	↓	↓	↓	↓	↓	↓
1	Crossarm, fiberglass, deadend - 10'	013636	1	1	1	1	-	-
2	Crossarm, 6 pin - 10'	540146	-	-	-	-	1	1
3	Crossarm, brace, flat - 32"	563005	-	-	-	-	2	2
4	Pole gain	565313	-	-	-	-	1	1
5	Bolt, machine, galvanized - 1/2" x 6"	780806	-	-	-	-	2	2
6	Bolt, machine, galvanized - 5/8" x 14"	780846	3	1	3	1	3	1
7	Bolt, machine, galvanized - 5/8" x 16"	780847	-	-	-	-	-	1
8	Bolt, machine, galvanized - 3/4" x 14"	780876	1	2	1	2	-	-
9	Bolt, oval Eye, galvanized - 5/8" x 6"	561106	-	-	-	-	3	2
10	Bolt, oval Eye, galvanized - 5/8" x 16"	561116	-	-	-	-	1	-
11	Bolt, oval Eye, galvanized - 3/4" x 14"	561214	1	-	1	-	-	-
12	Nut, oval eye - 5/8"	565252	-	-	-	-	3	3
13	Nut, oval eye - 3/4"	565254	1	1	1	1	-	-
14	Washer, round, flat - 1/2"	585025	-	-	-	-	2	2
15	Washer, round, flat - 5/8"	585030	3	1	3	1	3	1
16	Washer, round, flat - 3/4"	585035	2	2	2	2	-	-
17	Washer, square, flat - 2-1/4" x 2-1/4"	585135	3	1	3	1	13	7
18	Washer, square, curved - 4" x 4"	584775	2	2	2	2	-	-
19	Washer, spring lock - 1/2"	584257	-	-	-	-	2	2
20	Washer, spring lock - 5/8"	584261	3	1	3	1	4	4
21	Washer, spring lock - 3/4"	584267	2	2	2	2	-	-
22	Lag screw - 1/2" x 4"	785261	1	1	1	1	2	2
23	Insulator, deadend, polymer - 20"	690233	6	3	6	3	6	3

Continued on the next page.

*Continued from the previous page.*

#	Material Description	ID							
24	Insulator, vertical line-post, 34.5 kV, tie-top	690157	-	-	3	-	3	-	-
24	Insulator, vertical line-post, 34.5 kV, clamp-top	690159	3	-	-	-	-	-	-
25	Stud, short - 3/4" x 1-3/4"	696826	1	-	1	-	1	-	-
26	Stud, long - 3/4" x 7-1/2"	696828	2	-	2	-	2	-	-
27	Deadend, automatic, feed-through - #4 Cu	581332	-	-	-	-	6	3	-
28	Clamp, DE, straight line, for ACSR & AAC, #3/0-477	694292	-	-	6	3	-	-	-
28	Clamp, DE, straight line, for ACSR & AAC, 397-954	694294	6	3	-	-	-	-	-
29	Clamp, hot line tap - 2/0 - #8	580725	-	-	-	-	6	-	-
30	Clamp, trunion, line post, for ACSR & AAC, .99"-1.5"	695196	3	-	-	-	-	-	-
31	Connector, Ampact - 397-397	651101	-	-	6	-	-	-	-
31	Connector, Ampact - 954-954	651107	6	-	-	-	-	-	-
32	Bracket, LR	690404	1	1	1	1	1	1	1
33	Bracket, pole top	563253	1	-	1	-	1	-	-
34	Insulator tie, top, 397.5, 0.756"-0.855"	658979	-	-	3	-	-	-	-
35	Wire, solid bare Cu, dead-soft-annealed, insulator tie, #6 AWG, (ft)	610210	-	-	-	-	9	-	-
36	Wire, solid bare Cu, dead-soft-annealed, jumper, #4 AWG, (ft)	610208	-	-	-	-	30	-	-
37	Wire, bare, AAC, jumper, 397.5, canna, (ft)	600113	-	-	30	-	-	-	-
37	Wire, bare, AAC, jumper, 954, goldenrod, (ft)	600126	30	-	-	-	-	-	-

**Table 5b. Materials for Two-Phase Deadend Pole Top Assemblies**

Fig	Compatible Unit	ID	Quantity	
3b	Two-phase #4 AWG Copper Single Deadend Pole Top Assembly	PLT#4-2DE		
3d	Two-Phase #4 AWG Copper Double Deadend Pole Top Assembly (0°–60°)	PLT#4-2DDEHP		
#	Material Description	ID		
1	Crossarm, 6 Pin - 10'	540146	1	1
2	Crossarm, Brace, Flat - 32"	563005	2	2
3	Pole Gain	565313	1	1
4	Bolt, Machine, Galvanized - 1/2" x 6"	780806	2	2
5	Bolt, Machine, Galvanized - 5/8" x 14"	780846	1	1
6	Bolt, Machine, Galvanized - 5/8" x 16"	780847	1	1
7	Bolt, Oval Eye, Galvanized - 5/8" x 6"	561106	2	2
8	Nut, Oval Eye - 5/8"	565252	2	–
9	Washer, Round, Flat - 1/2"	585025	2	2
10	Washer, Round, Flat - 5/8"	585030	1	1
11	Washer, Square, Flat - 2-1/4" x 2-1/4"	585135	7	7
12	Washer, Spring Lock - 1/2"	584257	2	2
13	Washer, Spring Lock - 5/8"	584261	4	4
14	Lag Screw - 1/2" x 4"	785261	2	2
15	Insulator, Deadend, Polymer - 20"	690233	4	2
16	Insulator, Vertical Line-Post, 34.5 kV, Tie Top	690157	2	–
17	Stud, Long - 3/4" x 7-1/2"	696828	2	–
18	Deadend, Automatic, Feed-Through - #4 Copper	581332	4	2
19	Clamp, Hot Line Tap - 2/0 - #8	580725	4	–
20	Bracket, LR	690404	1	1
21	Wire, Solid Bare Copper, Dead-Soft-Annealed, Insulator Tie, #6 AWG (Feet)	610210	6	–
22	Wire, Solid Bare Copper, Jumper, #4 AWG (ft)	610208	20	–

## 6. References

- SCL Construction Standard 0199.01**; “Requirements for Guying and Anchoring”
  - SCL Construction Standard 0123.01**; “Three-Phase Tangent Pole Top Assemblies”
  - SCL Construction Standard 0123.03**; “Three-Phase Angle Pole Top Assemblies”
- 

## 7. Sources

- National Electrical Safety Code (NEC) C2-2012 Edition**; Institute of Electrical and Electronics Engineers (IEEE) Inc., New York, NY, 2011
- Hall, Alan**; SCL Senior Electrical Engineer and subject matter expert for 0123.05 (alan.hall@seattle.gov)
- Lu, Curtis**; SCL Standards Engineer and originator of 0123.05 (curtis.lu@seattle.gov)