Three-Phase Tangent Pole Top Assemblies

1. Scope

This standard covers the information necessary to construct the pole top assemblies for two and three-phase tangent poles supporting #4 AWG copper, 397.5 kcmil ACSR, and 954 kcmil ACSR primary conductors on the 26 kV primary distribution system.

Requirements for vertical spacing and hardware, and installation instructions to connect the primary conductor to the pole are included.

Criteria for pole top assemblies covered under this standard include the following:

Grade of construction	B or C
Pole class	1 or stronger
Pole length	50 ft
Soil condition	Average
Allowable line angle	0°–7°

For line angles greater than the allowable line angle described above, refer to SCL 0123.03.

Composite, steel, laminated, and other non-wood poles are outside the scope of this standard.

2. Application

This standard provides direction to Seattle City Light (SCL) engineers, crews, and contractors for the installation of two- and three-phase tangent pole top assemblies on 26 kV distribution poles with primary conductors.

3. General Requirements

Two-phase tangent poles shall be constructed as three-phase tangent poles without the center phase.

Three-phase tangent poles shall be constructed as shown in Table 3. All spans greater than 200 ft shall be designed by the engineer.





Table 3. Three-Phase Tangent Pole Top Assemblies

Conductor Size	Grade of Construction	Pole Class	Allowable Line Angle	Figures
#4 AWG	C	1	0°-7°	3a, 3c
#4 AWG	B	1	0°-1°	3b, 3c
397.5 kcmil	C	1	0°-4°	3d, 3g
397.5 kcmil	B	1	0°-1°	3f, 3g
954 kcmil	C	1	0°-3°	3e, 3g
954 kcmil	B	H1	0°-1°	3f, 3g

Figure 3a. Allowable Line Angle Range for Grade C #4 AWG Copper Tangent Pole

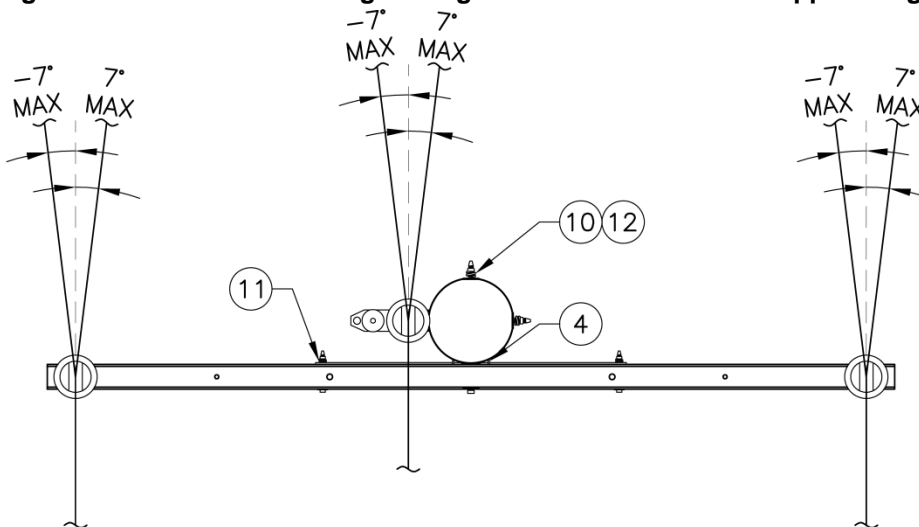

Figure 3b. Allowable Line Angle Range for Grade B #4 AWG Copper Tangent Pole

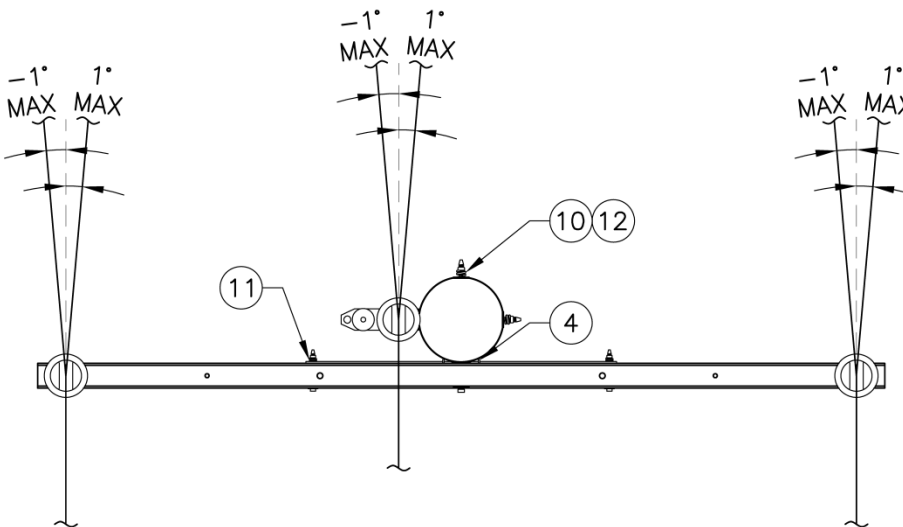

Figure 3c. Three-Phase #4 AWG Copper Tangent Pole Top Assemblies

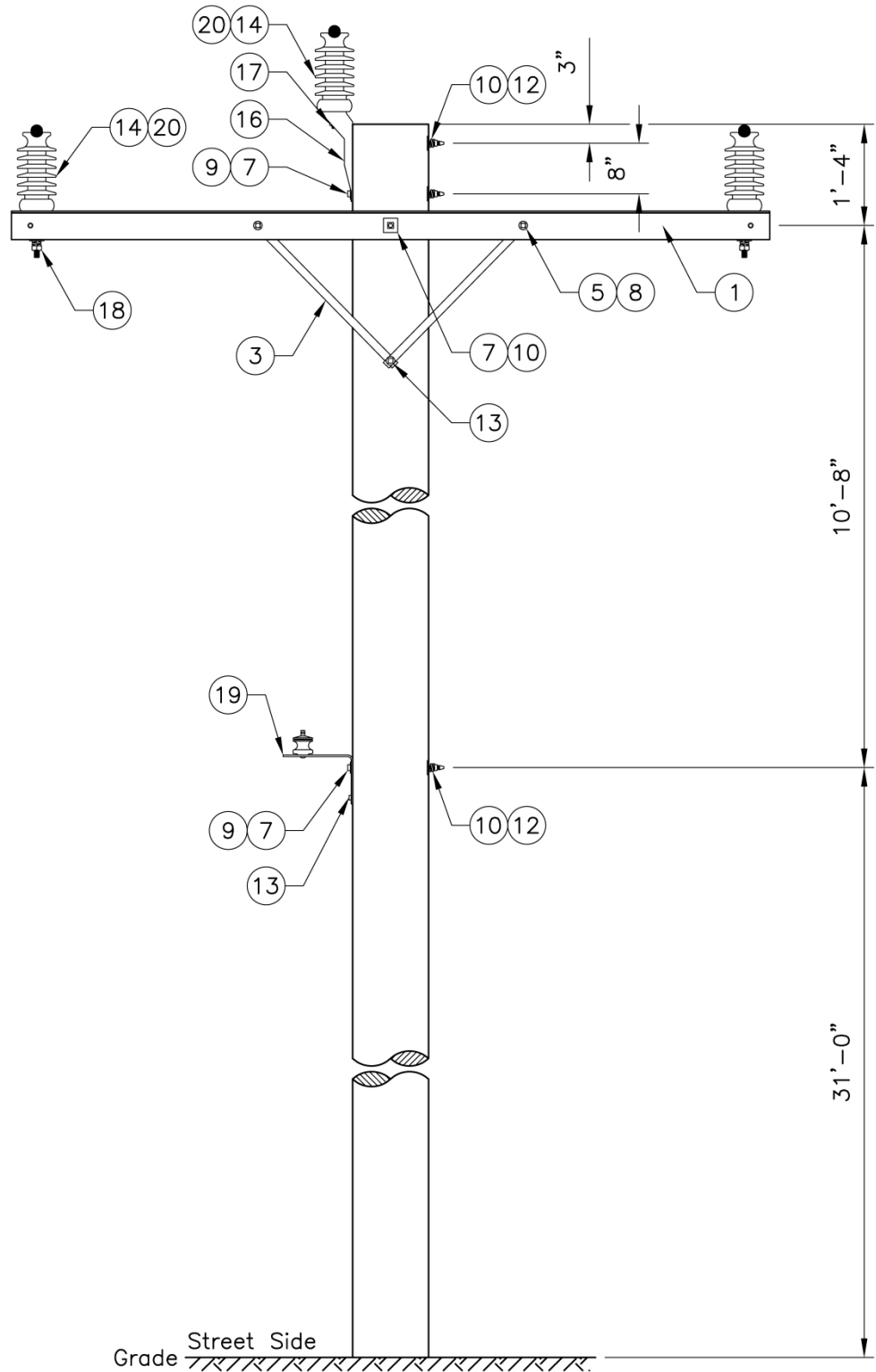

Figure 3d. Allowable Line Angle Range for Grade C 397.5 kcmil ACSR Tangent Pole

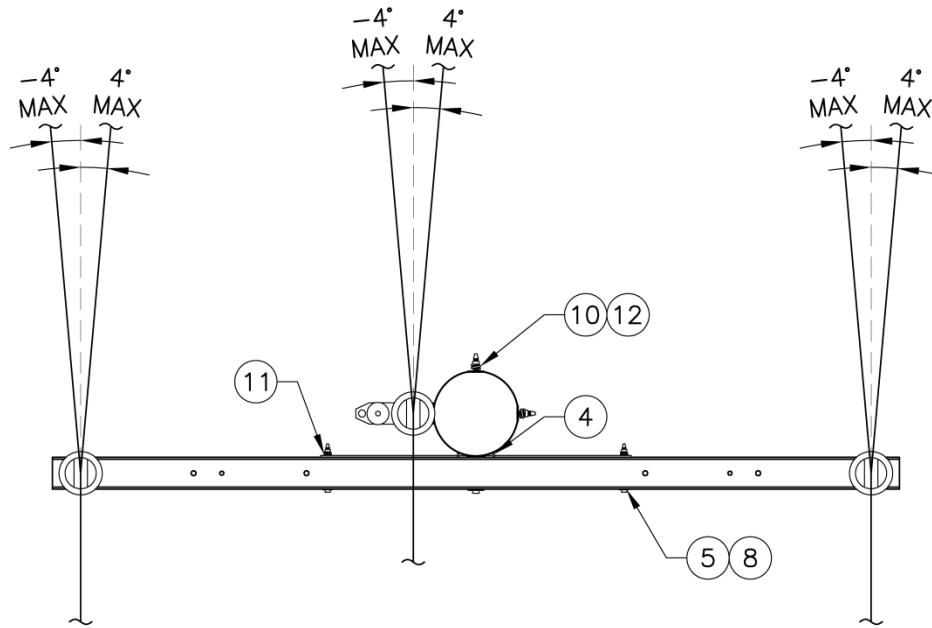

Figure 3e. Allowable Line Angle Range for Grade C 954 kcmil ACSR Tangent Pole

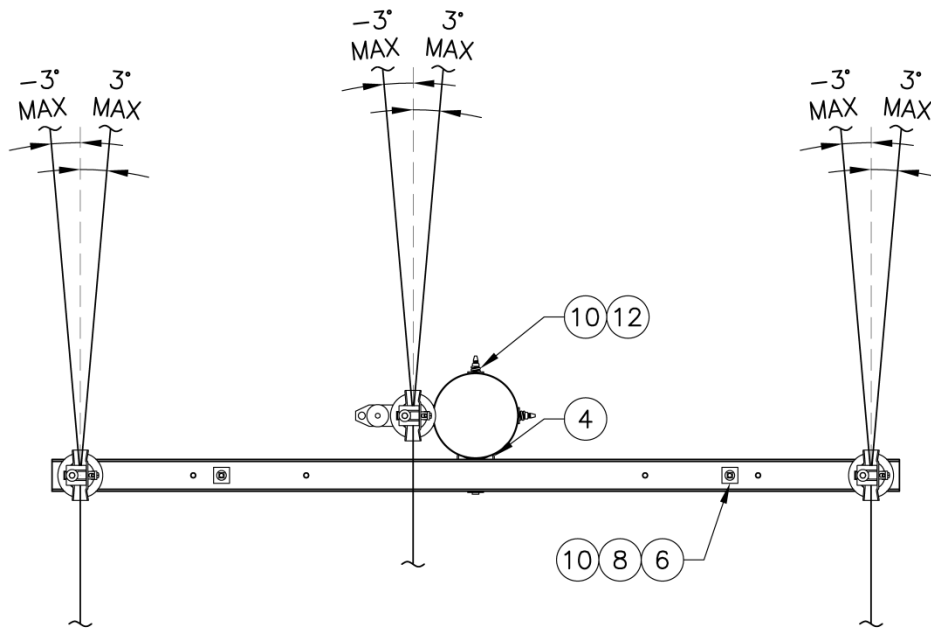

Figure 3f. Allowable Line Angle Range for Grade B 397.5 and 954 kcmil ACSR Tangent Poles

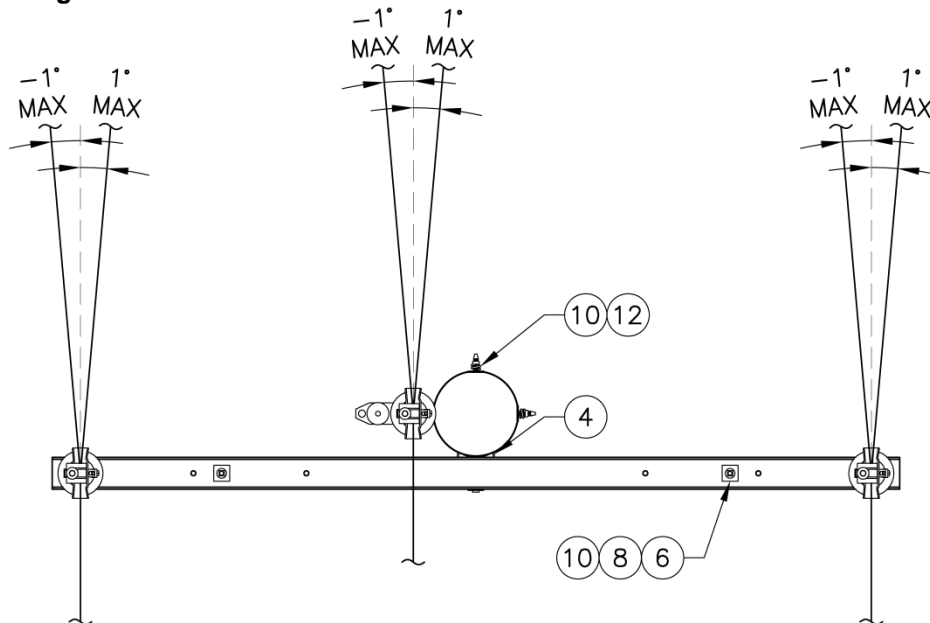
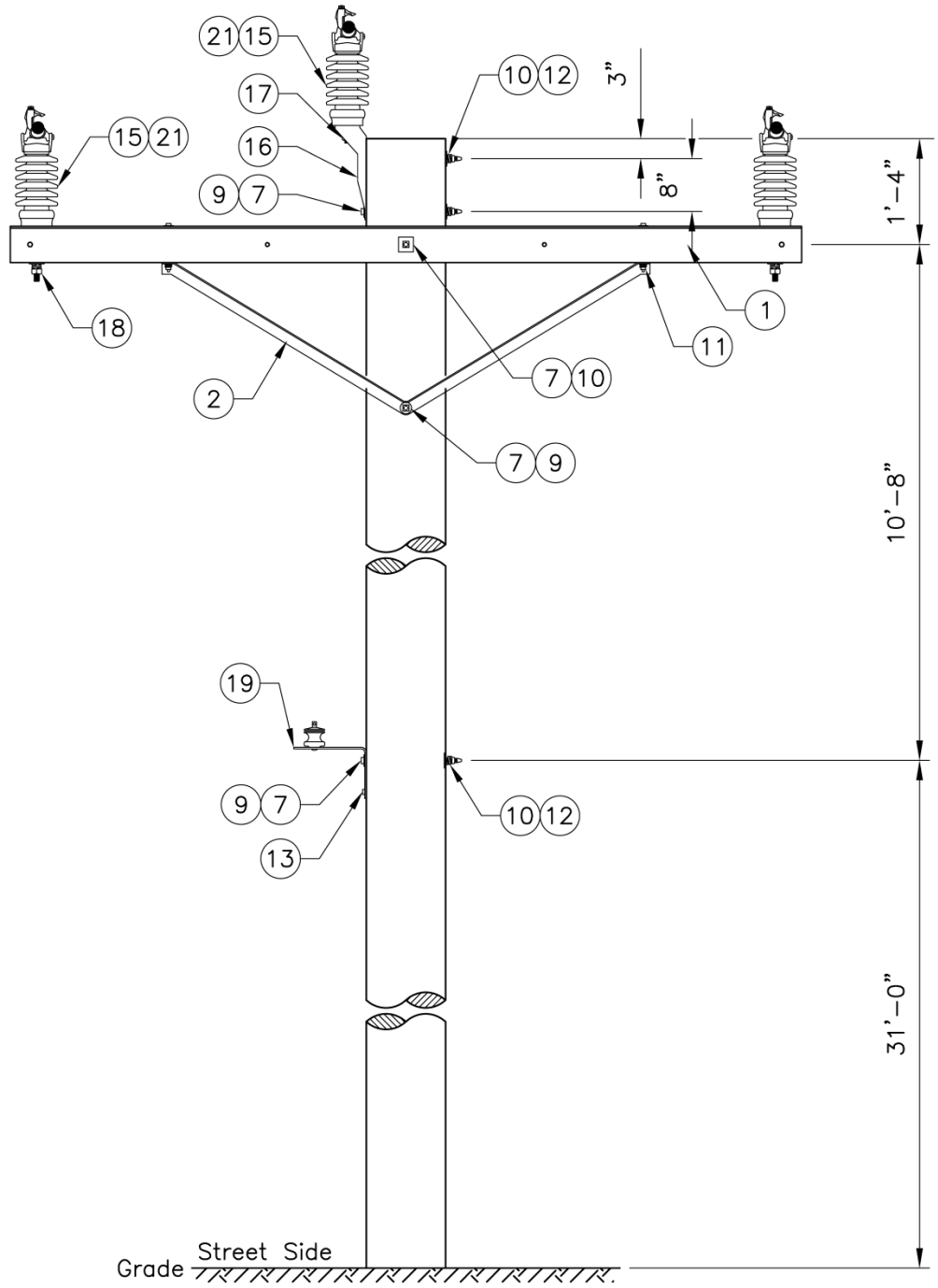

Figure 3g. Three-Phase 397.5 and 954 kcmil ACSR Tangent Pole Top Assemblies



4. Construction Notes

The headpin and LR bracket are installed on the street side of the pole.

If two neutrals are required, mount the second neutral on the street side 1 ft below the top bolt hole of the original neutral.

If poor soil is found in the field, contact the SCL Design Engineer.

If there are avian and wildlife concerns, contact the SCL Design Engineer.

If there are salt spray concerns, contact the SCL Design Engineer.

5. Material List

Table 5. Materials for Three-Phase Tangent Pole Top Assemblies

Fig	Compatible Unit	ID	Quantity			
3c	Three-phase #4 AWG copper tangent pole top assembly	PLT#4-3TANHP				
3g	Three-phase 397.5 kcmil ACSR tangent pole top assembly	PLT397-TANHP				
3g	Three-phase 954 kcmil ACSR tangent pole top assembly	PLT954-TANHP				
3c	Two-phase #4 AWG Cu tangent pole top assembly	PLT#4-2TAN				
#	Material Description	ID				
1	Crossarm, 8 pin, 10'	540220	1	-	-	1
1	Crossarm, 6 pin, 10'	540146	-	1	1	-
2	Crossarm, brace, V	563010	-	1	-	-
3	Crossarm, brace, flat, 32"	563005	2	-	2	2
4	Gain plate	565313	1	1	1	1
5	Bolt, machine, galvanized, 1/2" x 5"	780804	2	-	-	2
5	Bolt, machine, galvanized, 1/2" x 6"	780806	-	-	2	-
6	Bolt, machine, galvanized, 1/2" x 7"	780808	-	2	-	-
7	Bolt, machine, galvanized, 5/8" x 14"	780846	2	4	3	4
7	Bolt, machine, galvanized, 5/8" x 16"	780847	-	1	1	-
8	Washer, round, flat, 1/2"	585025	2	2	2	2
9	Washer, round, flat, 5/8"	585030	1	4	3	3
10	Washer, square, flat, 2-1/4" x 2-1/4"	585135	3	8	5	5
11	Washer, spring, 1/2"	584257	2	2	2	2
12	Washer, spring, 5/8"	584261	2	5	4	4
13	Screw, lag, 1/2" x 4"	785261	2	1	2	2
14	Insulator, post top, 34.5 kV, tie top	014304	2	-	-	3
15	Insulator, post top, 34.5 kV - clamp top	690159	-	3	3	-
16	Bracket, pole top	563253	-	1	1	1
17	Stud, short, 3/4" x 1-3/4"	696826	-	1	1	1
18	Stud, long, 3/4" x 7-1/2"	696828	2	2	2	2
19	Bracket, LR	690404	1	1	1	1
20	Wire tie, insulator, #6 Cu solid, bare, SD (ft)	610210	6	-	-	9
21	Clamp, trunnion, line post, 0.5"-1.06"	695193	-	-	3	-
21	Clamp, trunnion, line post, 0.99"-1.5"	695196	-	3	-	-

6. References

- SCL Construction Standard 0199.01**; “Requirements for Guying and Anchoring”
SCL Construction Standard 0123.03; “Three-Phase Angle Pole Top Assemblies”
-

7. Sources

- National Electrical Safety Code (NEC) C2-2012 Edition**; Institute of Electrical and Electronics Engineers (IEEE) Inc., New York, NY, 2011
- Hall, Alan**; SCL Senior Electrical Engineer and subject matter expert for 0123.01 (alan.hall@seattle.gov)
- Lu, Curtis**; SCL Standards Engineer and originator of 0123.01 (curtis.lu@seattle.gov)