

Three-Phase Deadend Pole Top Assemblies for View Areas**1. Scope**

This standard covers the information necessary to construct pole top assemblies for three-phase deadend poles in view areas (view poles) supporting #4 AWG copper primary conductors on the 26 kV primary distribution system. Requirements for vertical spacing and hardware, and installation instructions to connect the primary conductor to the pole are included.

Criteria for pole top assemblies covered under this standard include the following:

Grade of construction	C Only
Pole class	1 or Stronger
Pole length	50 ft
Soil condition	Average
Allowable line angle	0°–60°

If a deadend is not required, refer to SCL 0103.01 and SCL 0103.03.

For line angles greater than the allowable line angle described above, contact the SCL Engineer.

Composite, steel, laminated and other non-wood poles are outside the scope of this standard.

2. Application

This standard provides direction to Seattle City Light (SCL) engineers, crews and contractors for the installation of three-phase deadend pole top assemblies in view areas on 26 kV distribution poles with #4 AWG copper primary conductors.

3. Requirements

View poles shall only be installed with the authorization of SCL Engineering management. The typical use for a view pole is for locations with a view obstruction problem.

The three-phase single deadend view pole shall be constructed as shown in figures 3a and 3b.

The single deadend view pole shall have the crossarms perpendicular to the primary conductor.

The allowable line angle for a three-phase double deadend view pole is between 0 and 60 degrees as shown in Figure 3c and shall be constructed as shown in Figure 3d.

For a 50-ft pole in average soils, embed 7 ft in the ground and cut 7 ft off the top of the pole.





Any single crossarm shall be installed on the side opposite of the face of the pole.

Any equipment in the power supply space shall be installed on the face of the pole.

Deadend poles shall be guyed according to the requirements of SCL 0199.01.

The highest communication attachment shall be located at a minimum of 40 in below the secondary and neutral and a minimum of 10 ft below the top of the transformer.

Only two communication attachments at 21 ft and 22 ft are allowed on a view pole.

Figure 3a. Three-Phase Single Deadend Pole Top Assembly for View Areas, Top View

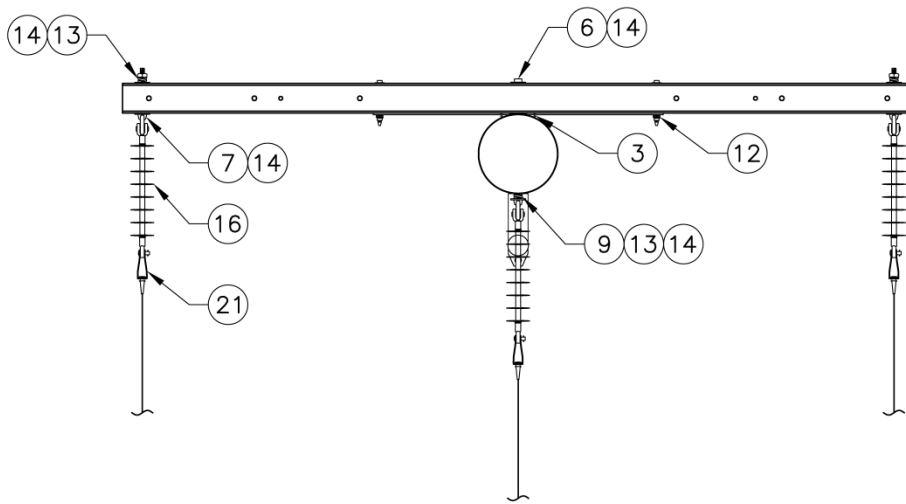

Figure 3b. Three-Phase Single Deadend Pole Top Assembly for View Areas, Side View

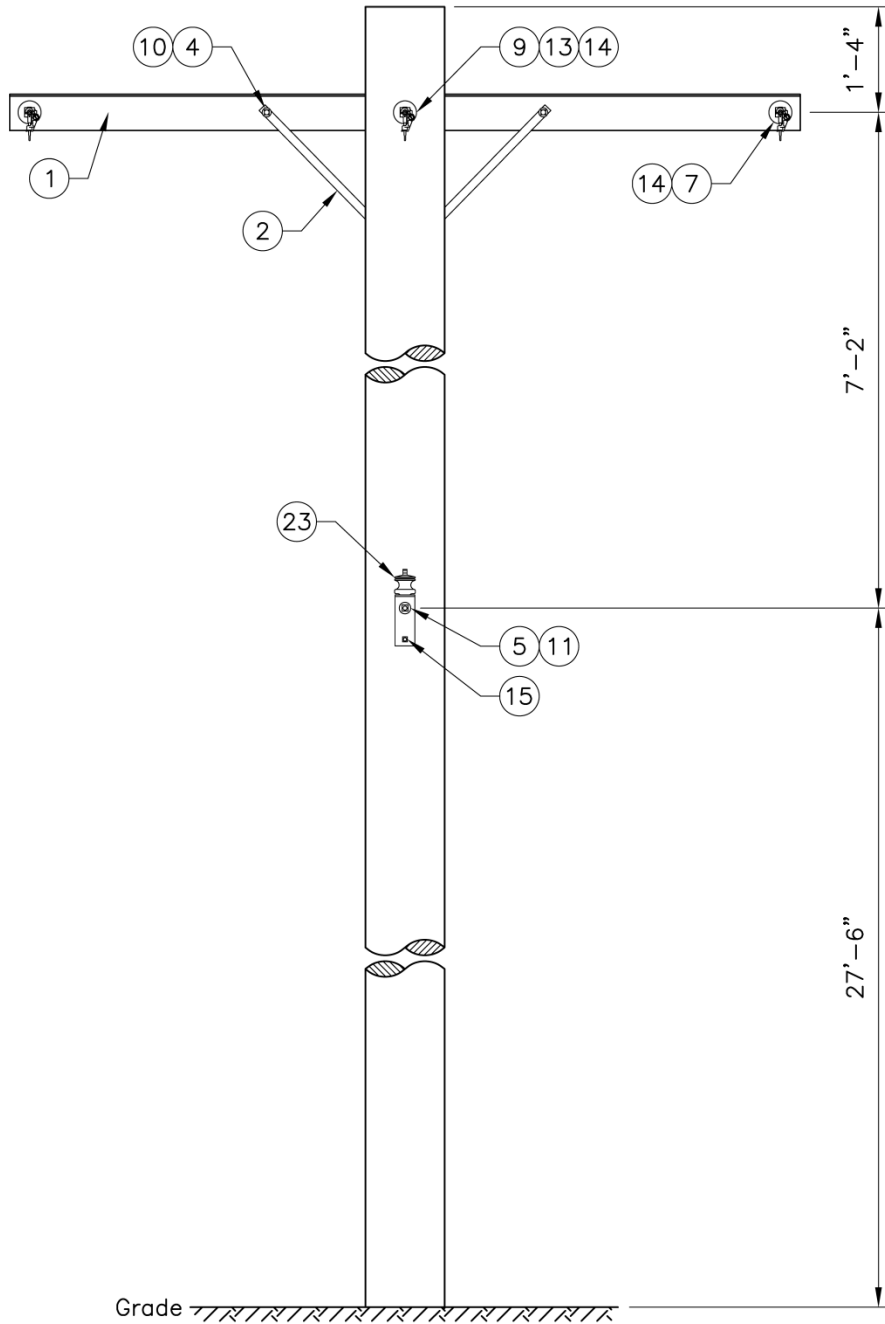

Figure 3c. Allowable Line Angle Range for Double Deadend View Pole

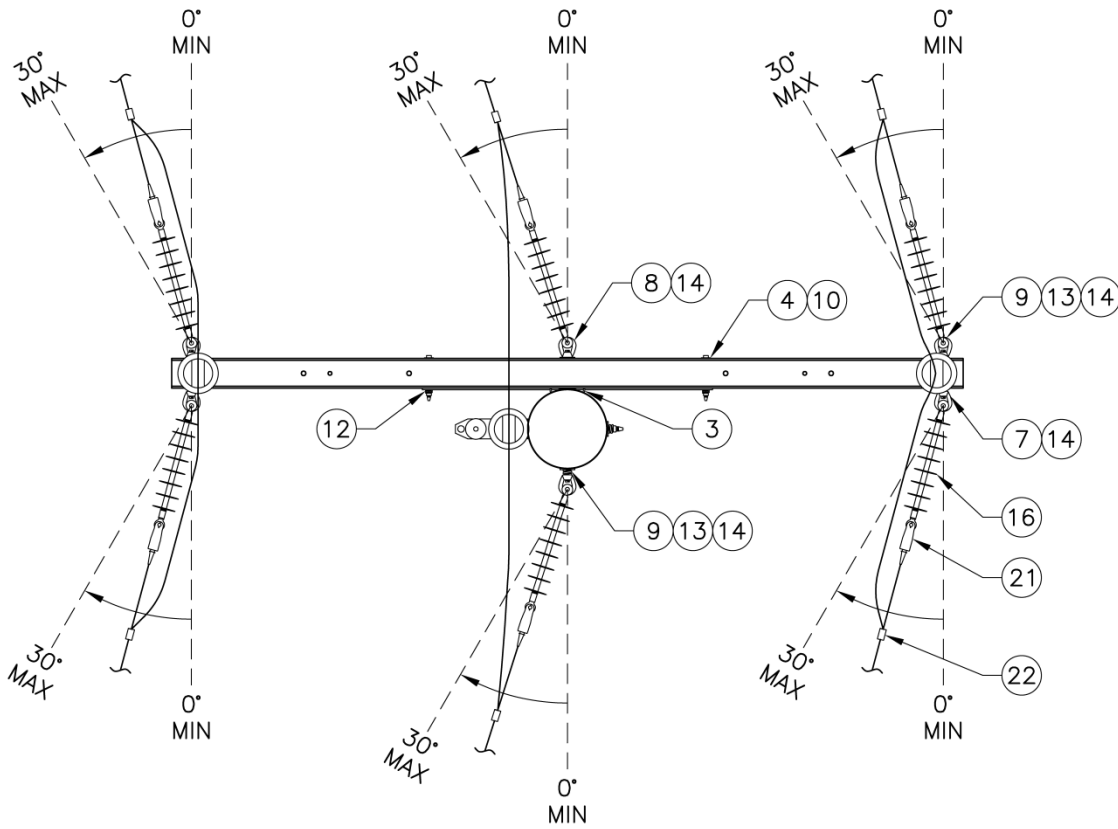
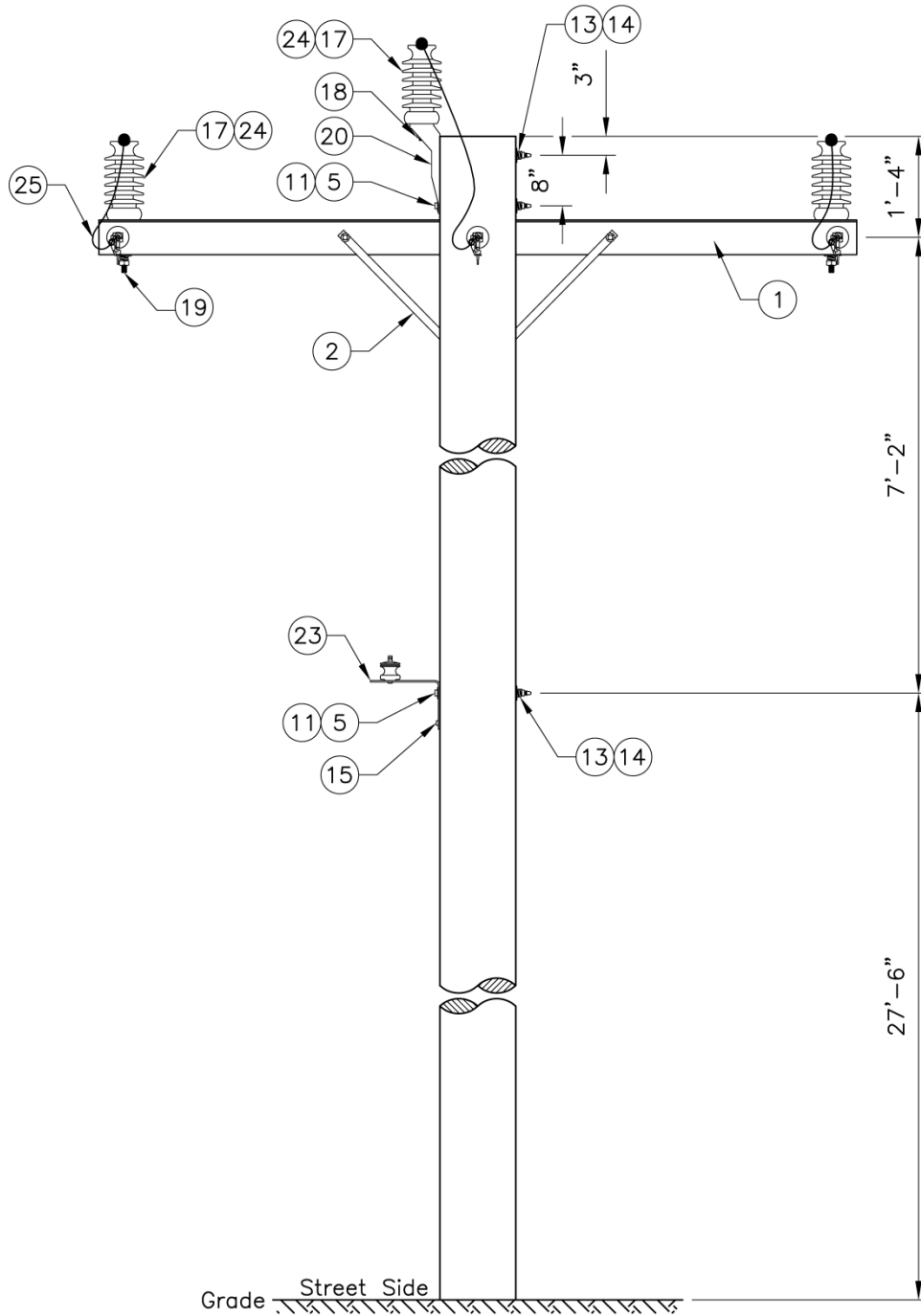

Figure 3d. Three-Phase Double Deadend Pole Top Assembly for View Areas



4. Construction Notes

If two neutrals are required, mount the second neutral on the street side 1 ft below the top bolt hole of the original neutral.

If poor soil is found in the field, contact the SCL Design Engineer.

If there are avian and wildlife concerns, contact the SCL Design Engineer.

If there are salt spray concerns, contact the SCL Design Engineer.

5. Material Lists

Table 5. Materials for Three-Phase Deadend Pole Top Assemblies for View Areas

Fig	Compatible Unit	ID	Quantity	
3b	Three-phase single deadend view pole	PLT#4-3DEVW		
3d	Three-phase double deadend view pole	PLT#4-3DDEHPVW		
#	Material Description	ID		
1	Crossarm, wood, 6 pin, 10'	540146	1	1
2	Crossarm brace, flat, 32"	563005	2	2
3	Gain, plate	565313	1	1
4	Bolt, machine, galvanized, 1/2" x 6"	780806	2	2
5	Bolt, machine, galvanized, 5/8" x 14"	780846	3	1
6	Bolt, machine, galvanized, 5/8" x 16"	780847	-	1
7	Bolt, oval eye, galvanized, 5/8" x 6"	561106	2	2
8	Bolt, oval eye, galvanized, 5/8" x 16"	561116	1	-
9	Nut, eye, 5/8"	565252	3	1
10	Washer, round, flat, 1/2"	585025	2	2
11	Washer, round, flat, 5/8"	585030	3	1
12	Washer, spring, 1/2"	584257	2	2
13	Washer, spring, 5/8"	584261	6	4
14	Washer, square, flat, 2-1/4" x 2-1/4"	585135	9	7
15	Screw, lag, 1/2" x 4"	785261	2	2
16	Insulator, deadend, polymer, 20"	690233	6	3
17	Insulator, post top, 34.5 kV	690157	3	-
18	Stud, short, 3/4" x 1-3/4"	696826	1	-
19	Stud, long, 3/4" x 7-1/2"	696828	2	-
20	Bracket, pole top	563253	1	-
21	Deadend, automatic, feed through, #4 AWG	581332	6	3
22	Clamp, hot line tap, 2/0 to #8 AWG	580725	6	-
23	Bracket, LR	690404	1	1
24	Wire, insulator tie, #6 AWG Cu, solid, SD (ft)	610210	9	-
25	Wire, jumper, #4 AWG Cu, solid, bare, SD (ft)	610208	25	-

6. References

SCL Construction Standard 0199.01; “Requirements for Guying and Anchoring”

SCL Construction Standard 0103.01; “Three-Phase Tangent Pole Top Assembly for View Areas”

SCL Construction Standard 0103.03; “Three-Phase Angle Pole Top Assembly for View Areas”

7. Sources

National Electrical Safety Code (NESC); C2-2012 Edition; Institute of Electrical and Electronics Engineers (IEEE) Inc., New York, NY, 2011

Hall, Alan; SCL Senior Electrical Engineer and subject matter expert for 0103.05 (alan.hall@seattle.gov)

Lu, Curtis; SCL Standards Engineer and originator of 0103.05 (curtis.lu@seattle.gov)