

Three-Phase Tangent Pole Top Assembly for View Areas

1. Scope

This standard covers the information necessary to construct the pole top assembly for three-phase tangent poles in view areas (view poles) supporting #4 AWG copper primary conductors on the 26 kV primary distribution system. Requirements for vertical spacing and hardware, and installation instructions to connect the primary conductor to the pole are included.

Criteria for the pole top assembly covered under this standard include the following:

Grade of construction	C only
Pole class	1 or stronger
Pole length	50 ft
Soil condition	Average
Allowable line angle	0°–7°

For line angles greater than the allowable line angle described above, refer to SCL 0103.03.

Composite, steel, laminated, and other non-wood poles are outside the scope of this standard.

2. Application

This standard provides direction to Seattle City Light (SCL) engineers, crews, and contractors for the installation of a three-phase tangent pole top assembly in view areas on 26 kV distribution poles with #4 AWG copper primary conductors.

3. General Requirements

View poles shall only be installed with the authorization of SCL Engineering management. View poles are typically used for locations with a view obstruction problem.

The allowable line angle for a three-phase tangent view pole is between 0 and 7 degrees as shown in Figure 3a. The pole shall be constructed as shown in Figure 3b.

In average soils, a 50-ft pole shall be embedded 7 ft in the ground. Once set, 7 ft shall be cut off the top of the pole.

Single crossarms shall be installed on the side opposite of the face of the pole.

Equipment in the power supply space shall be installed on the face of the pole.

The highest communication attachment shall be located at a minimum of 40 in below the secondary and neutral and a minimum of 10 ft below the top of the transformer.

Only two communication attachments at 21 ft and 22 ft are allowed on a view pole.





Figure 3a. Allowable Line Angle Range

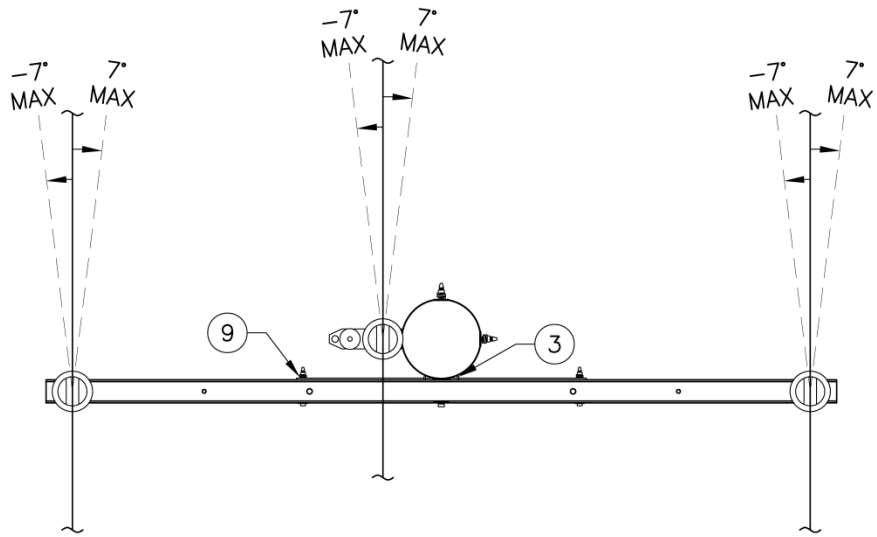
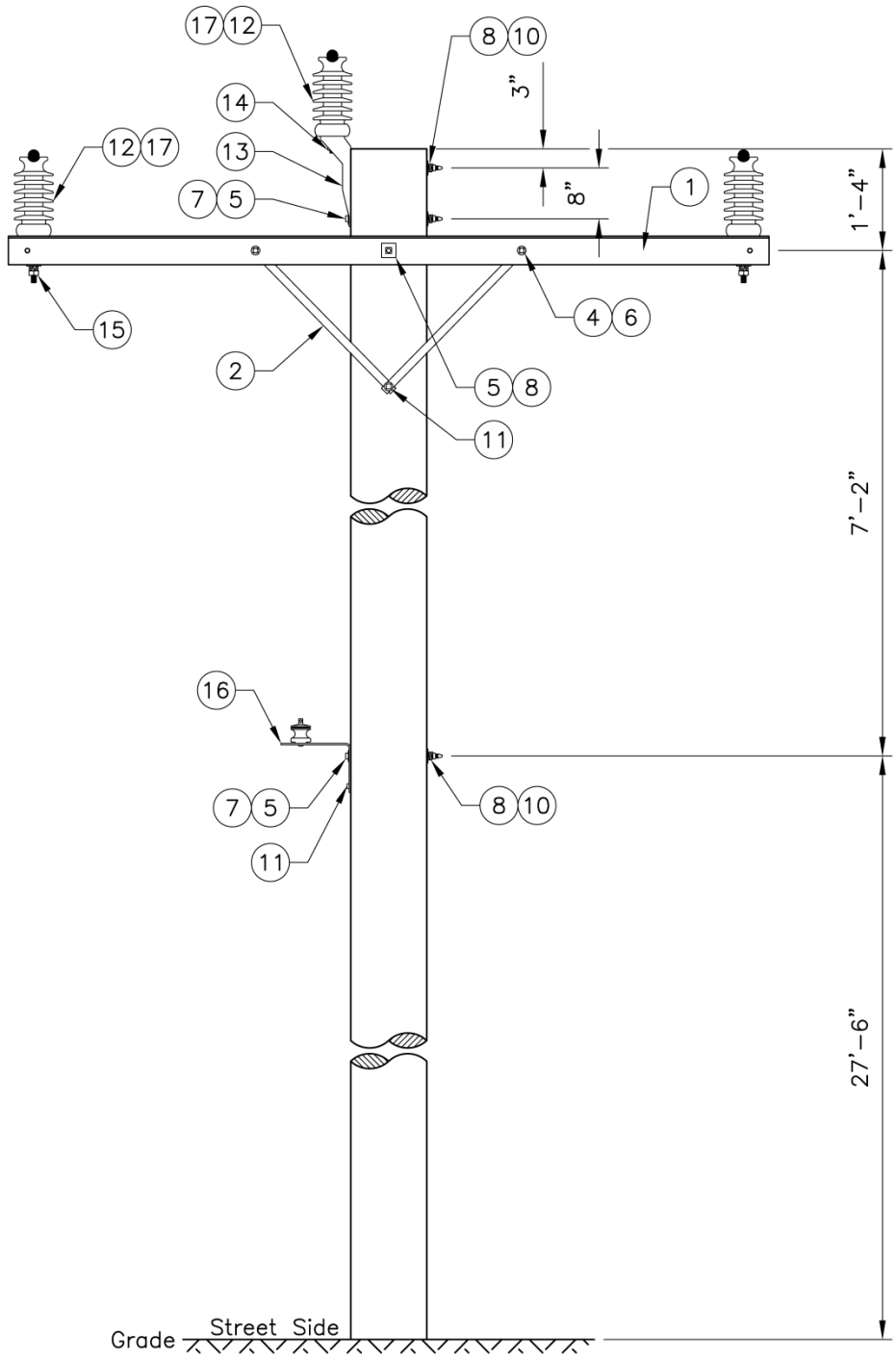

Figure 3b. Three-Phase Tangent Pole Top Assembly for View Areas



4. Construction Notes

- The headpin and LR bracket are installed on the street side of the pole.
- If two neutrals are required, mount the second neutral on the street side 1 ft below the top bolt hole of the original neutral.
- If poor soil is found in the field, contact the SCL Design Engineer.
- If there are avian and wildlife concerns, contact the SCL Design Engineer.
- If there are salt spray concerns, contact the SCL Design Engineer.

5. Material List

Table 5a. Materials for Three-Phase Tangent Pole Top Assembly for View Areas

Fig	Compatible Unit	ID	Qty
3b	Three-Phase Tangent View Pole	PLT#4-3TANHPVW	↓
#	Material Description	ID	
1	Crossarm, 8 pin, 10'	540220	1
2	Crossarm brace, flat, 32"	563005	2
3	Gain plate	565313	1
4	Bolt, machine, galvanized, 1/2" x 5"	780804	2
5	Bolt, machine, galvanized, 5/8" x 14"	780846	4
6	Washer, round, flat, 1/2"	585025	2
7	Washer, round, flat, 5/8"	585030	3
8	Washer, square, flat, 2-1/4" x 2-1/4"	585135	5
9	Washer, coil spring, 1/2"	584257	2
10	Washer, coil spring, 5/8"	584261	4
11	Screw, lag, 1/2" x 4"	785261	2
12	Insulator, post top, 34.5 kV	690157	3
13	Bracket, pole top	563253	1
14	Stud, short, 3/4" x 1-3/4"	696826	1
15	Stud, long, 3/4" x 7-1/2"	696828	2
16	LR bracket	690404	1
17	Wire, tie, insulator, #6 SD solid Cu (ft)	610210	9

6. References

SCL Construction Standard 0103.03; "Three-Phase Angle Pole Top Assembly for View Areas"

7. Sources

National Electrical Safety Code (NESC) C2-2012 Edition; Institute of Electrical and Electronics Engineers (IEEE) Inc., New York, NY, 2011

Hall, Alan; SCL Senior Electrical Engineer and subject matter expert for 0103.01 (alan.hall@seattle.gov)

Lu, Curtis; SCL Standards Engineer and originator of 0103.01 (curtis.lu@seattle.gov)