

---

## Single-Phase Angle Pole Top Assembly for View Areas

---

### 1. Scope

This standard covers the information necessary to construct the pole top assembly for single-phase angle poles in view areas (view poles) supporting #4 AWG copper primary conductors on the 26 kV primary distribution system. Requirements for vertical spacing and hardware, and installation instructions to connect the primary conductor to the pole are included.

Criteria for the pole top assembly covered under this standard include the following:

<b>Grade of construction</b>	C only
<b>Pole class</b>	3 or stronger
<b>Pole length</b>	50 ft
<b>Soil condition</b>	Average
<b>Allowable line angle</b>	8°–30°

For line angles less than the allowable line angle described above, refer to SCL 0101.01.

For line angles greater than the allowable line angle described above, refer to SCL 0101.05.

Composite, steel, laminated, and other non-wood poles are outside the scope of this standard.

---

### 2. Application

This standard provides direction to Seattle City Light (SCL) engineers, crews and contractors for the installation of a single-phase angle pole top assembly in view areas on 26 kV distribution poles with #4 AWG copper primary conductors.

---

### 3. General Requirements

View poles shall only be installed with the authorization of SCL Engineering management. The typical use for a view pole is for locations with a view obstruction problem.

The allowable line angle for a single-phase angle view pole is between 8 and 30 degrees as shown in Figure 3a and shall be constructed as shown in Figure 3b.

A side tie shall be used for an angle pole and be installed on the side of the insulator away from the pole. The headpin on an angle pole shall be installed on the side of the pole where the conductor angles into the pole.

In average soils, install a 50-ft pole embedded 7 ft in the ground. Once set, cut 7 ft off the top of the pole. The angle pole shall be guyed according to the requirements of SCL 0199.01.

The highest communication attachment shall be located at a minimum of 40 in below the secondary and neutral and a minimum of 10 ft below the top of the transformer.





Only two communication attachments at 21 ft and 22 ft are allowed on a view pole.

**Figure 3a. Allowable Line Angle Range**

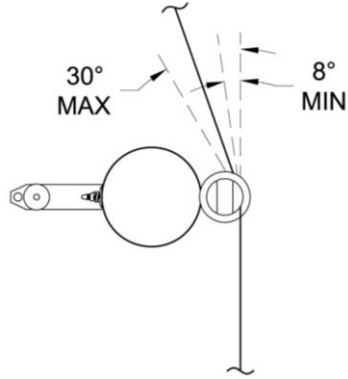

**Figure 3b. Single-Phase Angle Pole Top Assembly for View Areas**

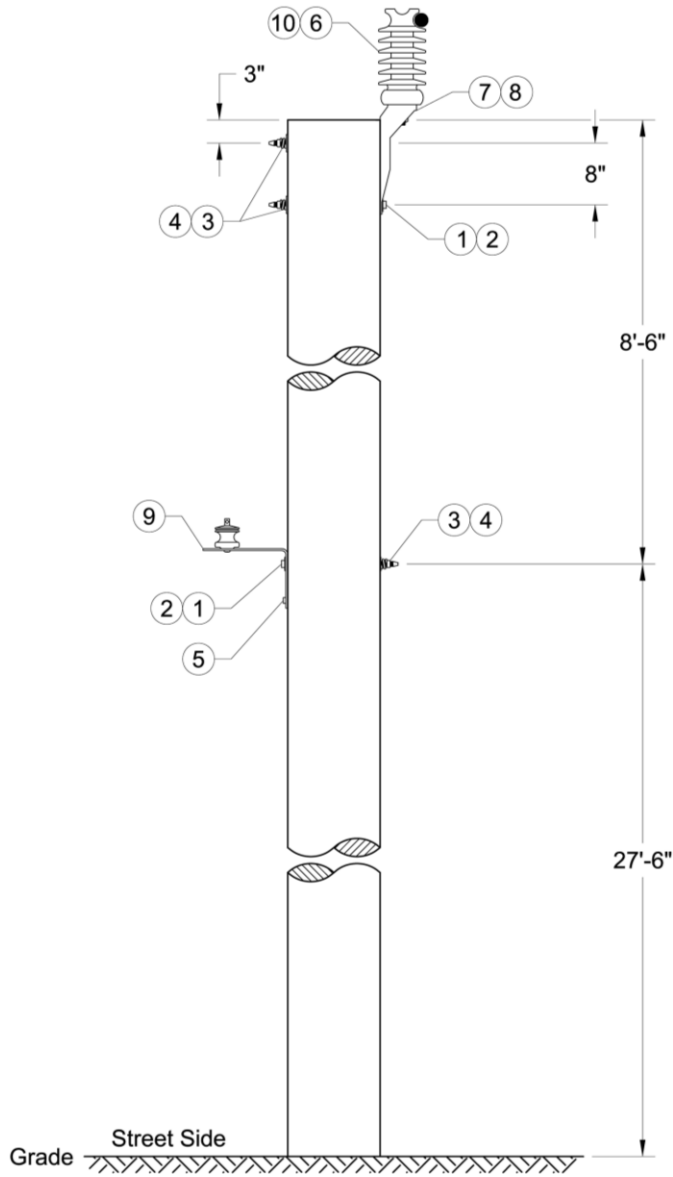

#### 4. Construction Notes

- The LR bracket is installed on the street side of the pole.
- If two neutrals are required, mount the second neutral on the street side 1 ft below the top bolt hole of the original neutral.
- If poor soil is found in the field, contact the SCL Design Engineer.
- If there are avian and wildlife concerns, contact the SCL Design Engineer.
- If there are salt spray concerns, contact the SCL Design Engineer.

#### 5. Material List

**Table 5. Materials for Single-Phase #4 AWG Copper Angle Pole Top Assembly for View Areas**

Fig	Compatible Unit	ID	Qty
3b	Single-phase #4 AWG angle, 8°–30°, view	PLT#4-1ANGHPVW	↓
#	Material Description	ID	
1	Bolt, machine, galvanized, 5/8" x 14"	780846	3
2	Washer, round, flat, 5/8"	585030	3
3	Washer, square, flat, 2-1/4" x 2-1/4"	585135	3
4	Washer, spring, 5/8"	584261	3
5	Screw, lag, 1/2" x 4"	785261	1
6	Insulator, post top 34.5 kV	690157	1
7	Stud, short	696826	1
8	Bracket, pole top	563253	1
9	LR bracket	690404	1
10	Wire, tie, insulator, #6 AWG Solid Cu SD (ft)	610210	3

#### 6. References

- SCL Construction Standard 0199.01**; “Requirements for Guying and Anchoring”
- SCL Construction Standard 0101.01**; “Single-Phase Tangent Pole Top Assembly For View Areas”
- SCL Construction Standard 0101.05**; “Single-Phase Dead End Pole Top Assembly for View Areas”

#### 7. Sources

- Hall, Alan**; SCL Engineer and subject matter expert for 0101.03 (alan.hall@seattle.gov)
- Lu, Curtis**; SCL Standards Engineer and originator of 0101.03 (curtis.lu@seattle.gov)
- National Electrical Safety Code (NESC); C2-2012 Edition**; Institute of Electrical and Electronics Engineers (IEEE) Inc., New York, NY, 2011