



4709 ROOSEVELT WAY NE

SDCI # 3038322-EG | MUP # 3036766-LU

EARLY DESIGN GUIDANCE MEETING #2

07.18.2022

PROJECT INFORMATION:

ADDRESS: 4709 ROOSEVELT WAY NE
Seattle, WA 98105

LEGAL DESCRIPTION: MCGUIRE & HOLDENS TO
LATONA SUPL
PLAT BLOCK :1 PLAT LOT:17
THRU 21

PARCEL NUMBER: 533520-0115

ZONING: NC3-65
SITE AREA 11,313 SF
FAR 4.5
MAX HEIGHT 65'

PROJECT TEAM:

OWNER: ONELIN Capital Corporation
601 Union St. Suite 1730
Seattle, WA 98101
206.550.1538
Contact: Brittney Brandt

ARCHITECT: HEWITT
101 Stewart Street, Suite 200
Seattle, WA 98101
206.624.8154
Contact: Sean Ludviksen, Principal

LANDSCAPE ARCHITECT: Karen Kiest Landscape Architects
111 West John ST, Suite 306
Seattle, WA 98119
206.323.6032
Contact: Karen Kiest

01
PROJECT OBJECTIVES AND BACKGROUND | 4-16

02
SITE CONTEXT | 17-27

03
EXISTING SITE | 28-29

04
ZONING | 30-34

05
DESIGN GUIDELINES | 35-37

06
PREVIOUS ALTERNATIVES | 38-39

07
EDG 1 BOARD DIRECTION | 40-42

08
EDG 2 RESPONSE | 43-45

09
SITE CONTEXT & ANALYSIS | 46-48

10
MASSING + FACADE CONCEPT | 49-65

11
INTERIOR LOT LINE FACADE CONCEPT | 66-69

12
ZONE TRANSITION | 68-74

13
STREET LEVEL CONCEPT | 76-82

14
FLOOR PLANS | 83-87

15
ROOF LEVEL | 88-93

16
OVERALL EDG 2 VIEWS | 94-100

17
SUMMARY | 101-103

01 | PROJECT OBJECTIVES AND BACKGROUND

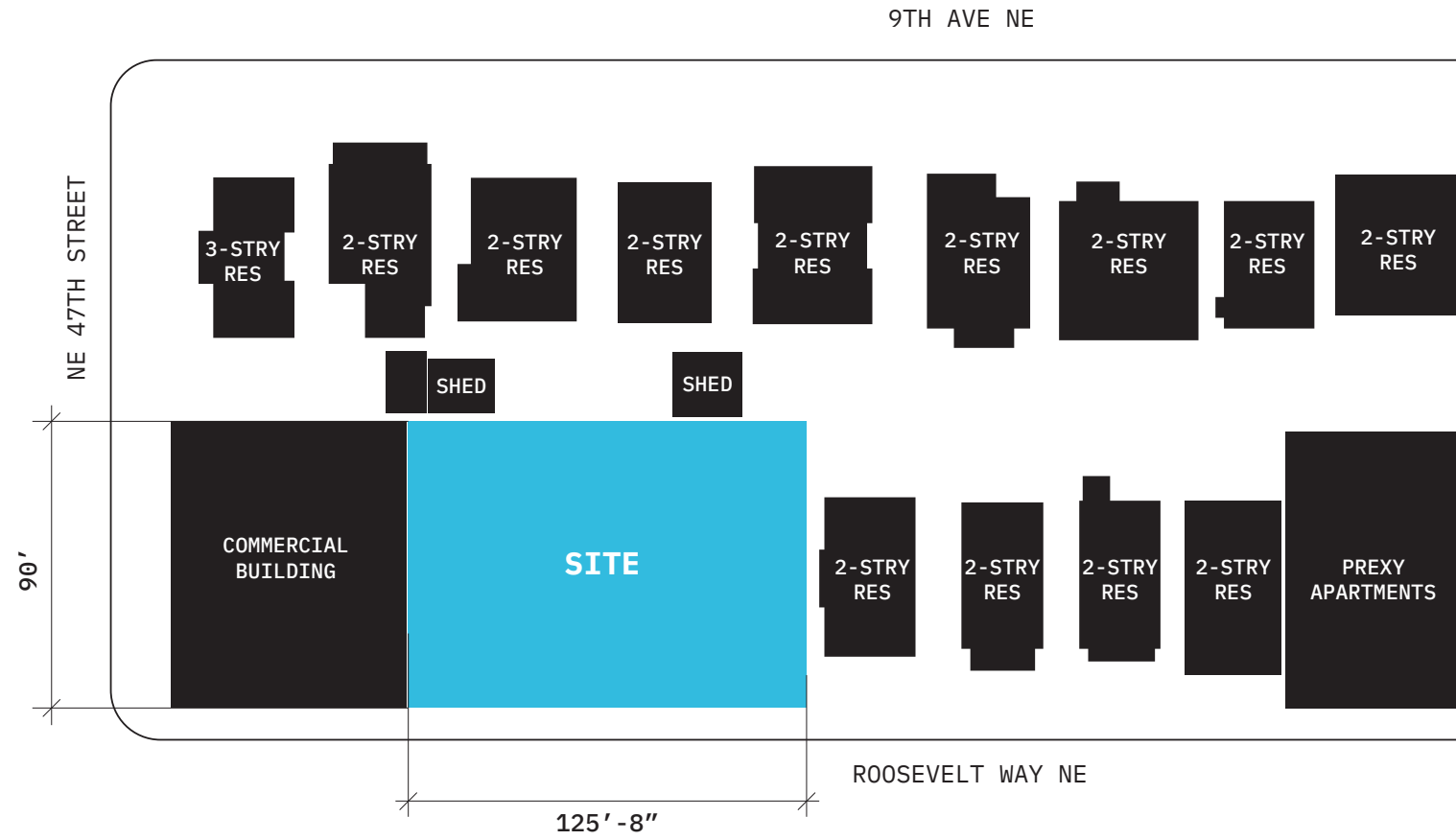

PROJECT QUANTITIES

- + 11,306 SF Site Area
- + 65' tall residential building + mechanical penthouse overrun
- + 7 stories + residential rooftop terrace
- + +/- 51,000 total SDCI GFA

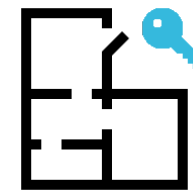

RESIDENTIAL UNITS

- + +/- 81 total units
- + Studio, Urban 1-Bed, 2-Bed units mix



STREET LEVEL USE

- + Potential street level retail kiosk conversion (+/- 350 SF)
- + Additional setback at Roosevelt Way NE



PARKING

- + No on site parking proposed.
- + 78 +/- Bike Parking spaces



DEPARTURE REQUESTS

- + No anticipated departures at this time.

PROJECT CONSIDERATIONS SUMMARY

• Introduction | Message to the Board.

We would like to begin by thanking the board members for volunteering their time to participate in the design review process with a common goal – to promote and foster good design.

While City's Design Review Process focuses on important considerations such as urban design and architectural cues, the pedestrian realm, height, bulk, and scale, it can be an incomplete set of factors for a successful process. Therefore, as additional reference to facilitate your review and our future meetings, we'd like to highlight the development of the project, it's team and the design approach.

• Project Background Since the Early Design Guidance

Following the first Early Design Guidance meeting held on April 11, 2022, the project's ownership team made the decision to move the project forward with a change in the design team. Onelin Capital Corporation reached out to us to apply our mid-rise and University District neighborhood expertise on the project.

Hewitt-Architecture is currently working on two high-rise, mixed-use residential projects south the project site, along NE 45th Street. One located at 1013 NE 45th Street and the second, across the street at 1107 NE 45th Street. Both projects consider the indelible traits and characteristics of the neighborhood to form their design concepts. 1013 NE 45th Street is a 25-story, mixed-use residential tower named "OneU". The project recently presented the northeast board. The context and site analysis of the project characterized the University District Neighborhood as: "Rational and Romantic." This expression describes a rational north / south street grid juxtaposed with the urban design patterns of the University of Washington's Campus planning and natural features of the neighborhood such as Union and Portage Bay's water edge forming the route of the Burke-Gilman Trail and to the north, Ravenna Park. These neighborhood features have more organically formed and organized patterns we describe as "Romantic."



• Project Background Since the Early Design Guidance (continued)

Our second project, a 27-story, mixed-use residential tower located across the street from OneU at 1107 NE 45th Street. This project also considers the characteristics of the neighborhood. However, through the design team's study we focused on the differences between the site's located opposite from one another. Through our context and site analysis for the 1107 NE 45th Street site, we observed a slightly different set of urban conditions than at 1013 NE 45th Street. While 1013 NE 45th Street had adjacent neighbors unlikely to be redeveloped, it's south, west, and north immediate context was more open and unconstrained. With 1013 NE 45th street directly west of 1107 and with the potential for adjacent development around the site, the design team viewed the context at 1107 NE 45th Street as being more contained and localized with more "tower traffic" surrounding it. The design team made the decision to consider more localized aspects of the "rational and romantic" University District Neighborhood.

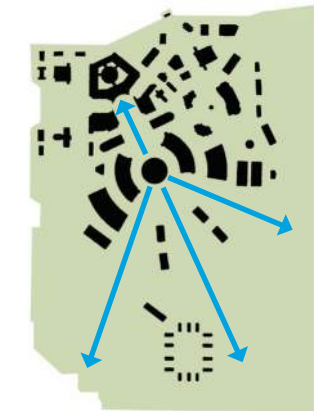
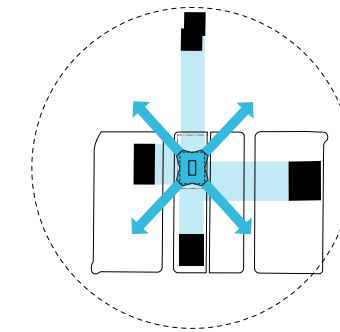

• Tall Buildings on Street Corners v. Mid-Rise Infill

The design team's previous work in the neighborhood are tall buildings. Tall buildings often consider multiple scales and have a different set of conditions regarding the site and context. A tower may have a context at its base scale relative to the street, the block, and pedestrian, while the upper portions of a tower might have a larger context and urban conditions that may inform the design approach of the tower differently than the street level. Towers can knit into a block and have a figural presence at the same time.

The site at 4709 Roosevelt Way NE is zoned for a low to mid-rise scale and is mid-block. An urban infill. The site is decidedly within the "rational" street grid. It is part of the "fabric" of the University District neighborhood.

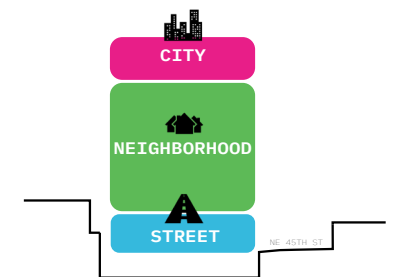

MESSAGE TO THE BOARD

• **Under-improved Block, and Future Considerations**

4709 Roosevelt Way NE is centered within a series of zoning transitions. To the east, across Roosevelt Way NE is a more intense SM-U 75-240 zone. The block which the project's site is located is split between an NC3 zone to the east and a LR2 zone to the west thus creating three layers of zoning stepping down to eventually an LR1 zone west of the project site's block. The block is currently under-improved when compared to the intentions of the City's zoning code. Currently there is one structure on the east side of the block that represents the expected development.

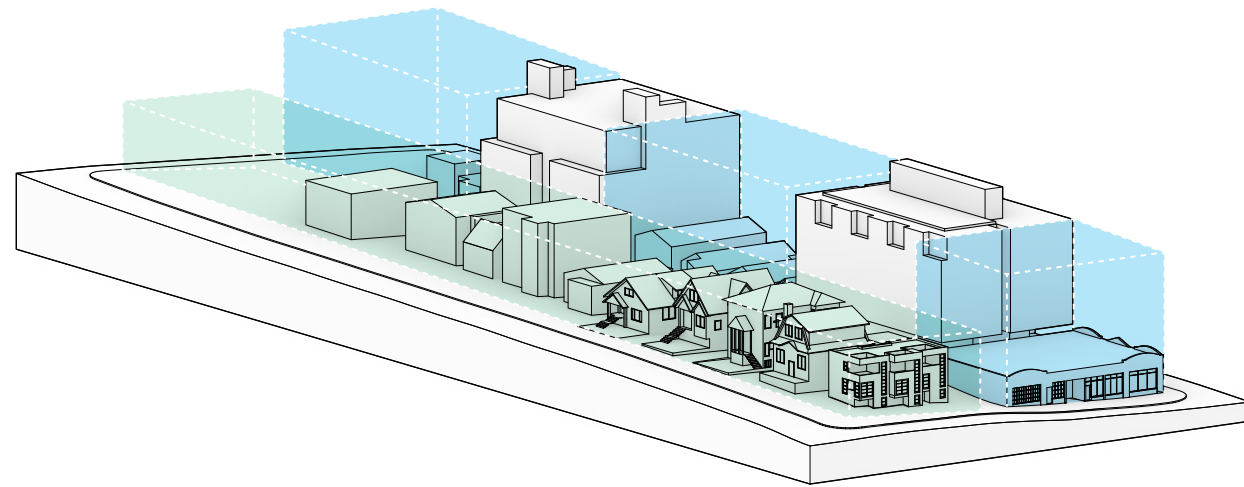

• **Urban Grain**

The differences in zoning intensity and types of development east and west of the site is also expressed in different urban grains. To the west of the site the original platting is divided into 30-foot-wide segments while the project site's block was originally divided into 25-foot-wide segments. (Closer to the commercial heart on the University District the blocks have 40-foot-wide lot divisions.) While parcels of land have been modified over time, platting patterns are expressed in existing structures and provide a basis for considering future development.



• **Urban Grain (cont.)**

This is also reflected in the University District Supplemental Guideline CS2-1-e Urban Pattern and Form. The proposal considered the historic platting patterns when reorganizing the proposal. It does so by:

Proposing a double loaded corridor plan arrangement divided into 30' wide column bays with apartment homes sub-divided into 15' widths. This 30' wide pattern bridges between the 30 foot-width platting across the street to the east, accommodates a contemporary multi-family structural system and unit expectations and along with a 9'-8" floor to floor height, mirrors a proportion of its existing commercial neighbor to the east that is arranged along a 25' platting pattern with a general building height of 16'-8". This proportional framework as a basis for organizing the proposal expresses the intention of UDSG CS2-1-e.

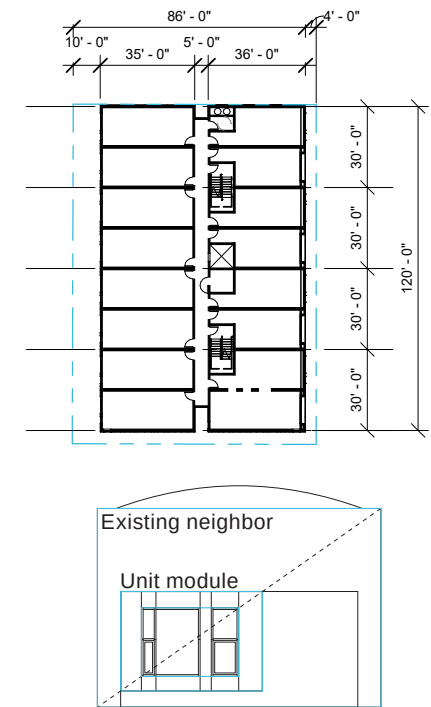

• **Street Level Concept**

A "Block Scale" of apartments are "lifted" above the street level to create a horizontal datum acknowledging and providing deference to the existing smaller scale neighbors. Below, the street level establishes a porous base with pedestrian scale building elements. These elements include a predominant double height "entry void" for people, bikes and access for on site move-in / out needs. By reducing the amount of street level building envelop the concept provides more area for people and bikes and places for people to live. Two angled bays at the street serve the residential needs, however the proposal responds to the board direction to accommodate potential commercial uses at the street with the potential to convert a bay into a retail kiosk or pop-up style retail space. The residential amenity required by zoning is all located on the roof terrace. At the street level common lobby, leasing, mail and parcel program remains. Addition setback from the ROW is proposed. Behind the street level building is an outdoor, covered recreational area for residents.

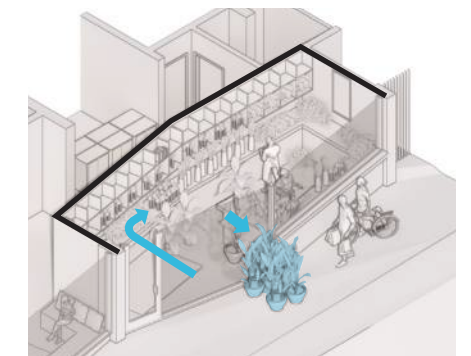
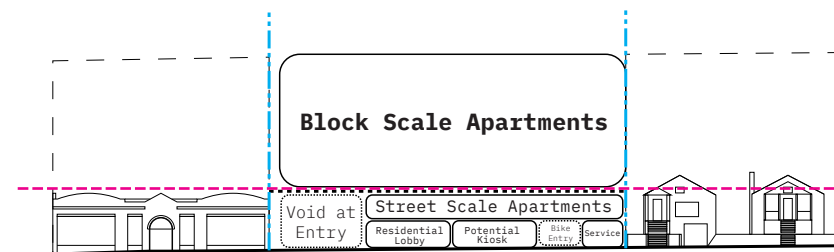

MESSAGE TO THE BOARD

• **Facade Concept - East**

The east, or street facing facade is modulated at the street level as noted above into several smaller scale elements such as angled bays, recessed entries and multiple points of entry and access for residents, bicycles and services. A single story bar of apartments above the street provides overhead weather protection within an increased setback area. The upper portion of the proposal introduces a clearly defined "block scale" facade with recessed balconies 30' apart reflecting a similar urban grain and platting pattern as the proposal's block and the block across Roosevelt Way NE. Additionally the width to height of the recessed balconies are proportional to the fenestration patterns of it's neighbor to the south. **(Please see pp. 51,55)**

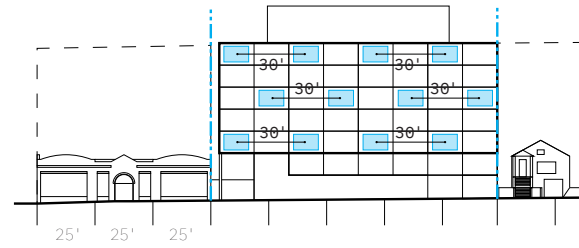

• **Facade Concept - West**

Like the east, the west facade also expresses a 30' wide module by recessing the upper level with alternating terraces. The terraces signal a change from the more intense NC3 zone to an LR2 zone. Due to the existing topography the proposal's site is lower than the adjacent sites to the west. A section diagram indicates a single story recess adds modulation, scale and rhythm similar to its context. **(Please see p. 56)**

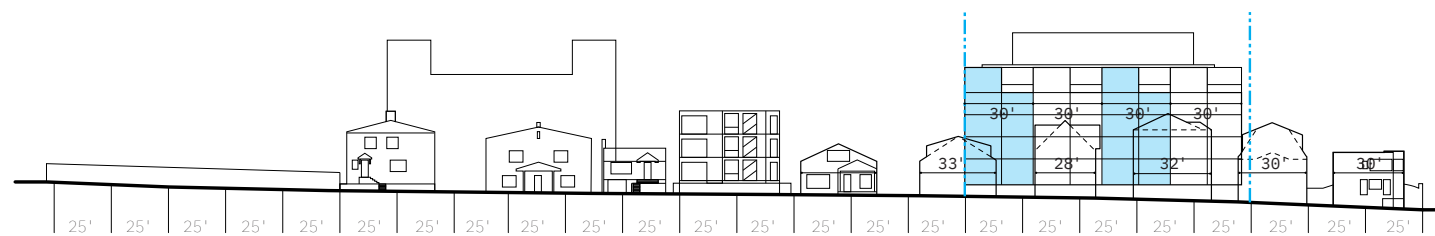

• **Facade Concept - Interior Lot lines**

Revisions to the plan arrangement allows for a break in the north and south interior lot line facades as well as natural daylight into the floor plates. Additionally the proposal shifted the structure north to allow for corner glazing facing south thus providing more interest and modulation. The south facade was noted by the design review board as being the facade to likely be more visible for a longer period of time before redevelopment than the north. **(Please see pp. 66-69).**

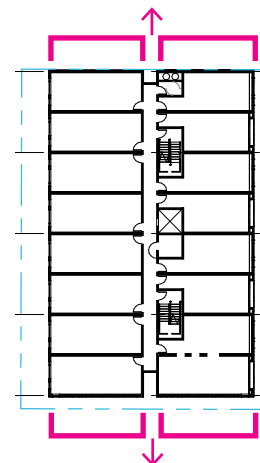

• **Additional Project Development Summary Since EDG**

In addition to the reconsidering aspects of the building to respond the Design Review Board's direction the proposal also:

- Increased the number of units and space for people to live by reconsidering enclosed garage and back of house space as an open-air space for residents at the street level.
- Reconfigured the residential floor levels to maximize units along the facades by relocating vertical circulation and services to the interior of the floor plate. This positions taller rooftop features to the center of the roof. Thus reducing a sense of height, bulk, and scale to the street façade.
- Relocated the building entry to the south, to separate people and bikes from trash and recycling access. Reconsidered the access point as a prominent building entry rather than a garage entry.
- Removed at grade units and terraces along the west facade to allow for more openness, and privacy with adjacent neighbors.
- Replaced 12 parking stalls and drive with an open-air "sports court" area for residents. On site move-in / out and package delivery planned within sports court area.
- Set the street level facade back and additional 7'-8" +/- from the 4'-0" ROW setback than the previous street level concepts.
- Considered ways to introduce the potential for a future retail kiosk space at the street level for the changing needs of the building over time.
- Proposes 100% of overhead weather protection between 8'-0" and 13'-0" above the sidewalk.
- Proposes all required by zoning residential amenity are located on a roof level terrace which is setback from the building edges to respect adjacent neighbors.

Thank you for your time and consideration,

Julia Nagele, Senior Principal
Director of Design - HEWITT Architecture



MESSAGE TO THE BOARD



OneU 1013 NE 45th Street



UDT 1107 NE 45th Street



Capitol Hill TOD



2407 1st Avenue
Rendering by Herzog & de Meuron - Design Consultant
Hewitt Architecture - Executive Architect



Luna 2745 California Ave SW



Luna 2745 California Ave SW



Leeann 701 5th Avenue N

RELEVANT U DISTRICT AND MID-RISE PROJECTS BY
HEWITT DESIGN TEAM

PROJECT VALUES

DESIGN STUDY

1 MAXIMIZE PLACES TO LIVE



+ "Cities are the absence of physical space between people and companies. They are proximity, density, closeness. They enable us to work and play together, and their success depends on the demand for physical connection."
-*Triumph of the City*, Edward Glaeser, Professor of Economics, Harvard University

2 DESIGN CONCEPT



+ Design to strengthen fundamental urban conditions found in the neighborhood.

3 FLEXIBLE USES



+ Consider the complexity of residential program; ie spaces having multiple functions and uses over time.

4 PAST, PRESENT & FUTURE



+ Consider the future growth of the under improved block.

5 FABRIC BUILDING



+ The role of a mid-block, in-fill structure within the block

6 HEALTH AND WELLNESS



+ Provide a variety of outdoor recreation opportunities and promote multi-nodal transportation opportunities

PROJECT GOALS

H

10

COMMUNITY OUTREACH SUMMARY

The project team for 4709 Roosevelt Way NE submitted an outreach plan to the Department of Neighborhoods on March 9th, 2021. All community outreach requirements were fulfilled by June 3rd, 2021. The team deployed three outreach methods: Digital (a project website with interactive function went live on May 18th, 2021 and is publicly available for at least 21 days), Print (10 posters posted within 500ft of the project, a site poster posted on May 19th, 2021), and In-person (a community meeting held on June 3rd, 2021). One of the multi-pronged print methods, local newspaper ad, was not fulfilled, but the high-impact method (10 posters) and the other multi-pronged print method (on-site poster) were fulfilled, which complies with the Director's rule.

SUMMARY OF COMMUNITY FEEDBACK

Throughout all the outreach efforts, no one directly contacted the project team, and five community members attended the in-person community meeting. They provide feedbacks on what they expect in this project as well as ask some questions about the project itself.

Most common questions are:

- **Environmental sustainability**
Does the developer consider any sustainable use in the project?
- **Timeline / Timeframe**
When is the project going to end? How long will it take for the permitting process? When is the project going to start actually? How long will it take for the construction?
- **Networking**
Since Onelin Capital is the developer for the project, and all the audience members are students from nearby areas, how does the construction management student be a pro-developer in the future?
- **Construction**
What kind of building foundation will be used for this project? Soil type if known? Does the wood frame or steel frame have any effect on the acoustic insulation purpose?
- **Experience**
How many project or building have Onelin Capital have been built?

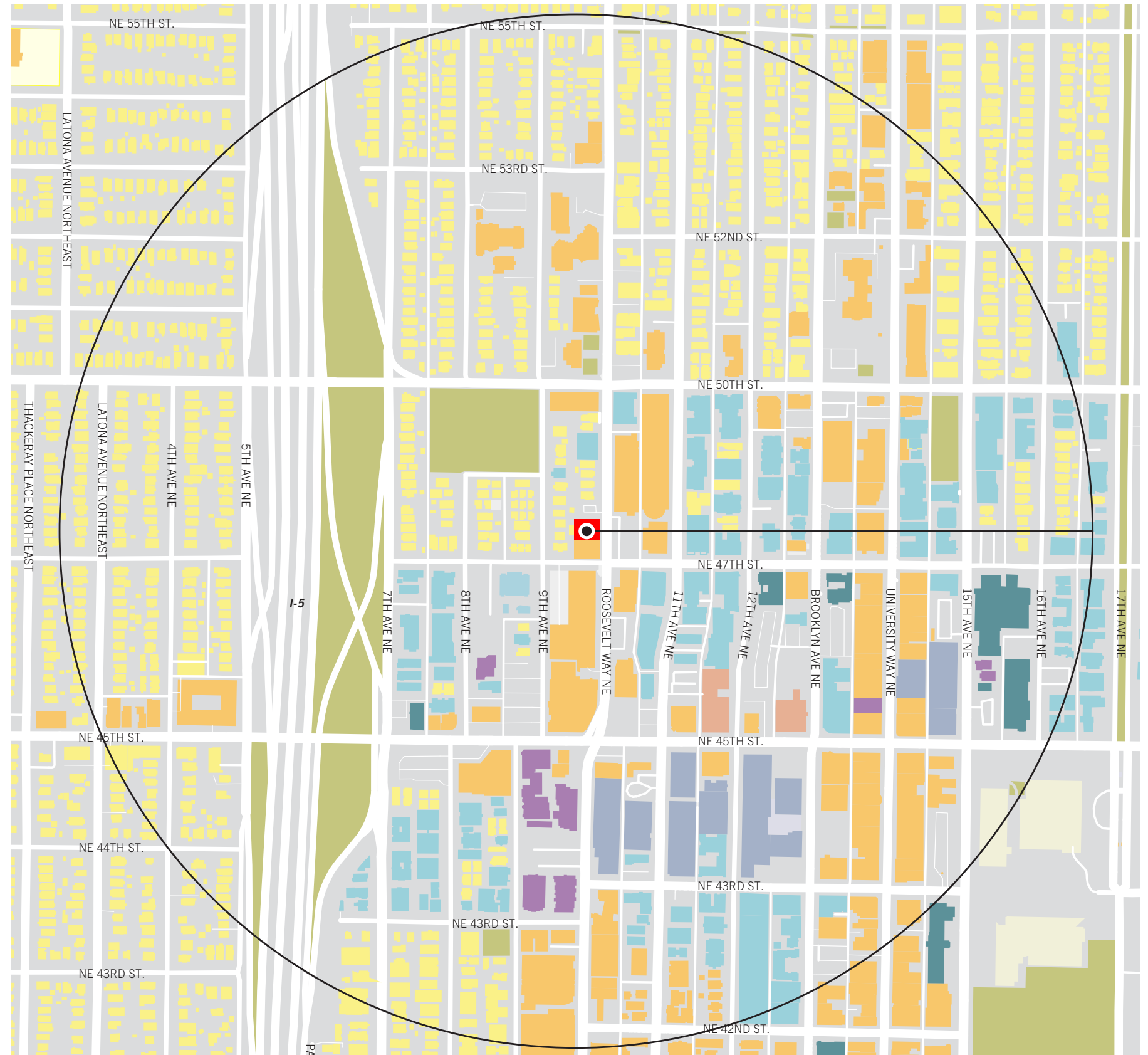

SUMMARY OF COMMUNITY OUTREACH (by others)



AREA MAP



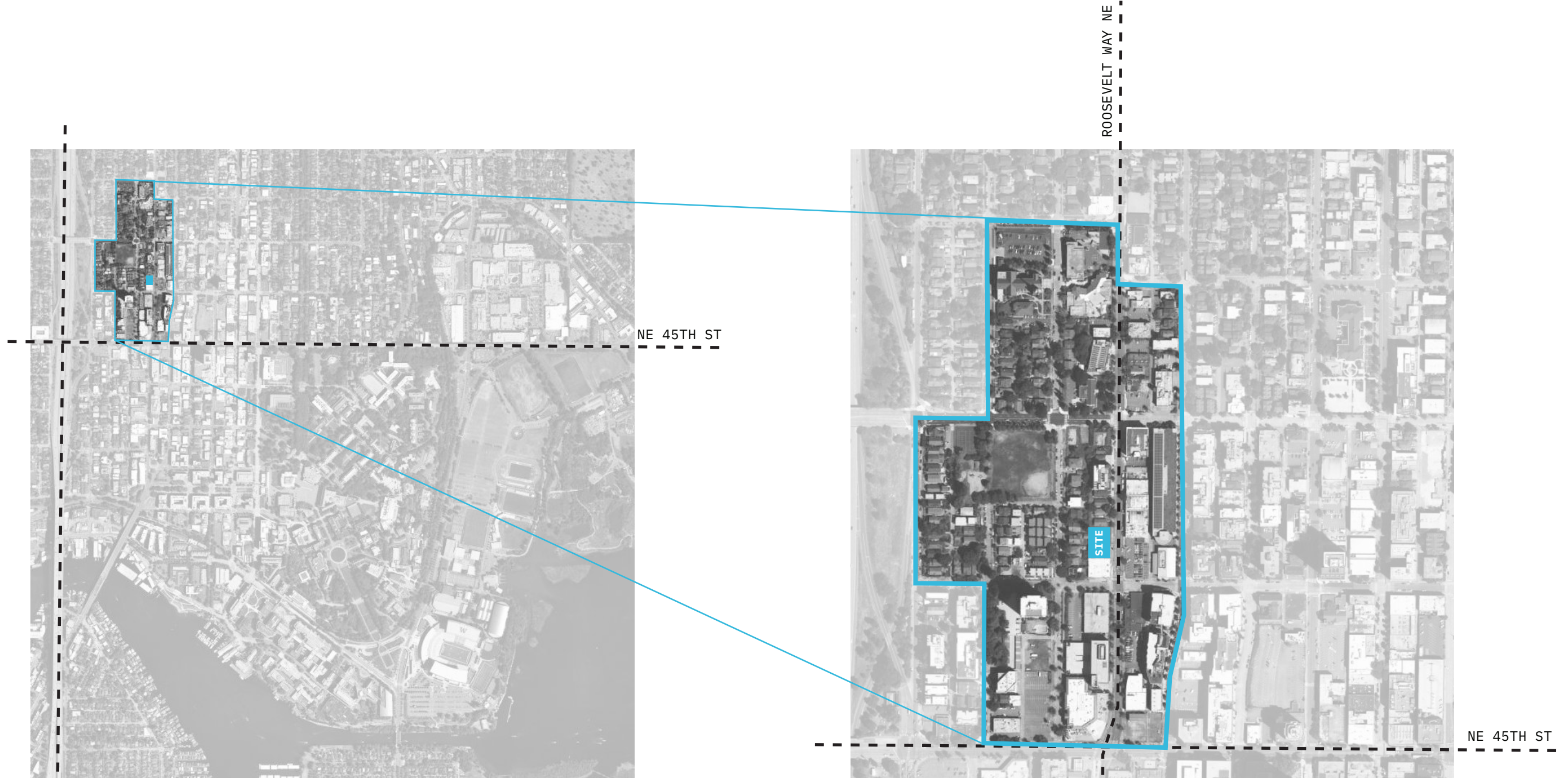

SURROUNDING 9-BLOCK AREA OF
UNIVERSITY DISTRICT



H



SURROUNDING 9-BLOCK AREA OF UNIVERSITY DISTRICT

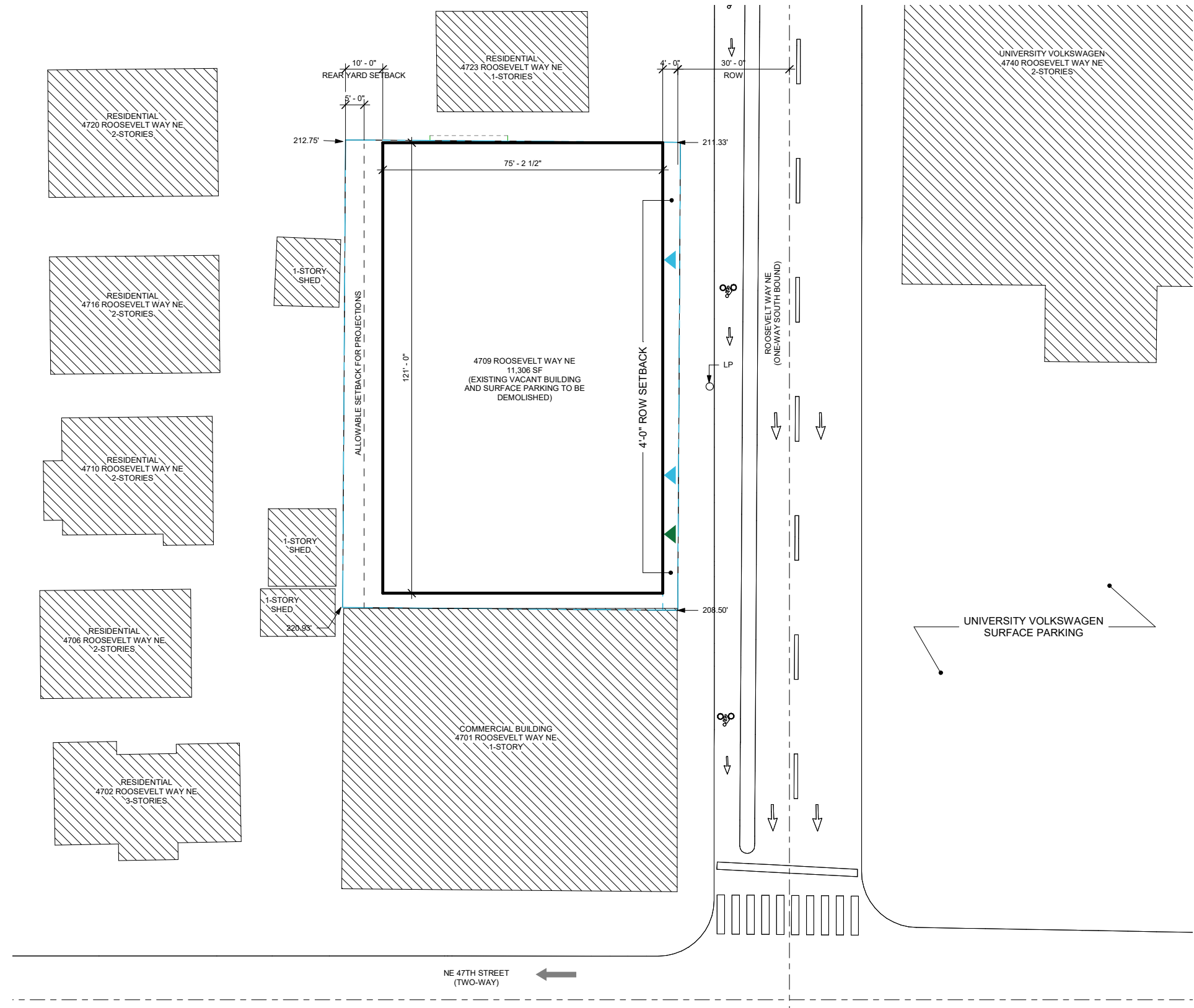

OVERALL SITE

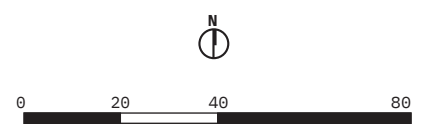

- ▶ MOVE-IN / OUT ACCESS
- ▶ PEDESTRIAN ACCESS

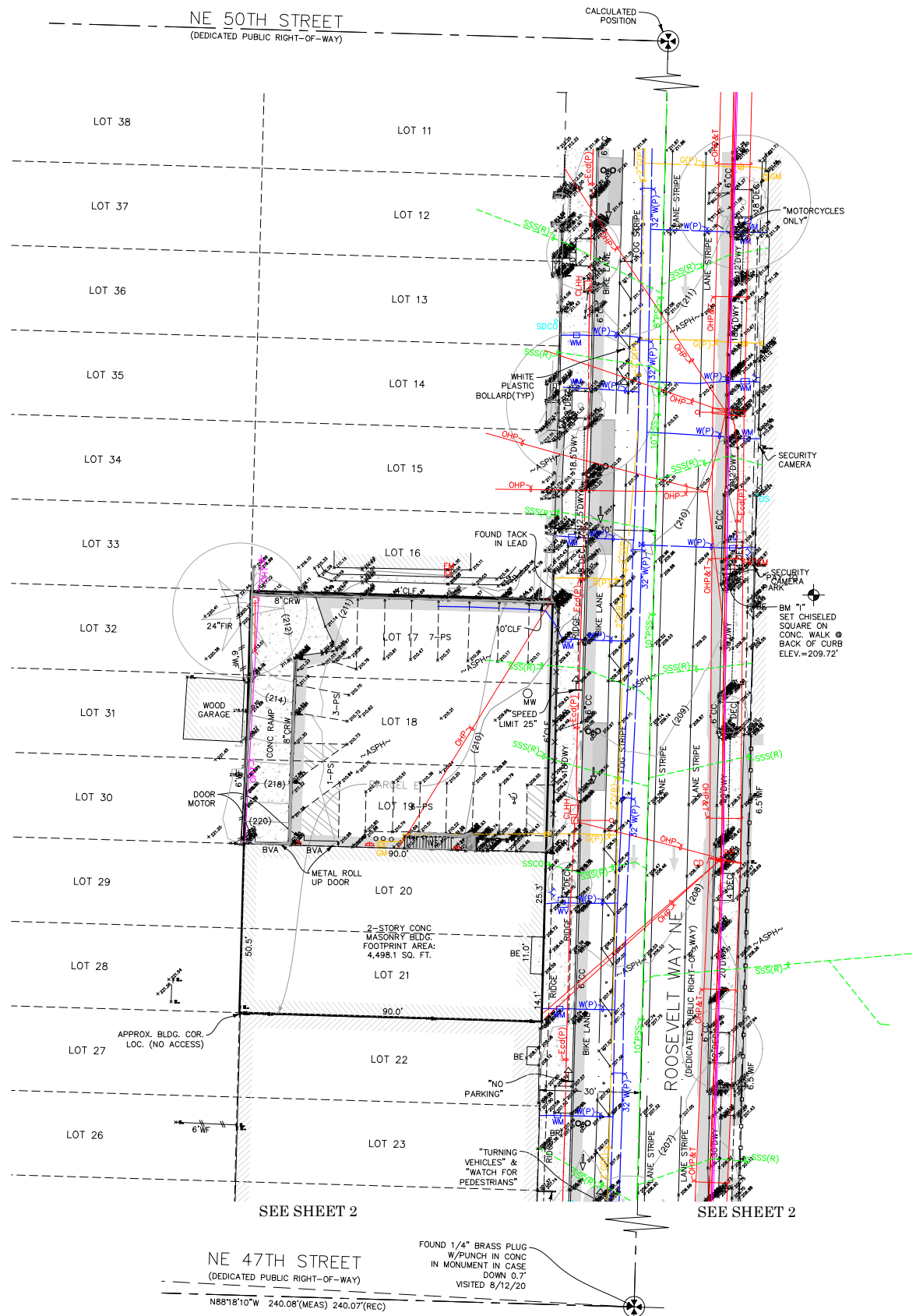

SITE SURVEY

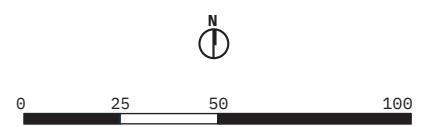

02 | SITE CONTEXT



SURROUNDING USES



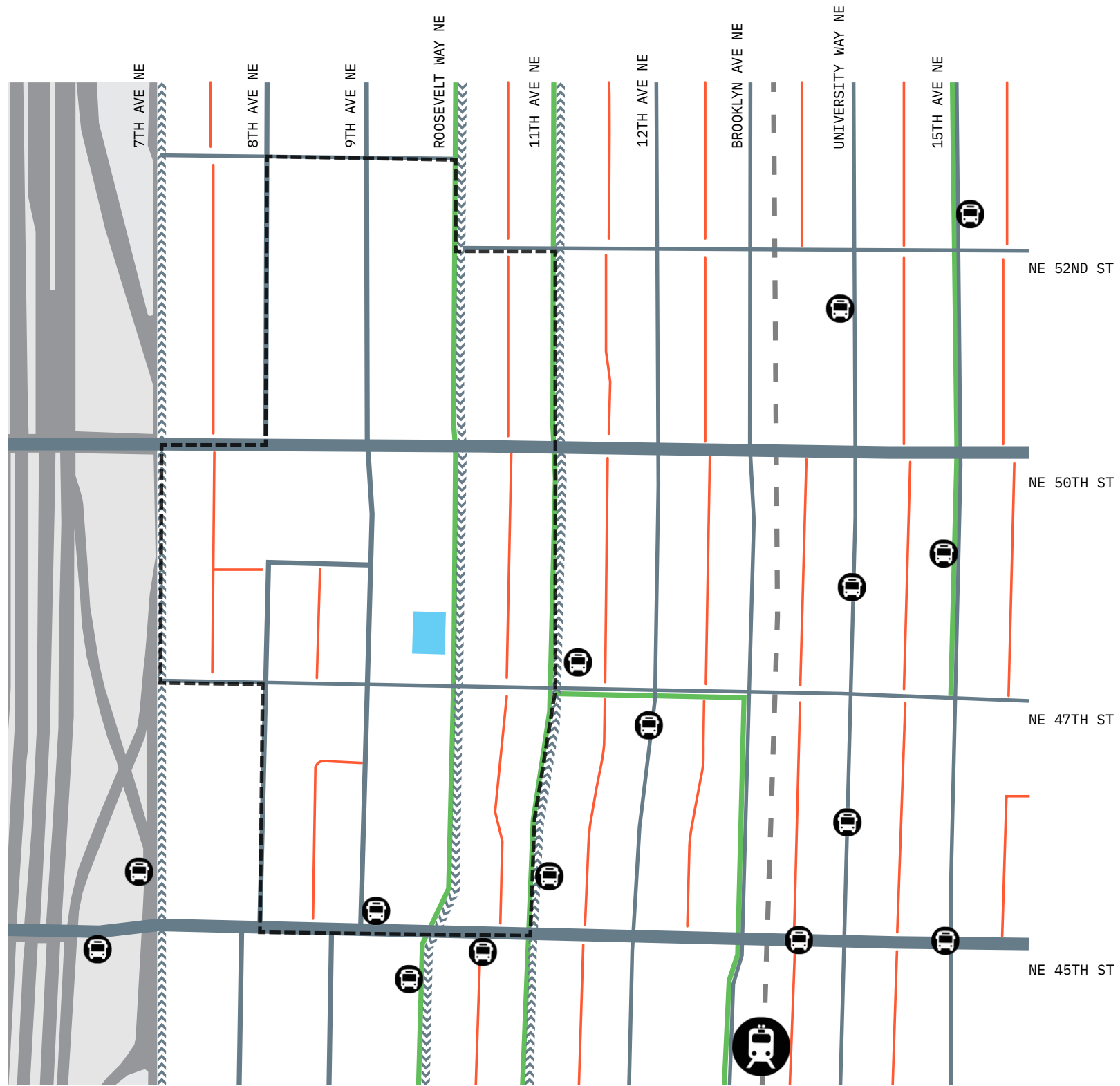

- SITE
- 9 BLOCK AREA
- ONE WAY STREET
- TWO WAY STREET
- TWO WAY STREET - QUAD LANE
- DEDICATED BIKE LANE
- ALLEY
- Ⓚ BUS STOP
- Ⓜ LIGHT RAIL STOP

TRAFFIC ANALYSIS

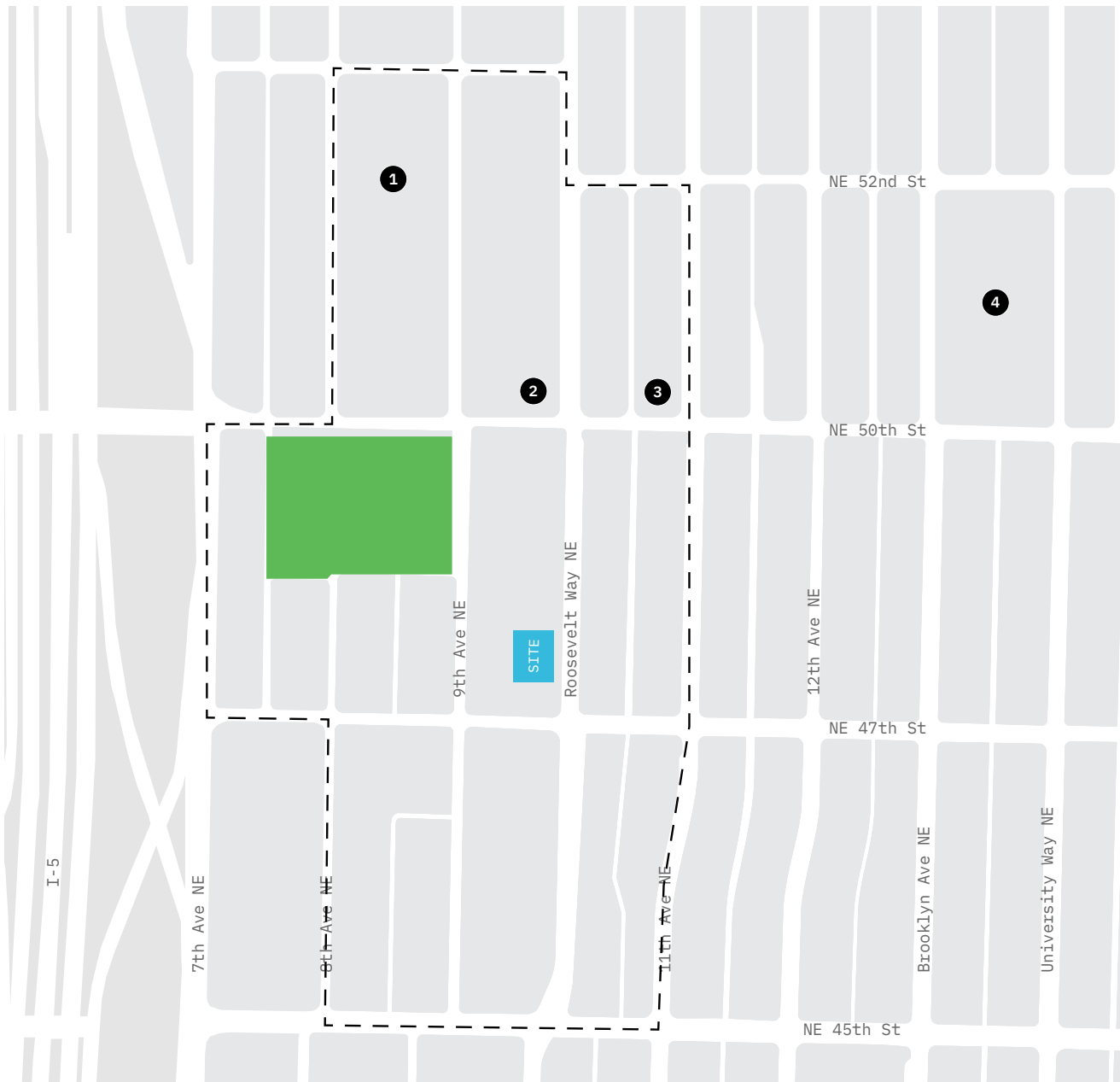

1
 Blessed Sacrament
 Catholic Church
 5050 8th Ave NE



4
 University Heights
 Elementary School
 5031 University Way
 NE



2
 University Branch
 Seattle Public Library
 5009 Roosevelt Way
 NE



3
 Seattle Fire Station 17
 1050 NE 50th St

LANDMARKS



ROOSEVELT WAY NE,
FACING WEST



47TH

SITE

50TH →

ROOSEVELT WAY NE,
FACING EAST

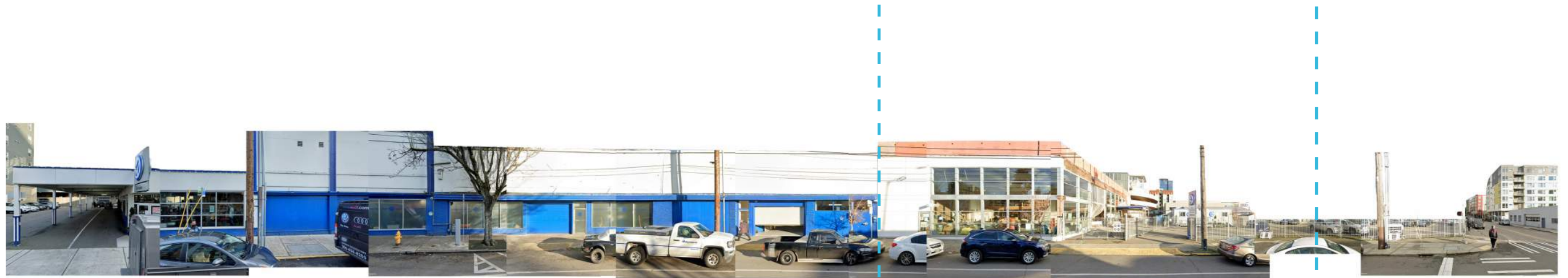

← 50TH

OPPOSITE

47TH

STREET ELEVATIONS

9:00 AM

12:00 PM

3:00 PM

JUNE 20 - SUMMER SOLSTICE

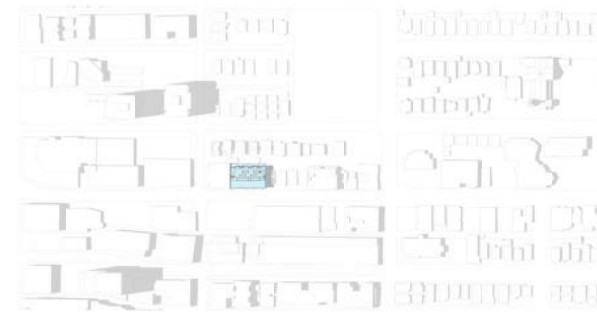

SEPTEMBER 22 - EQUINOX



DECEMBER 21 - WINTER SOLSTICE

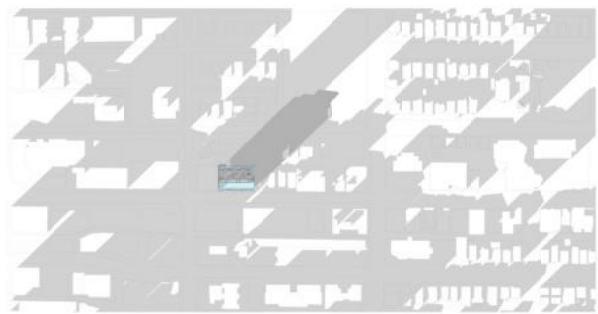

SOLAR ANALYSIS



9:00 AM

12:00 PM

3:00 PM

EXISTING

SEPTEMBER 22 -
EQUINOX



PROPOSED

SEPTEMBER 22 -
EQUINOX

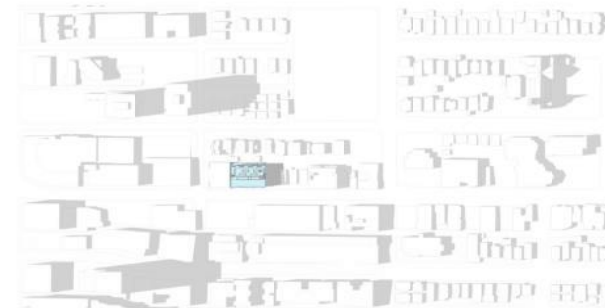

SOLAR ANALYSIS



Vashon Glacial sheet creates Green Lake, maintaining natural firs and cedars of the University District.



50,000 BC

8,000 BC



Duwamish tribes live in longhouses and fish salmon along the future Lake WA Ship Canal.

Land is surveyed and platted on US grid, occupied twelve years later by the first settlers.



1855

1890



The then-called "Brooklyn" area, ship canal, and lakeside industry are annexed into Seattle.

Alaska-Yukon-Pacific Exposition, a world's fair held on the grounds of the University of Washington

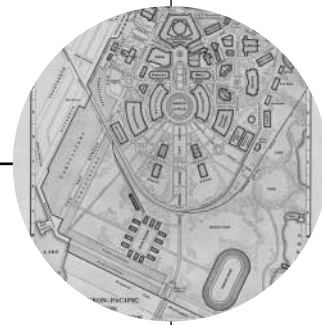

1909

1934



Students participate in the final "Campus Day" by clearing stumps and brush to initiate yearly University studies.

Shiga's Imports (4306 University Way NE) established



1956



Andy Shiga was a businessman, social activist, and is credited for proposing the U District Street Fair and contributing to the diverse identity of the "Ave".

1990



Modern housing and businesses support the 40,000 student population at UW and the expanding "innovation hub" to the west.

SITE HISTORY



TOPOGRAPHY



25

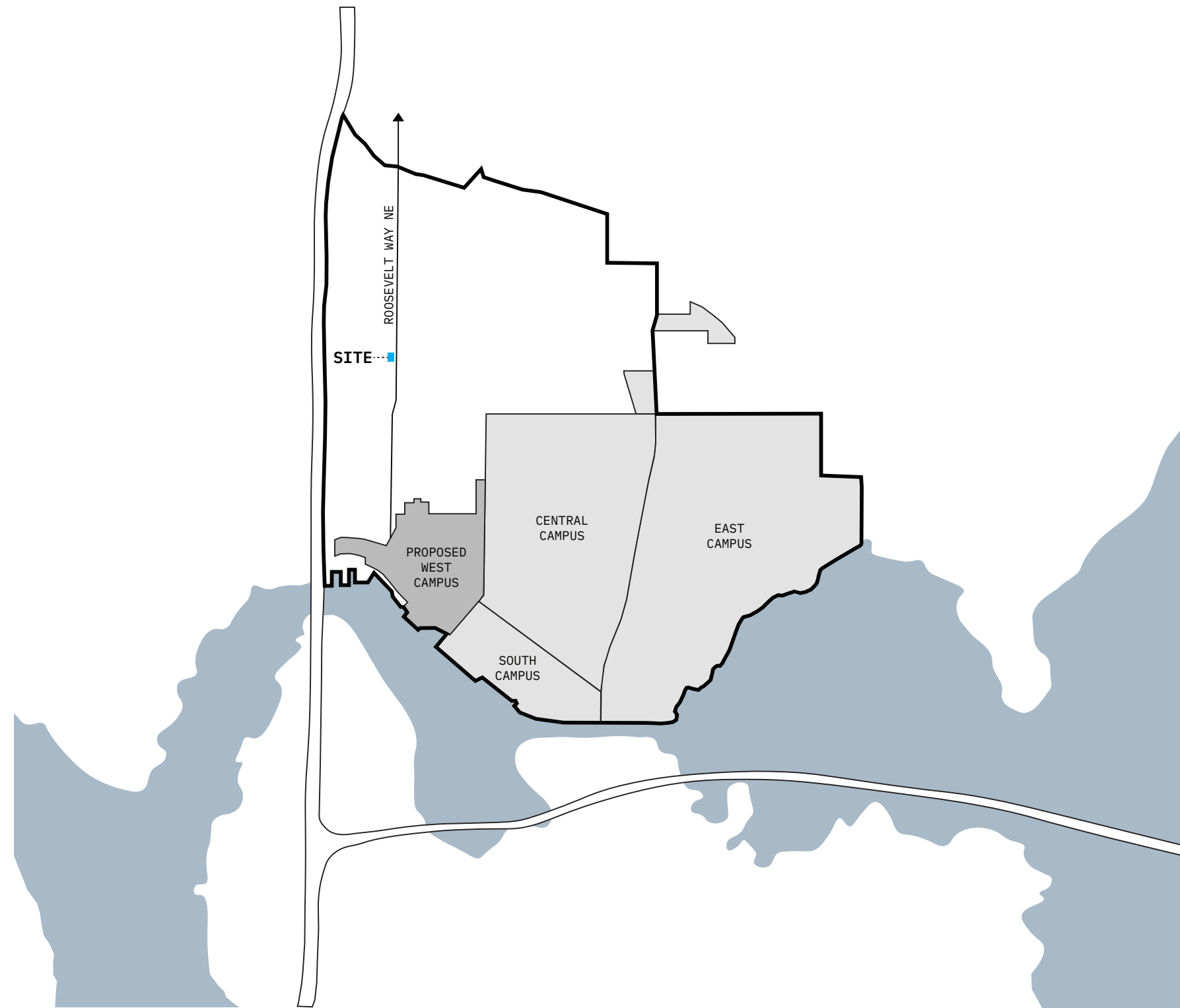

The University of Washington proposed high rise "innovation district" calls for up to 6 million square feet in new construction to accommodate another 7,000-plus students and employees. The project will bring affordable housing and high-rises as tall as 17 stories in West Campus and in South campus, around the medical center.



U DISTRICT URBAN DESIGN FRAMEWORK

Reference: " U District Urban Design Framework" June 2013. Figure "Gateways, Hearts and Edges," Page 17

03 | EXISTING SITE



A. 47TH ST looking North



B. Roosevelt Way NE looking South West



C. Roosevelt Way NE looking North West



D. Roosevelt Way NE looking West

It is assumed all existing street curb cuts and aprons will be relocated. Vehicle access for building service will occur off of Roosevelt Ave. Our site observation does not indicate any overhead power line conflicts or setback requirements as well as any presence of exceptional trees on the site.

- 1. EXISTING DEDICATED BIKE LANE
- 2. EXISTING BUILDING (TO BE REMOVED)
- 3. EXISTING CURB CUT (TO BE Relocated)

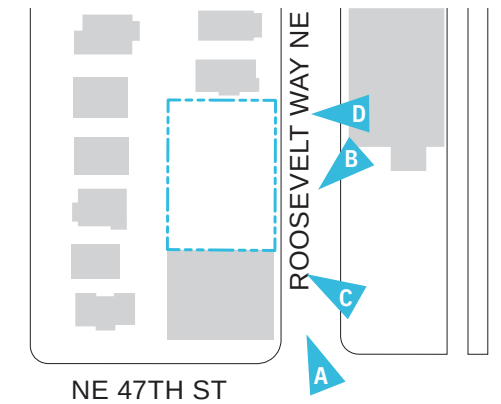

EXISTING SITE CONDITIONS

04 | ZONING

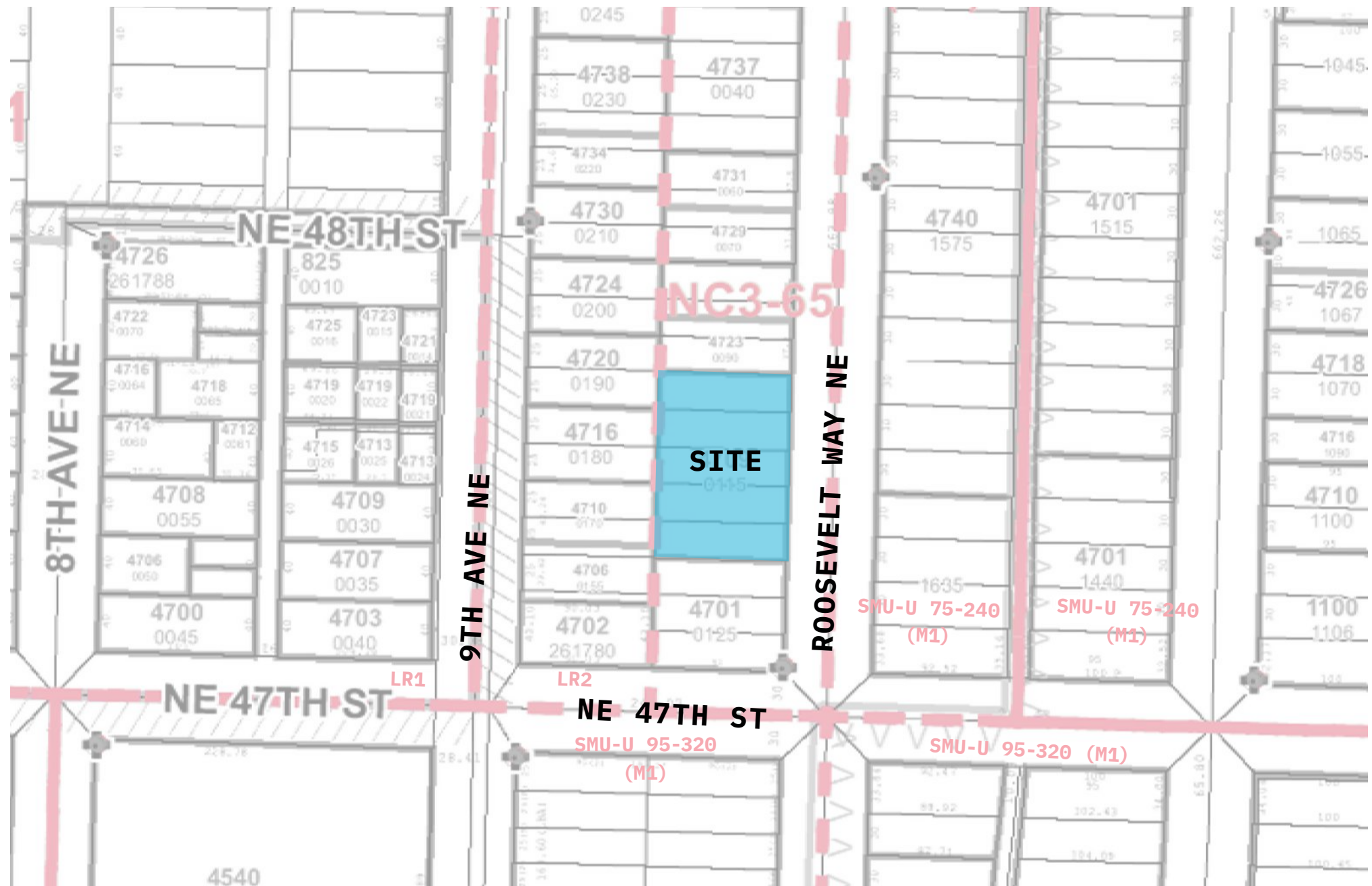

ZONING MAP



H

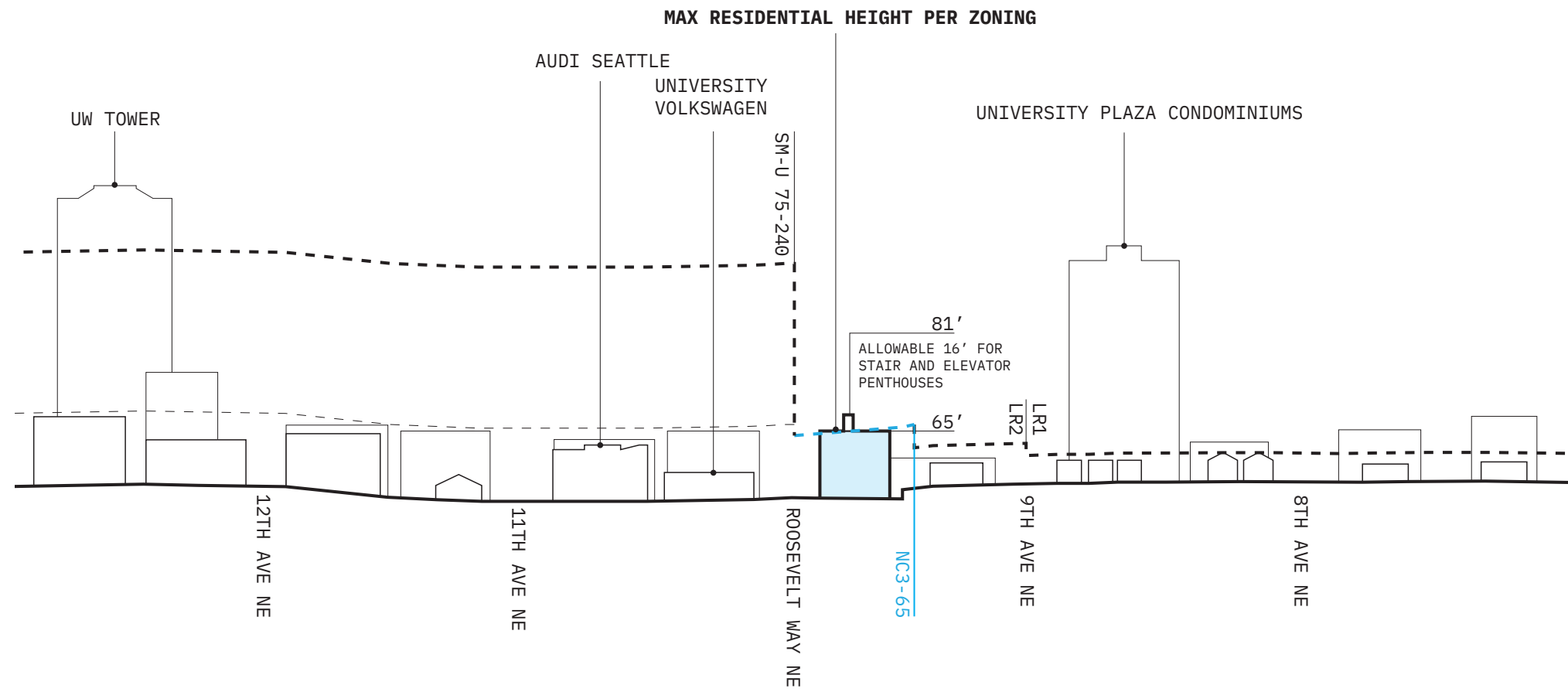
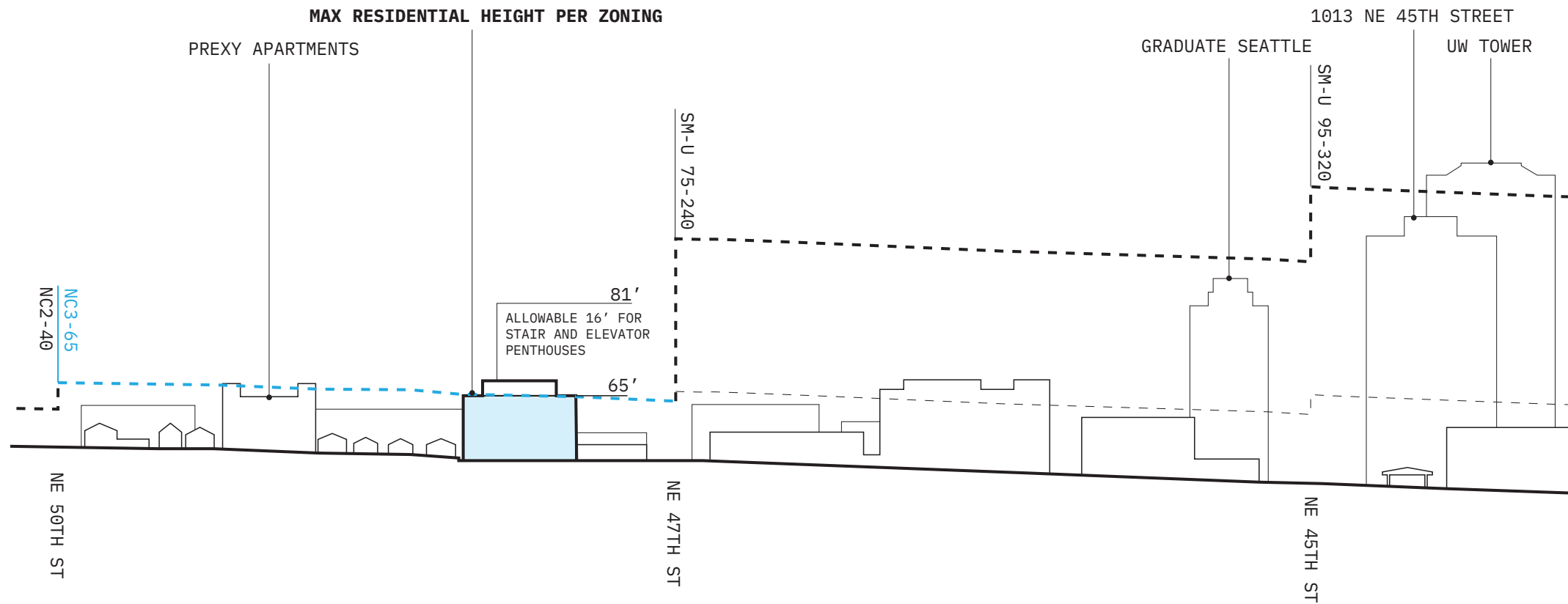

STREET ELEVATIONS

ZONING

23.47A.014
Setback requirements

B. Setback requirements for lots abutting or across the alley from residential zones

2. An upper-level setback is required along any rear or side lot line that abuts a lot in an LR, MR, or HR zone or that abuts a lot that is zoned both commercial and LR, MR, or HR if the commercial zoned portion of the abutting lot is less than 50 percent of the width or depth of the lot, as follows:

a. Ten feet for portions of structures above 13 feet in height to a maximum of 65 feet; and

b. For each portion of a structure above 65 feet in height, additional setback at the rate of 1 foot of setback for every 10 feet by which the height of such portion exceeds 65 feet, up to a maximum setback of 20 feet

23.47A.014
Setback requirements

G. Structures and projections in required setbacks

1. Decks and balconies

a. Decks with open railings may extend into the required setback, but are not permitted within 5 feet of a lot in a residential zone, except as provided in subsection 23.47A.014.G.1.b.

5. Fences, bulkheads, freestanding walls, and other similar structures

a. Fences, freestanding walls, and other similar structures 6 feet or less in height above existing or finished grade, whichever is lower, are permitted in required setbacks. The 6-foot height may be averaged along sloping grade for each 6-foot-long segment of the fence, but in no case may any portion of the fence exceed 8 feet.

b. Bulkheads and retaining walls used to raise grade may be placed in any required setback when limited to 6 feet in height, measured above existing grade. A guardrail no higher than 42 inches may be placed on top of a bulkhead or retaining wall existing as of September 30, 1994. If a fence is placed on top of a new bulkhead or retaining wall, the maximum combined height is limited to 9.5 feet.

c. Bulkheads and retaining walls used to protect a cut into existing grade may not exceed the minimum height necessary to support the cut or 6 feet, whichever is greater. When the bulkhead is measured from the low side and it exceeds 6 feet, an open guardrail of no more than 42 inches meeting Building Code requirements may be placed on top of the bulkhead or retaining wall. A fence must be set back a minimum of 3 feet from such a bulkhead or retaining wall.

6. Setback requirements do not limit underground structures.

ZONING

23.47A.024
Amenity area

A. Amenity areas are required in an amount equal to 5 percent of the total gross floor area in residential use, except as otherwise specifically provided in this Chapter 23.47A. Gross floor area, for the purposes of this subsection 23.47A.024.A, excludes areas used for mechanical equipment and accessory parking. For the purposes of this subsection 23.47A.024.A, bioretention facilities qualify as amenity areas.

B. Required amenity areas shall meet the following standards, as applicable:

1. All residents shall have access to at least one common or private amenity area.

2. Amenity areas shall not be enclosed.

3. Parking areas, vehicular access easements, and driveways do not qualify as amenity areas, except that a woonerf may provide a maximum of 50 percent of the amenity area if the design of the woonerf is approved through a design review process pursuant to Chapter 23.41.

4. Common amenity areas shall have a minimum horizontal dimension of 10 feet, and no common amenity area shall be less than 250 square feet in size.

5. Private balconies and decks shall have a minimum area of 60 square feet, and no horizontal dimension shall be less than 6 feet.

6. Rooftop areas excluded because they are near minor communication utilities and accessory communication devices, pursuant to subsection 23.57.012.C.1.d, do not qualify as amenity areas.

23.47A.013
Floor area ratio

B. The following gross floor area is not counted toward FAR:

1. All stories, or portions of stories, that are underground;

2. All portions of a story that extend no more than 4 feet above existing or finished grade, whichever is lower, excluding access;

RELEVANT ZONING SECTIONS

ZONING

23.86.007

Floor area and floor area ratio (FAR) measurement

A. Gross floor area. Except where otherwise expressly provided in this Title 23, gross floor area shall be as defined in Chapter 23.84A and as measured in this Section 23.86.007. The following are included in the measurement of gross floor area in all zones:

- 1. Floor area contained in stories above and below grade;
- 2. The area of stair penthouses, elevator penthouses, and other enclosed rooftop features;

3. The area of motor vehicle and bicycle parking that is enclosed; and

4. The area of motor vehicle parking that is covered by a structure or portion of a structure.

B. Net unit area. Where development standards refer to net unit area, net unit area shall include all floor area bounded by the inside surface of the perimeter walls of the unit, as measured at the floor line. Net unit area excludes spaces shared by multiple units and accessible to all building occupants such as common hallways or lobbies. Net unit area includes any walls internal to the unit.

23.86.007 (cont)

Floor area and floor area ratio (FAR) measurement

C. Underground floor area. Except as otherwise expressly provided in this Title 23, if gross floor area in stories, or portions of stories, that are underground is exempted from a calculation, the amount of underground gross floor area exempted is measured as follows:

- 1. A story or portion of a story is considered underground if the ceiling above, or the roof surface if there is no next floor above, is at or below the abutting existing or finished grade, whichever is lower (See Exhibit A for 23.86.007).
- 2. To determine the amount of gross floor area that is underground:
 - a. Determine the elevation of the ceiling of the underground story, or the roof surface if there is no next floor above the underground story;
 - b. Determine the points along the exterior wall of the story where the ceiling elevation or roof surface elevation above intersects the abutting corresponding existing or finished grade elevation, whichever is lower;
 - c. Draw a straight line across the story connecting the two points on the exterior walls;
 - d. The gross floor area in stories, or portions of stories, that are underground is the area that is at or below the straight line drawn in subsection 23.86.007.C.2.c.

ZONING

23.47A.008

Street Level development standards

C. In addition to the provisions of subsections 23.47A.008.A and 23.47A.008.B, the following standards also **apply in pedestrian designated zones:**

- 1. A minimum of 80 percent of the width of a structure's street-level street-facing facade that faces a principal pedestrian street shall be occupied by uses listed in subsection 23.47A.005.D.1. The remaining 20 percent of the street frontage may contain other permitted uses and/or pedestrian entrances (see Exhibit A for 23.47A.008).
- 4. Overhead weather protection
Continuous overhead weather protection (i.e., canopies, awnings, marquees, and arcades) is required along at least 60 percent of the street frontage of a structure on a principal pedestrian street, except for structures within the Pike/Pine Conservation Overlay District on lots that contain a character structure as provided in Chapter 23.73.

Please note while the project fronts a principal pedestrian street, it is not in a pedestrian zone and therefore is not required by zoning to meet section SMC 23.47A.008.C. However, the project is proposing measures in the spirit of this section such as overhead weather protection

RELEVANT ZONING SECTIONS

05 | RELEVANT DESIGN GUIDELINES

CITY WIDE GUIDELINE | CS2 - URBAN PATTERN AND FORM

Strengthen the most desirable forms, characteristics, and patterns of the streets, block faces, and open spaces in the surrounding area.

D. HEIGHT, BULK, AND SCALE

3. Zone Transitions: For projects located at the edge of different zones, provide an appropriate transition or complement to the adjacent zone(s). Projects should create a step in perceived height, bulk and scale between the anticipated development potential of the adjacent zone and the proposed development.

Factors to consider:

- a. Distance to the edge of a less (or more) intensive zone;
- b. Differences in development standards between abutting zones;
- c. The type of separation from adjacent properties (e.g. separation by property line only, by an alley or street or open space, or by physical features such as grade change);
- d. Adjacencies to different neighborhoods or districts; adjacencies to parks, open spaces, significant buildings or view corridors; and
- e. Shading to or from neighboring properties

+ Response: The west property line of the site abuts a less intense LR2 zone. While the existing structures to the west resemble single family structures, the west part of the block is a multi-family zone and the existing structures contain multiple residential units. The overall existing development of the LR2 zone of the block is underdeveloped. *(Please see p. 48).* Additionally the western half of the block is higher in elevation than the east. This change in grade assists with transitioning between the different zones. *(Please see pp. 72 showing the differences in elevation.)*

CITY WIDE GUIDELINE | CS2 - URBAN PATTERN AND FORM

D. HEIGHT, BULK, AND SCALE

4. Massing Choices: Strive for a successful transition between zones where a project abuts a less intense zone. In some areas, the best approach may be to lower the building height, break up the mass of the building, and/or match the scale of adjacent properties in building detailing. It may be appropriate in other areas to differ from the scale of adjacent buildings but preserve natural systems or existing features, enable better solar exposure or site orientation, and/or make for interesting urban form.

+ Response: Modulation and upper level setbacks on the west facade are proposed. *(Please see pp. 70-75 for a detailed response).*

CITY WIDE GUIDELINE | CS2 - URBAN PATTERN AND FORM

D. HEIGHT, BULK, AND SCALE

5. Respect for Adjacent Sites: Respect adjacent properties with design and site planning to minimize disrupting the privacy and outdoor activities of residents in adjacent buildings.

+ Response: Design strategies proposed for the west facade are to setback sections of the upper level facade with recessed terraces and to remove the grade level units and terraces proposed at EDG1 with a porous edge offering relief from the neighbors. Recessed Juliette balconies are proposed on the east facade while upper level setbacks are proposed on the west. Respect of adjacent sites and privacy is considered by recessing the outdoor spaces for residents. The open air "sports court" at the street level, at the west edge of the site is technically below grade and mainly out of view from the west, adjacent properties. The roof terrace amenity area for residents is also set back to respect adjacent sites. *(Please see pp. 75; 78,80 for more information).*

Above are city-wide design guidelines that informed the EDG2 concepts and are in addition to the guidelines referenced in the EDG 1 Meeting Report.

RELEVANT DESIGN GUIDELINES

U DISTRICT SUPPLEMENTAL GUIDELINE | DC2 - ARCHITECTURAL CONCEPT

Develop an architectural concept that will result in a unified and functional design that fits well on the site and within its surroundings.

2. Architectural Concept & Facade Composition

a. Embrace contemporary design through distinctive, elegant forms that demonstrate a context-sensitive approach to massing and facade design.

Response: The facade design takes its design cues from the proportions and organization of the existing context. This includes the neighborhood platting patterns and the adjacent commercial structure to the south and a consideration of the site's mid-block condition. A clear, block massing above the street anchors the variety of building elements along the street front. The street front building elements establish smaller scales and a variety of experiences along the public way such as open areas providing views into and through the site. [\(Please see pp. 58, 94-100 for additional information\).](#)

Above is a neighborhood-wide design guideline that informed the EDG2 concept and are in addition to the guidelines referenced in the EDG 1 Meeting Report.

RELEVANT DESIGN GUIDELINES

06 | EDG 1 ALTERNATIVES



ALTERNATIVE 1

Opportunities

- Strong urban edge on Roosevelt Way NE.
- Top level highlighted in contrasting material reduces the scale and bulk of the mass.
- West facade terrace produces a buffer layer.
- No departure Requests

Constraints

- Due to property line & dedication on Roosevelt Way NE, overhang doesn't read well.
- Building mass is potentially too 'simple'.



ALTERNATIVE 2

Opportunities

- Strong urban edge on Roosevelt Way NE.
- Building is split into two masses which helps reduce the scale of the development.
- West facade terrace produces a buffer layer
- No departure Requests

Constraints

- Building mass is potentially too 'simple'.
- No gesture to reduce bulk and scale of building.
- Commercial and residential entry combined under one canopy



ALTERNATIVE 3

Opportunities

- Strong urban edge on Roosevelt Way NE.
- Corner recesses highlighted in contrasting material, reduces the scale and bulk of the mass.
- West facade terrace produces a buffer layer.
- No departure Requests

Constraints

- Building is potentially too tall.

* Alternatives, Opportunities and Constraint Summaries by others

EDG 1 ALTERNATIVE SUMMARY

07 | BOARD EDG 1 DIRECTION

1. SITE CONTEXT AND ANALYSIS

a. The Board discussed the lack of information contained in the packet regarding the building design's response to context. The Board noted that the packet did not go far enough with the context analysis, which made it difficult to understand the dimensional relationship between the proposed building and the existing building. The Board requested the applicant consider the existing building's relationship to the proposed building and how that could impact the north and south facades. The Board noted that the property immediately north of the project site is likely to be redeveloped due to the existing underdeveloped nature of the site currently. However, the Board suggested the south façade of the building could be visibly prominent for years due to the existing building immediately south of the project site. The Board supported the use of balconies shown in Option 3 stating that this component was responsive to the existing context in the neighborhood. **(CS2.B.1, CS2.C.2, University Supplemental Guidance – CS2.1.e, CS1.1.c, DC2.2.a)**

+ Response: An updated series of site context analysis exhibits have been provided. **(Please see pp. 46-65)** These exhibits characterize the existing block as under-improved relative to the intentions of the zoning code **(p. 48)**, the urban grain and platting patterns establishing a framework for the proposal's plan arrangement, **(p. 86)** facade concepts **(p. 59,68)** and site organization. **(p. 78)** The proposal analyzed the adjacent, existing structure to the south to provide design cues for the proposal's facade concepts. **(p. 51)** The proposal maintains balconies on the east facade and recessed terraces on the west facade. **(p. 97,99)**

2. MASSING

a. The Board stated Option 1 does not adequately respond to the context of the neighborhood, noting the lack of building articulation and the absence of 20' to 40' building modulation supported in the University Supplemental Design Guidelines. While the Board noted the vertical elevator in Option 2 provided a meaningful massing move, Option 2 lacked the balconies along Roosevelt to assist in breaking down the building mass. The Board stated that it was difficult to support a building massing design that lacked balconies on Roosevelt Ave. **(University Supplemental Guidance – CS2.1.e, DC2.1.a)**

+ Response: Additional study of the site's context has been completed and informed the revised proposal to meet the above Design Review Board's guidance. The site context informed revisions to the placement of the double-loaded corridor residential block, the plan arrangement based on a 30' wide column grid and module; massing and modulation and facade concept. Recessed balconies and terraces are proposed on the east and west facades. The vertical services and circulation functions were relocated to the center of the floor plate to allow for more apartment area to front the street and thereby placing the elevator and stair penthouse in the center of the roof to reduce the perceived height, bulk and scale. **(Please see pp. 53-58, 86)**

2. MASSING (CONT.)

b. During the Board's review and discussion on Option 3, Board members noted the lack of the building massing breaks in the 20' to 40' range. The Board stated that nothing was happening massing wise at the base and while Option 3 included three vertically oriented moves, it was difficult to relate the moves to the interior functions of the building. The Board was concerned with the lack of modulation on the building's south façade, noting their previous comment regarding the likelihood of this façade being visually prominent for years to come. The Board suggested more articulation along the south façade would be appropriate. **(University Supplemental Guidance – CS2.1.e, DC2.B.2)**

+ Response: Additional study of the site's context has been completed and informed the revised proposal to meet the above Design Review Board's guidance. The upper portions of the proposal is informed by the platting patterns and site characteristics of the neighborhood. The base of the building is proposed to be porous, smaller in scale and setback further from the street. The north and south facades have been modulated along the central corridor with opportunities for glazing. **(Please see pp. 66-69)**

2. MASSING (CONT.)

c. The Board stated that they struggled with all three options and expressed to the applicant that there was not enough exploration done at this stage to move forward with a recommendation from the Board. Out of the three options, the Board identified some support for Option 2 due its overall form, vertical break, balconies on the west façade, and location of the interior uses. The Board requested the applicant further study massing options for the building. This includes studying whether flipping the location of the stairway and elevator will lead to less of a blank wall effect along Roosevelt Avenue. The Board also requested the applicant study how to integrate massing breaks at the 20' to 40' intervals recommended by the University Supplemental Design Guidelines and demonstrate how the interior uses of the building inform the massing design. The Board also requested two dimensional elevations of the updated massing design and east/west and north/south sections of the proposed building in relation to existing buildings. **(DC2.A.1, DC2.B.2, DC2.E, University Supplemental Guidance – CS2.1.e)**

+ Response: The internal plan arrangement has been revised to place the vertical circulation and services to the center of the floor plates to allow for more living area on the street facade. The facade concept is informed by the historic platting patterns and site characteristics of the nearby context. **(Please see pp. 86 for additional information)**

3. ZONE TRANSITION

a. The Board supported the 15' setback along the west property line shown in Options 1 and 2 with the building pushed closer to Roosevelt Ave. The Board supported the introduction of balconies on the west side of the building (shown in all three options) , noting that balconies provided an appropriate relationship with the adjacent single -family dwellings. However, the Board thought the introduction of balconies was not enough, noting the lack of modulation along the west façade. The Board requested the applicant further study ways to soften the western edge of the building and alleviate the 5-story façade. The Board suggested the applicant explore deepening the balconies, creating more of a statement along this façade. **(DC2.C, University Supplemental Guidance CS2.2.b, DC2.2.i)**

+ Response: The design team studied the present and future conditions between the NC3 and LR2 multi-family zone, the under improved state of the current block and the block's urban grain of platting patterns to inform the west facade. In addition to the supplemental design guideline CS2.2.b, the design team reviewed and considered the citywide corresponding guidelines CS2-D, 3-5. The intent of the citywide guideline deals with similar aspects of the supplemental guideline however there was additional language in the guideline regarding respect for adjacent neighbors and privacy with neighbors. This informed the design by proposing recessed notched terraces along the upper story of the proposal. **(Please see pp. 70-75 for additional information)**

4. GROUND PLANE / SITE PLANNING

a. The Board requested the applicant provide a calculation of the required amenity area for the Board members to better understand what the required minimum amenity area for the project is. In addition to this information, the Board requested the applicant provide opportunities to introduce a commercial space at the street level. The Board was concerned the large amenity space at the street level would not activate the street and instead create a dead zone along the building's street frontage. The Board requested the amenity space provide the flexibility to permit a future commercial space(s) to provide for street activation. The Board requested the applicant study the adaptability of the amenity space to convert to commercial spaces in the future. **(DC1.A.3, University Supplemental Guidance PL3.3.f, PL3.3.d, PL3.3.e)**

+ Response: The amenity area required by zoning is proposed to be outdoors per SMC. 23.47A.024.B.2 "Amenity areas shall not be enclosed." The unenclosed amenity area is located on the rooftop terrace. Calculations of required amenity area provided. By removing the amenity area from the street level, the ability to consider future retail uses is proposed. **(Please see pp. 80-81, 88-93 for additional information)**

4. GROUND PLANE / SITE PLANNING (CONT.)

b. The Board expressed concern that the largest massing move along the street level was associated with the garage entrance. In addition, Board members had concerns that the primary pedestrian entrance was too close in proximity to the garage entrance. The Board recommended the pedestrian access become more unified and requested studies for different entrance locations to better separate the pedestrian entrance from the garage access. This change in the lobby location would coincide with changes to the interaction with the lobby and amenity space. **(University Supplemental Guidance PL3.1.a)**
+ Response: The garage entrance was eliminated. There is no longer a vehicle garage proposed but a double height building entry on the south end of the street front. This access point proposes a 10' wide drive for occasional move-in / out needs. The access point on the south also serves as a means for people and bikes to enter the site. This leads to an open-air "sports court" for residents. Vehicle move-in / out will also happen in this location. The entrance for residents, bikes and move-in / out access has been separated from the access point to the trash and recycling room which remains on the north end of the street front in a similar fashion as the EDG 1 concept. **(Please see pp. 78-81; 95-96 for additional information)**

4. GROUND PLANE / SITE PLANNING (CONT.)

c. The Board generally supported the direction of the site landscaping, suggesting the applicant work with the Seattle Department of Transportation to increase the landscaping within the right-of-way, along the street between the sidewalk and dedicated bike lane. The Board supported the direction and intent of the landscaping along the west side of the project site. **(DC4.D)**

+ Response: Increased landscaping was introduced along the ROW by setting the street front further away from the street edge. Additional planting areas are proposed. **(Please see pp. 78,80,82 for additional information)**

4. GROUND PLANE / SITE PLANNING (CONT.)

d. The Board had concerns with the location of the bike parking access on the north side of the building, next to the garage entrance. The Board requested additional options for the bike parking access, suggesting it may be appropriate to group the bike parking access closer to or combined with the main entrance to the building. **(University Supplemental Guidance PL4.1)**
+ Response: Garage entry no longer proposed. Access for trash and recycling room is at the north edge. People, bikes and the main entry to the building is on the south end of the street front. Two access points for people and bikes proposed. Multiple locations for bike storage proposed. **(Please see pp. 78, 80-81 for additional information)**

EDG 1 BOARD DIRECTION

08 | EDG 2 RESPONSE

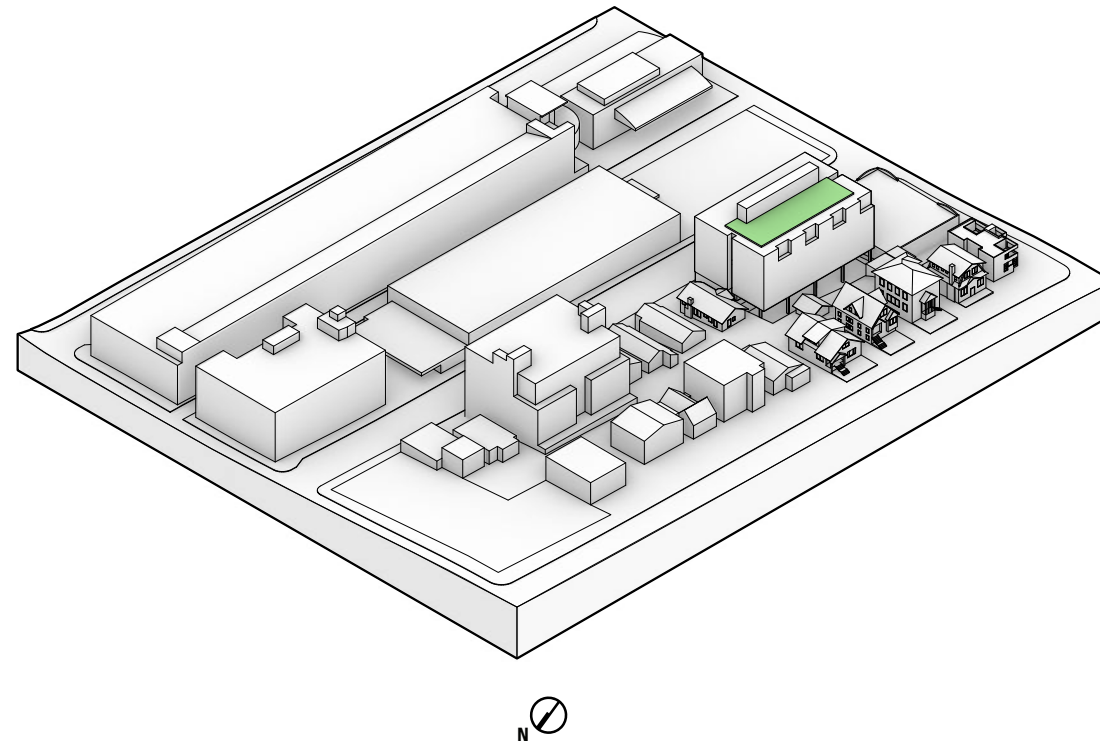
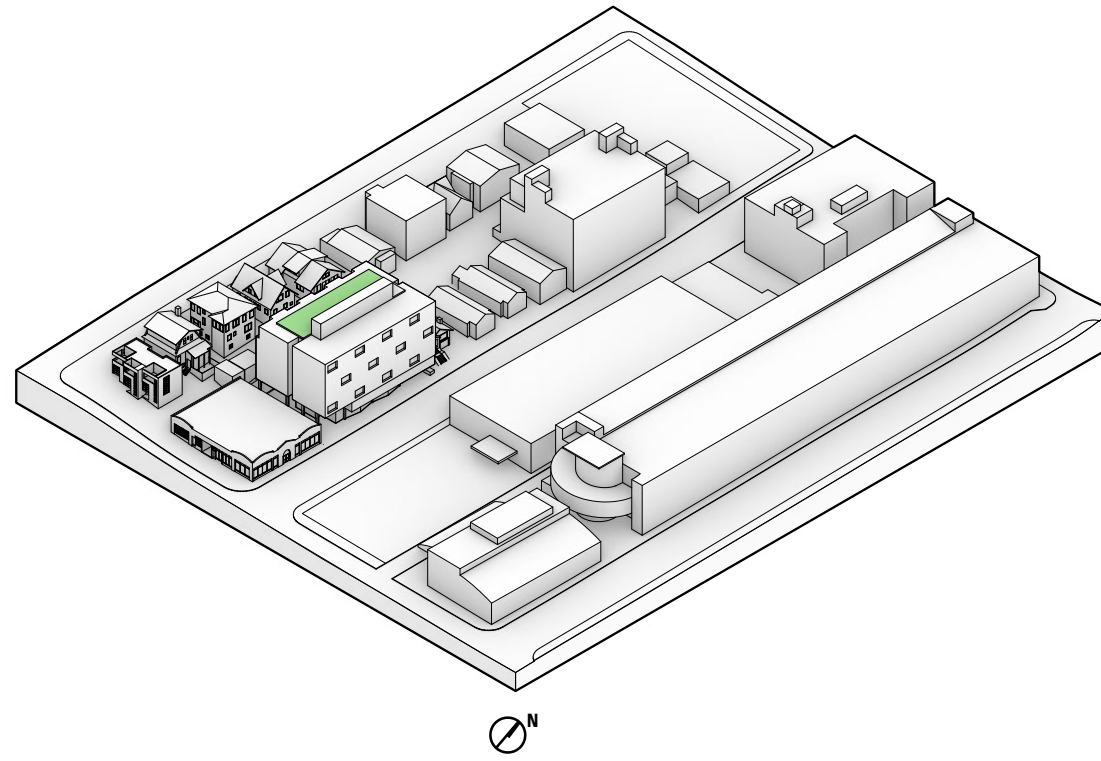

EDG 2 OVERVIEW

Opportunities

- Stronger relationship to the existing platting patterns and neighborhood context than previous concepts
- Maximized livable area by reconsidering parking, back of house space needs and street level uses.
- Introduces modulation on all four facades.
- Roof deck setback from all edges and elimination of patios at grade on the west to respect adjacent sites
- Overhead weather protection along Roosevelt Way NE
- Increased setback and planting along building edge at street level.
- Proposes potential to convert street level space to retail uses.
- Parking replaced with residential sport court and on-site move-in / out access
- No departure requests anticipated

Constraints

- No dedicated retail space initially proposed.
- No parking provided



View from Roosevelt Way NE Looking SW

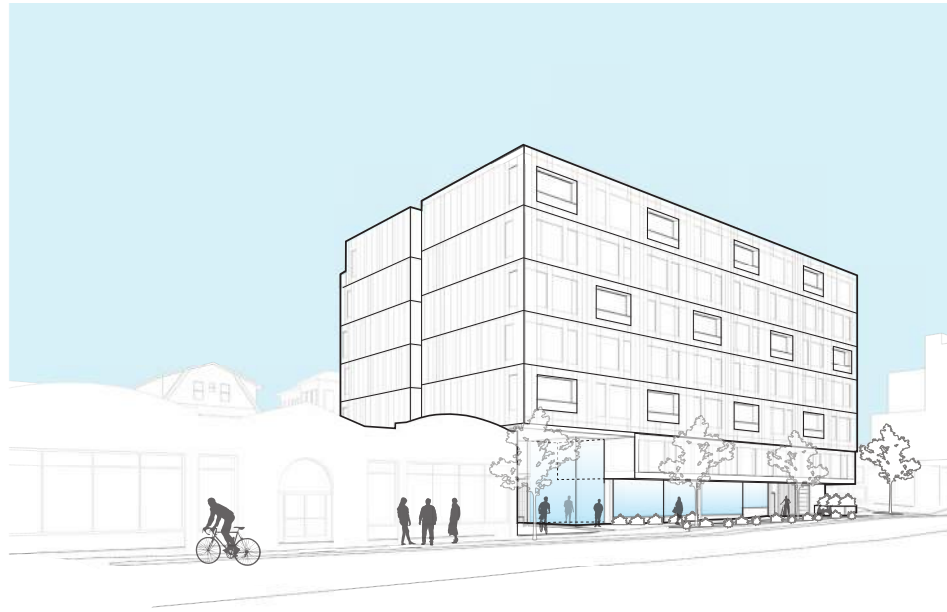

View from Roosevelt Way NE Looking NW



View from 9th Avenue NE Looking SE

EDG 2 MASSING OVERVIEW

09 | SITE CONTEXT & ANALYSIS

NE 50TH ST

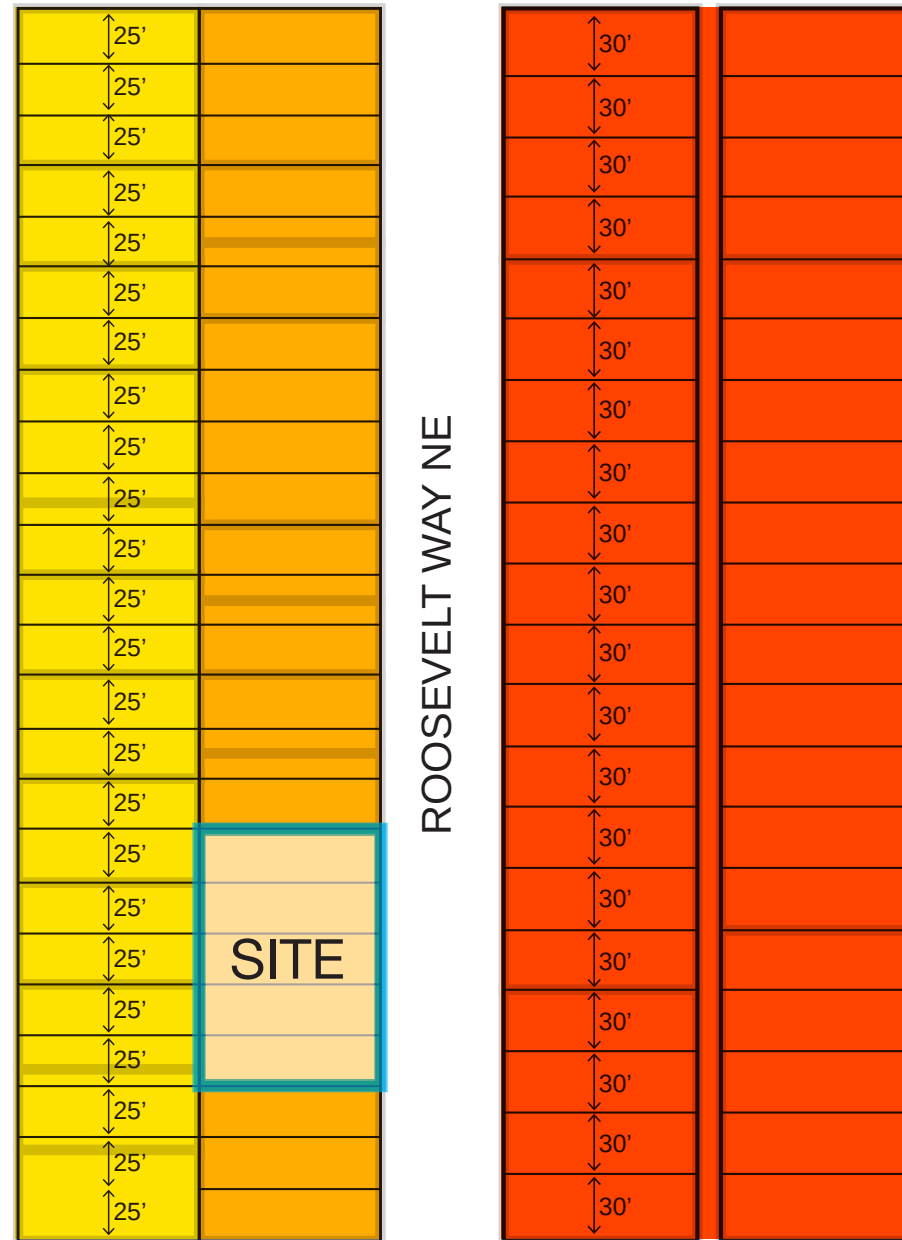

LR2 | NC3-65 | SMU-75/240

Less Intense Zoning



More Intense Zoning

ORIGINAL PLATTING TRANSITIONS

H

1. SITE CONTEXT AND ANALYSIS

DESIGN REVIEW BOARD DIRECTION:

a. The Board discussed the lack of information contained in the packet regarding the building design's response to context. The Board noted that the packet did not go far enough with the context analysis, which made it difficult to understand the dimensional relationship between the proposed building and the existing building. . . (CS2.B.1, CS2.C.2, University Supplemental Guidance – CS2.1.e, CS1.1.c, DC2.2.a)

2. MASSING

DESIGN REVIEW BOARD DIRECTION:

a. The Board stated Option 1 does not adequately respond to the context of the neighborhood, noting the lack of building articulation and the absence of 20' to 40' building modulation supported in the University Supplemental Design Guidelines. While the Board noted the vertical elevator in Option 2 provided a meaningful massing move, Option 2 lacked the balconies along Roosevelt to assist in breaking down the building mass. The Board stated that it was difficult to support a building massing design that lacked balconies on Roosevelt Ave. (University Supplemental Guidance – CS2.1.e, DC2.1.a)

DESIGN RESPONSE

+ On the diagram to the left shows the original platting of the proposal's block and the adjacent block to the east. Additionally the different zones are indicated. There is a correlation between the original widths of the block and the intensity of zoning. The 30' wide blocks to the east are zoned for mixed-use structures to 240'. The block west was platted originally with 25' wide lot widths. The zoning further reduces in intensity from the neighborhood commercial zone (NC3-65) to the LR2 zone. This block framework and zoning establishes a grid and plan arrangement for the proposal. (Please see pp. 53-57,86)

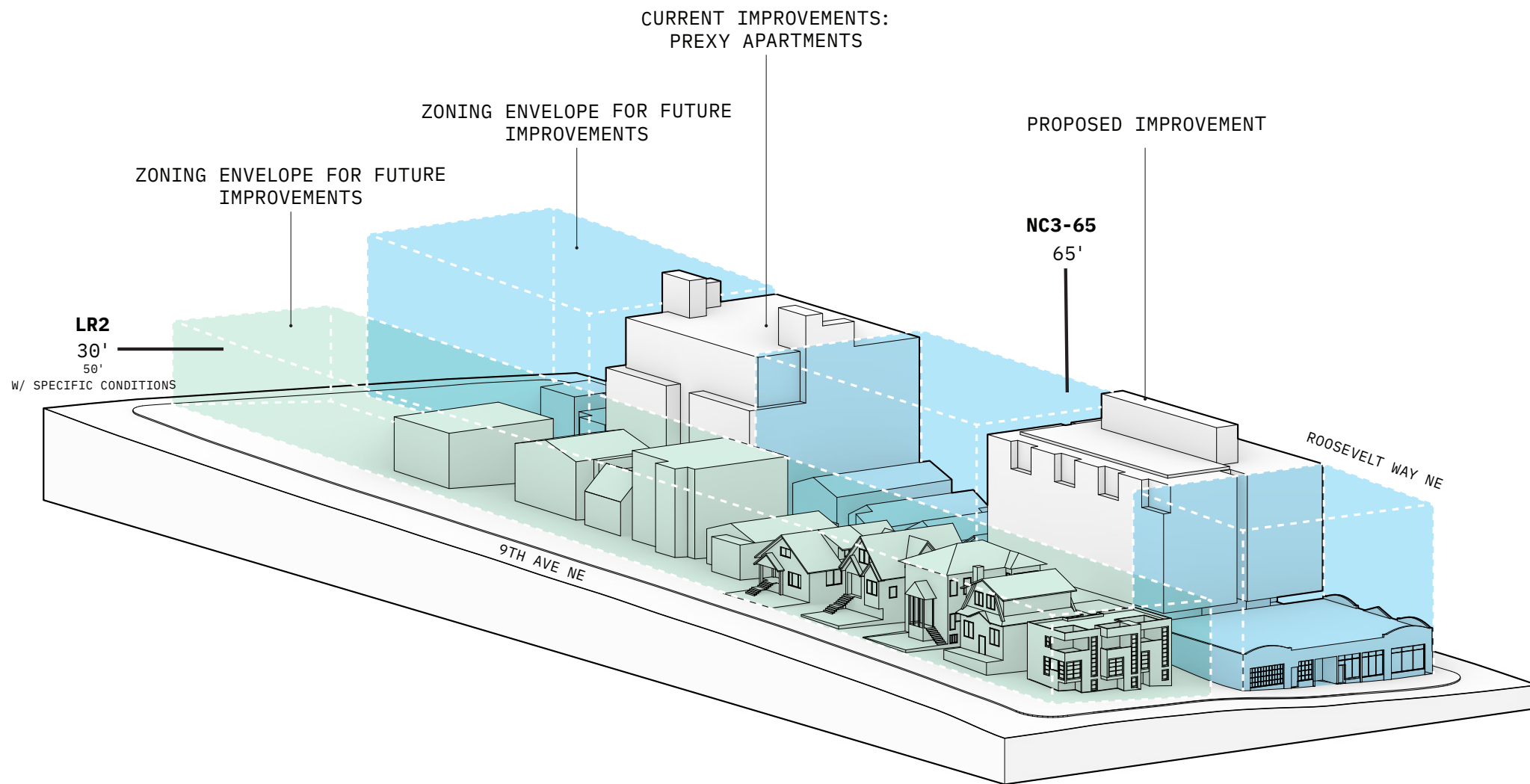

EXISTING AND POTENTIAL BLOCK IMPROVEMENTS



H

1. SITE CONTEXT AND ANALYSIS

DESIGN REVIEW BOARD DIRECTION:

a. The Board discussed the lack of information contained in the packet regarding the building design's response to context. The Board noted that the packet did not go far enough with the context analysis, which made it difficult to understand the dimensional relationship between the proposed building and the existing building. . . . (CS2.B.1, CS2.C.2, University Supplemental Guidance – CS2.1.e, CS1.1.c, DC2.2.a)

2. MASSING

DESIGN REVIEW BOARD DIRECTION:

a. The Board supported the 15' setback along the west property line shown in Options 1 and 2 with the building pushed closer to Roosevelt Ave. The Board supported the introduction of balconies on the west side of the building (shown in all three options) , noting that balconies provided an appropriate relationship with the adjacent single -family dwellings. However, the Board thought the introduction of balconies was not enough, noting the lack of modulation along the west façade. The Board requested the applicant further study ways to soften the western edge of the building and alleviate the 5-story façade. The Board suggested the applicant explore

DESIGN RESPONSE

+ The axonometric massing diagram indicates all but one structure on the block (Prexy Apartments) is under-improved. This suggested future conditions for the block could be very different than the current conditions. The lighter green and blue masses show the planned height bulk and scale the city intends for the block over time. The single family houses to the west are not in a single family zone but a multi-family zone - LR2. This is expressed by overlaying basic zoning parameters for the block. The neighborhood commercial zone to the east is planned for 65' high structures with little to no setbacks on the interior lot lines and a 10' setback on the rear lot line above 13'. The west, the LR2 zone is planned for 30' heights (50' under specific circumstances) and a 15' rear lot line setback. (Please see pp. 70-75)

10 | MASSING + FACADE CONCEPT



MIXED-USE RESIDENTIAL
 1302 NE Campus Pkwy Neighboring
 Poplar Hall



COMMERCIAL
 1901 Roosevelt Way NE
 Neighboring Commercial



APARTMENT BUILDING
 4541 Brooklyn Ave NE
 Apartment Building



CIVIC BUILDING
 1050 NE 50th St
 Seattle Fire Station 17

1. SITE CONTEXT AND ANALYSIS

DESIGN REVIEW BOARD DIRECTION:

a. The Board discussed the lack of information contained in the packet regarding the building design's response to context. The Board noted that the packet did not go far enough with the context analysis, which made it difficult to understand the dimensional relationship between the proposed building and the existing building. The Board requested the applicant consider the existing building's relationship to the proposed building and how that could impact the north and south facades. The Board noted that the property immediately north of the project site is likely to be redeveloped due to the Existing underdeveloped nature of the site currently. However, the Board suggested the south facade of the building could be visibly prominent for years due to the existing building immediately south of the project site. The Board supported the use of balconies shown in Option 3 stating that this component was responsive to the existing context in the neighborhood. **(CS2.B.1, CS2.C.2, University Supplemental Guidance – CS2.1.e, CS1.1.c, DC2.2.a)**

Response: As part of our board directed site and context analysis, to the left are neighborhood examples of "fabric buildings" in the neighborhood. "Fabric" meaning they are part of the everyday street grid and blocks of the neighborhood. The buildings and facades are simple in massing and form. The window patterns express the needs of each of the uses. The overall expression of each is understated.

U DISTRICT "FABRIC BUILDINGS" PRECEDENTS

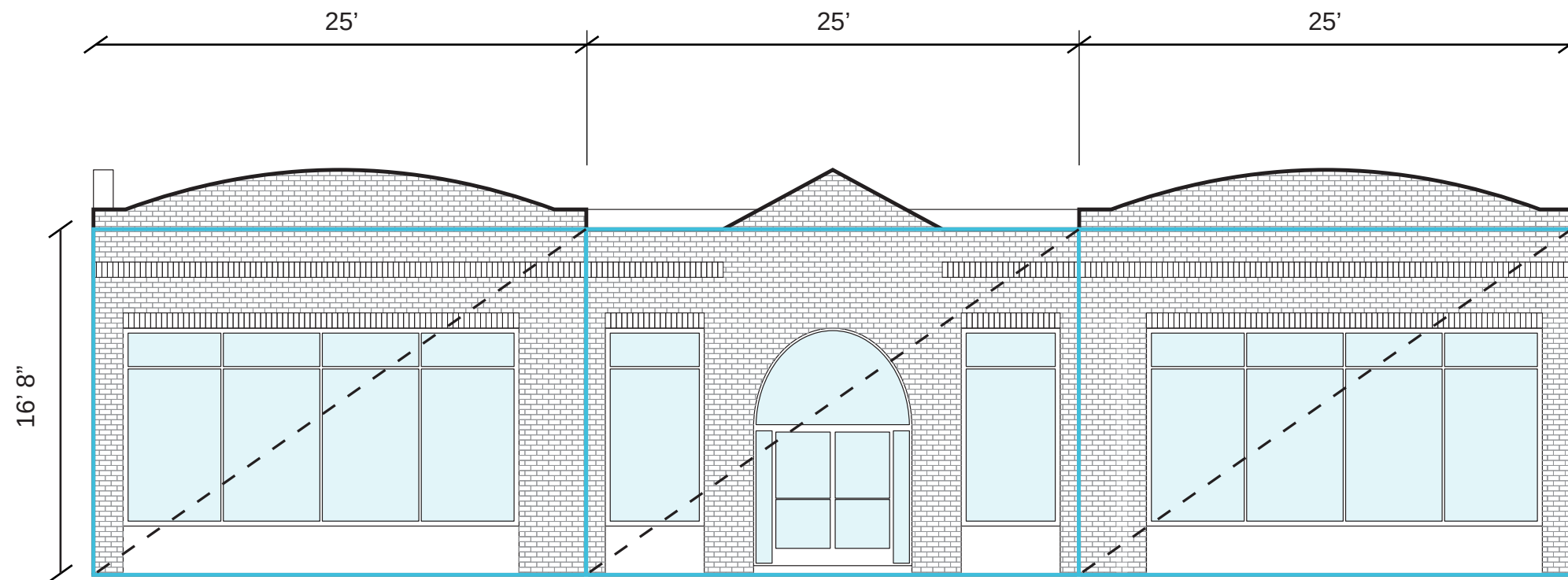

1. SITE CONTEXT AND ANALYSIS

DESIGN REVIEW BOARD DIRECTION:

a. The Board discussed the lack of information contained in the packet regarding the building design's response to context. The Board noted that the packet did not go far enough with the context analysis, which made it difficult to understand the dimensional relationship between the proposed building and the existing building. The Board requested the applicant consider the existing building's relationship to the proposed building and how that could impact the north and south facades. The Board noted that the property immediately north of the project site is likely to be redeveloped due to the Existing underdeveloped nature of the site currently. However, the Board suggested the south facade of the building could be visibly prominent for years due to the existing building immediately south of the project site. The Board supported the use of balconies shown in Option 3 stating that this component was responsive to the existing context in the neighborhood. (CS2.B.1, CS2.C.2, University Supplemental Guidance – CS2.1.e,

Response: A study of the adjacent commercial building revealed a width and proportion that reflects the urban grain of the block. Please see the following page that illustrates how the existing platting geometry and proportions of the context informed the plan arrangement, massing and fenestration of the proposed.

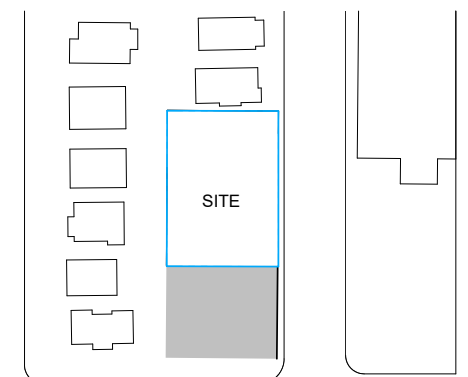

NEIGHBORING PROPORTIONS AND GEOMETRY

1. SITE CONTEXT AND ANALYSIS

DESIGN REVIEW BOARD DIRECTION:

a. The Board discussed the lack of information contained in the packet regarding the building design's response to context. The Board noted that the packet did not go far enough with the context analysis, which made it difficult to understand the dimensional relationship between the proposed building and the existing building. The Board requested the applicant consider the existing building's relationship to the proposed building and how that could impact the north and south facades. The Board noted that the property immediately north of the project site is likely to be redeveloped due to the Existing underdeveloped nature of the site currently. However, the Board suggested the south facade of the building could be visibly prominent for years due to the existing building immediately south of the project site. The Board supported the use of balconies shown in Option 3 stating that this component was responsive to the existing context in the neighborhood. (CS2.B.1, CS2.C.2, University Supplemental Guidance – CS2.1.e,

Response: To the left is an overlay of the existing commercial structure's 25' wide module superimposed with the module of the proposed apartment building. Please see the following pages for additional information depicting how the context informed the proposal's massing and facade concept.

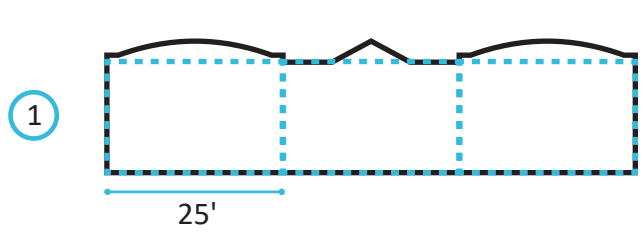
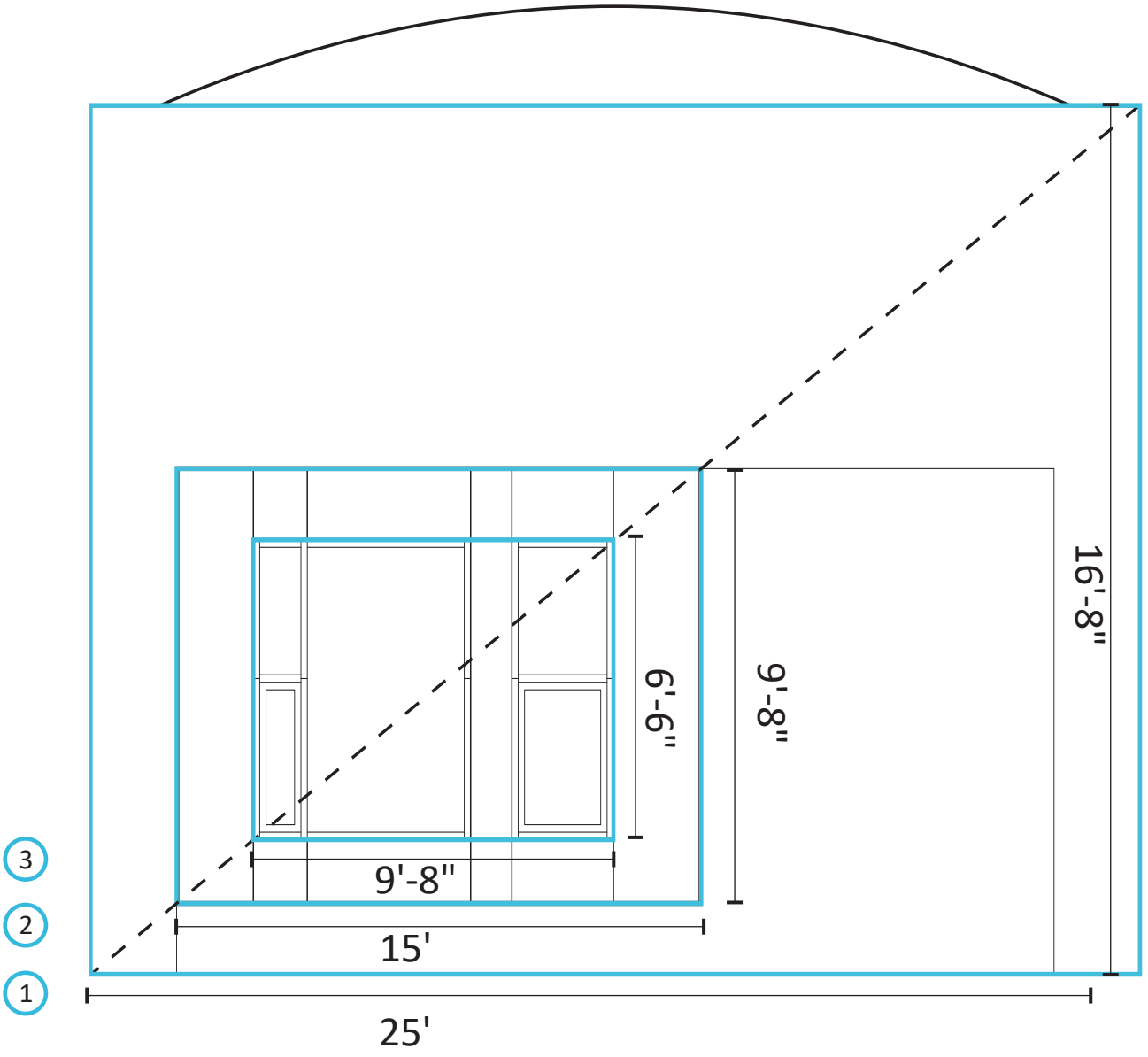

Module of existing commercial building reflecting the urban grain of the block and establishing a 1.5 +/- ratio of width to height

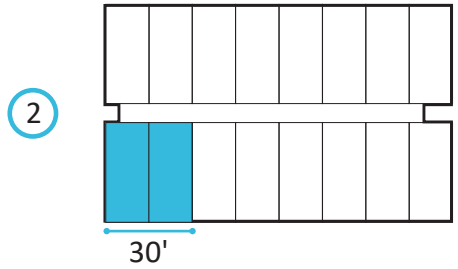

Module of proposed apartment building on a 30' column bay further subdivided into 15' wide apartments; 15' x 9'-8" matches the proportions of the existing the 1.5 +/- ratio of the existing commercial building

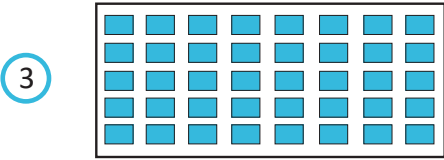

A fenestration pattern of 9'-8" wide x 6'-6" high matches the proportions of the existing the 1.5 +/- ratio of the existing commercial building to express the existing platting patterns and proportions of its context.

BLOCK PROPORTIONS TRANSLATED INTO FACADE

1. SITE CONTEXT AND ANALYSIS

DESIGN REVIEW BOARD DIRECTION:

- a. The Board discussed the lack of information contained in the packet regarding the building design's response to context. The Board noted that the packet did not go far enough with the context analysis, which made it difficult to understand the dimensional relationship between the proposed building and the existing building. . . (CS2.B.1, CS2.C.2, University Supplemental Guidance - CS2.1.e, CS1.1.c, DC2.2.a)

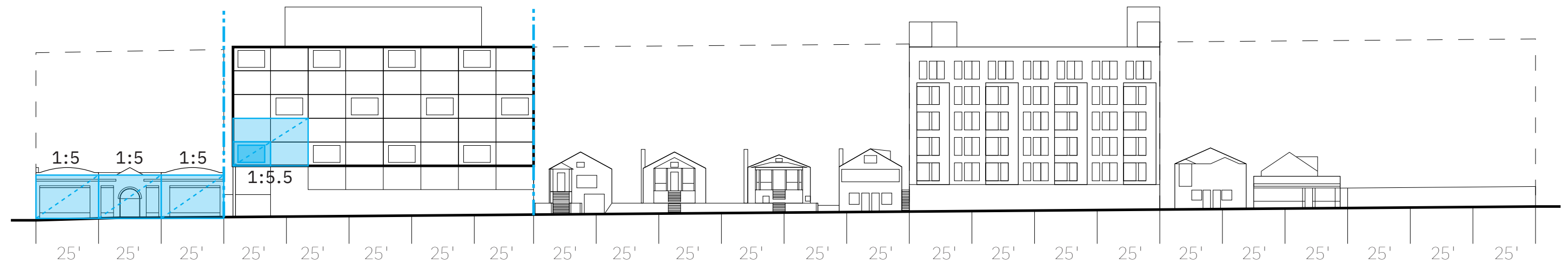

The existing urban grain and platting pattern translated into a 1:5 +/- proportion in the facade and compared to the existing conditions across the block.

PROPORTIONS OF THE CONTEXT TRANSLATE INTO THE
DIMENSIONS OF THE UNITS

1. SITE CONTEXT AND ANALYSIS

DESIGN REVIEW BOARD DIRECTION:

- a. The Board discussed the lack of information contained in the packet regarding the building design's response to context. The Board noted that the packet did not go far enough with the context analysis, which made it difficult to understand the dimensional relationship between the proposed building and the existing building. . . (CS2.B.1, CS2.C.2, University Supplemental Guidance – CS2.1.e, CS1.1.c, DC2.2.a)

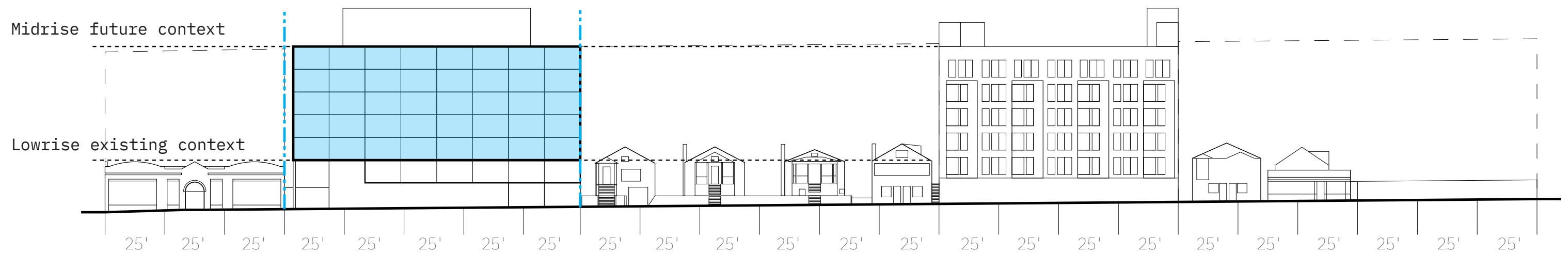

The proposed massing is horizontally divided. The upper apartment block or "block scale" apartments" expresses the intention of the NC3 zone and future development expectations for the block. The massing of the street level building elements setback from the massing above to create a datum that recognizes the smaller scale existing context.

EXISTING AND FUTURE DATUMS DIVIDE THE MASSING

1. SITE CONTEXT AND ANALYSIS

DESIGN REVIEW BOARD DIRECTION:

- a. The Board discussed the lack of information contained in the packet regarding the building design's response to context. The Board noted that the packet did not go far enough with the context analysis, which made it difficult to understand the dimensional relationship between the proposed building and the existing building. . . (CS2.B.1, CS2.C.2, University Supplemental Guidance - CS2.1.e, CS1.1.c, DC2.2.a)

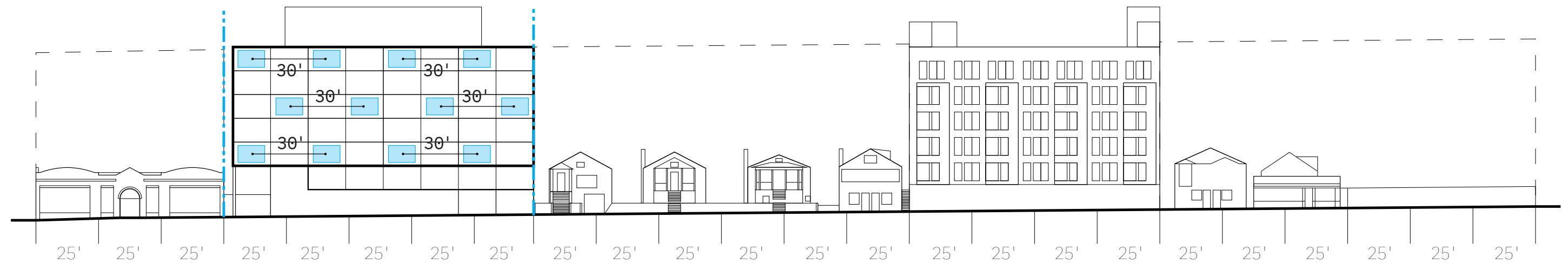

The upper massing or "Block Scale" apartments proposes 12 recessed Juliette depth balconies. The balconies are recessed portions of the grid of the same module and proportion as explained on page 51. Facade movement and interest and a recognition of a 20'-40' urban grain is gained by offsetting and alternating the recesses in the grid

GRAIN OF THE BLOCK INFORMS THE TEXTURE OF THE
FACADE

1. SITE CONTEXT AND ANALYSIS

DESIGN REVIEW BOARD DIRECTION:

a. The Board discussed the lack of information contained in the packet regarding the building design's response to context. The Board noted that the packet did not go far enough with the context analysis, which made it difficult to understand the dimensional relationship between the proposed building and the existing building. . . (CS2.B.1, CS2.C.2, University Supplemental Guidance - CS2.1.e, CS1.1.c, DC2.2.a)

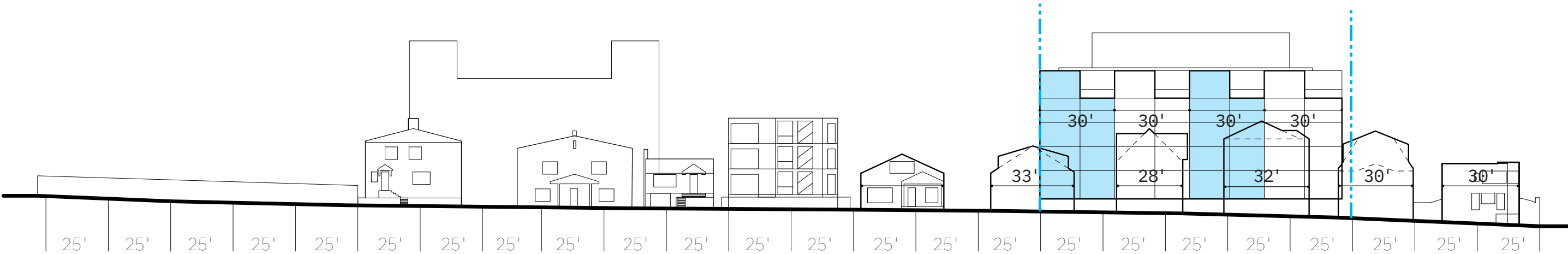

The upper massing or "Block Scale" apartments proposes 4 recessed occupied terraces on level 06. The balconies are recessed portions of the grid of the same module and proportion as explained on page 51. Facade movement and interest and a recognition of a 20'-40' urban grain is gained by offsetting and alternating the recesses in the grid.

WEST ELEVATION SCALE INFORMED BY LOW-RISE NEIGHBORS

1. SITE CONTEXT AND ANALYSIS

DESIGN REVIEW BOARD DIRECTION:

a. The Board discussed the lack of information contained in the packet regarding the building design's response to context. The Board noted that the packet did not go far enough with the context analysis, which made it difficult to understand the dimensional relationship between the proposed building and the existing building. . . (CS2.B.1, CS2.C.2, University Supplemental Guidance - CS2.1.e, CS1.1.c, DC2.2.a)

Steps down at south towards lowrise neighbors

Steps back at roof terminus

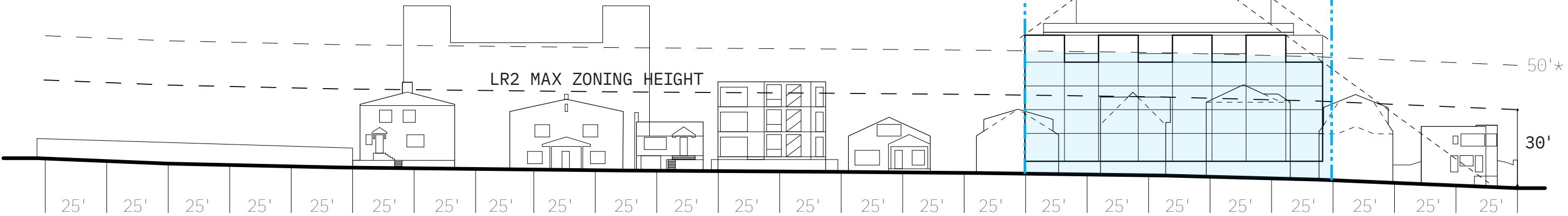

MASSING STEPS DOWN TOWARDS LOW-RISE NEIGHBORS

1. SITE CONTEXT AND ANALYSIS

DESIGN REVIEW BOARD DIRECTION:

- a. The Board discussed the lack of information contained in the packet regarding the building design's response to context. The Board noted that the packet did not go far enough with the context analysis, which made it difficult to understand the dimensional relationship between the proposed building and the existing building. . . (CS2.B.1, CS2.C.2, University Supplemental Guidance – CS2.1.e, CS1.1.c, DC2.2.a)

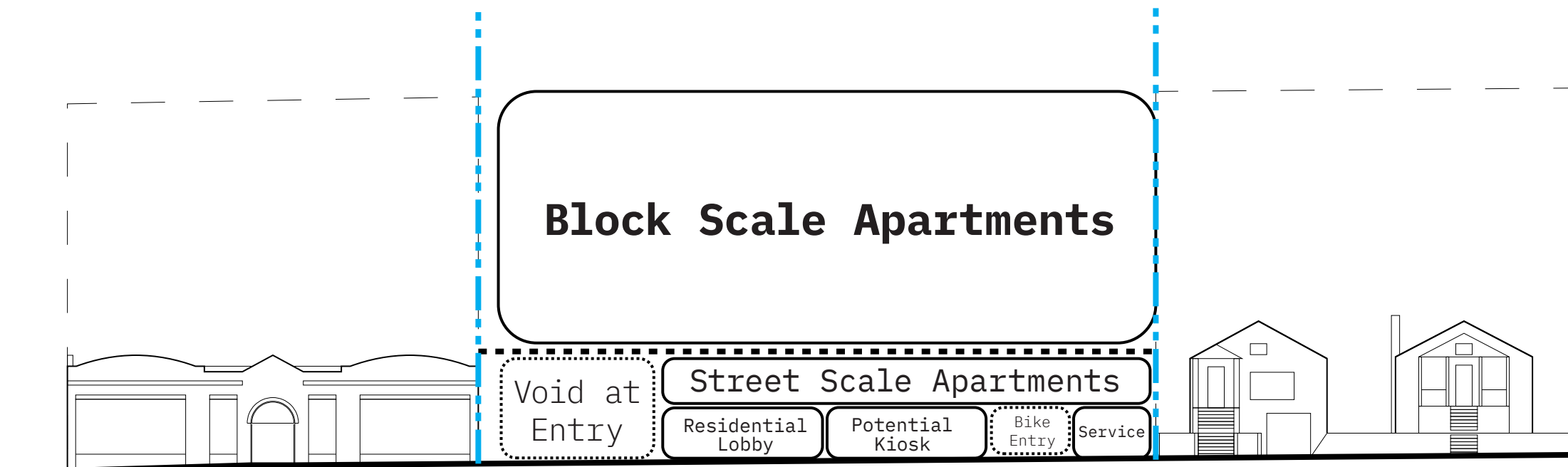

BUILDING USE REFLECTED IN THE ELEVATION

Block Scale Apartments

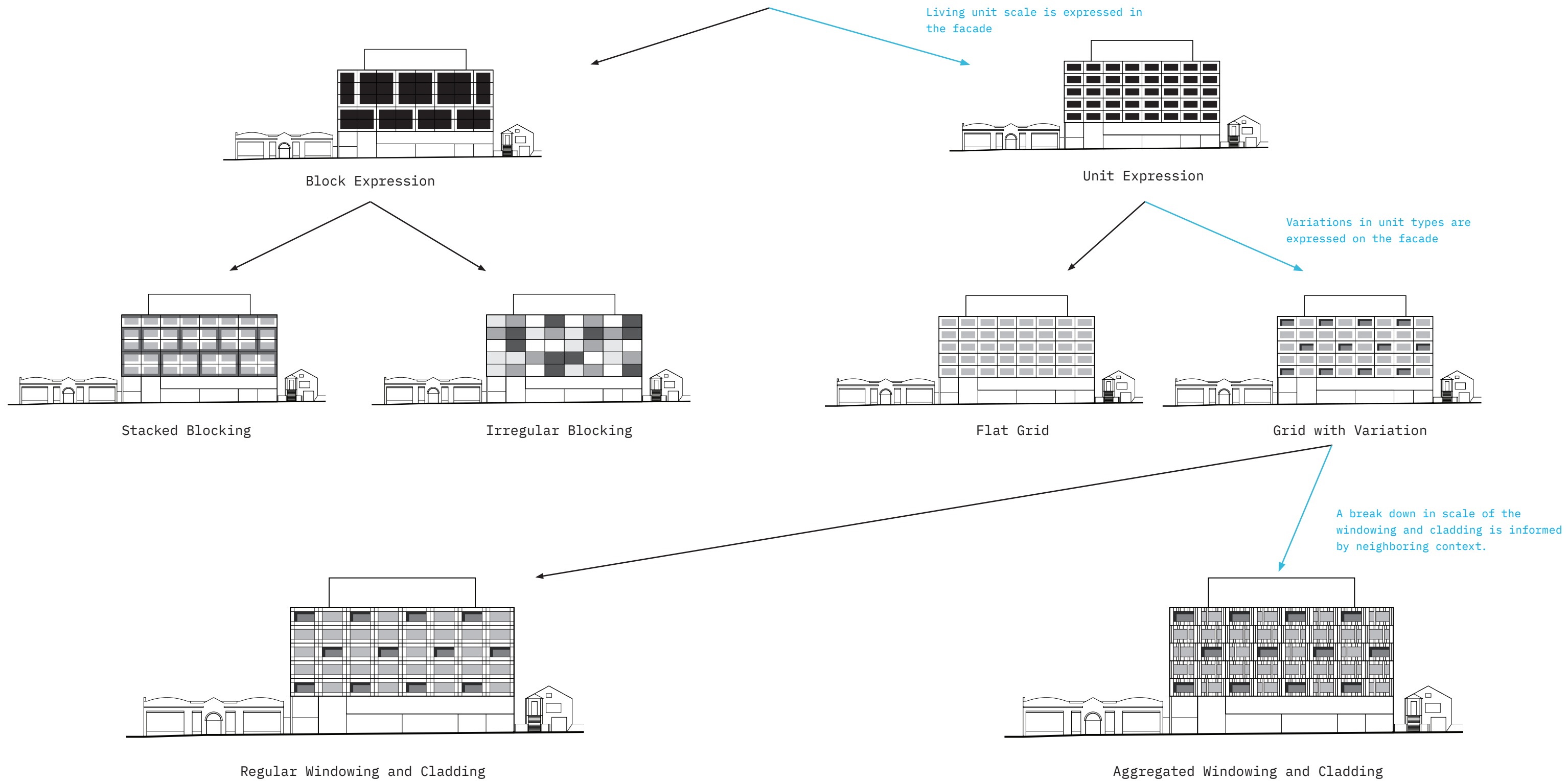

FACADE MATRIX



Site context and analysis informing the east facade; Recessed Juliette balconies at 30' intervals reflecting historic platting patterns; larger prominent entry adding deference to the existing commercial building to the south; smaller scale street level; increased setbacks from the ROW; porous openings through the site

CS2.B.1 SITE CHARACTERISTICS

CS2.C.2 MID-BLOCK SITES

UDSG - CS2.1.e.1 REFLECT HISTORIC PLATTING PATTERNS

UDSG - PL3.1.a PROMINENT ENTRIES

UDSG - DC2.2.a EMBRACE CONTEMPORARY DESIGN

EAST FACADE CONCEPT | VIEW FROM ROOSEVELT WAY NE

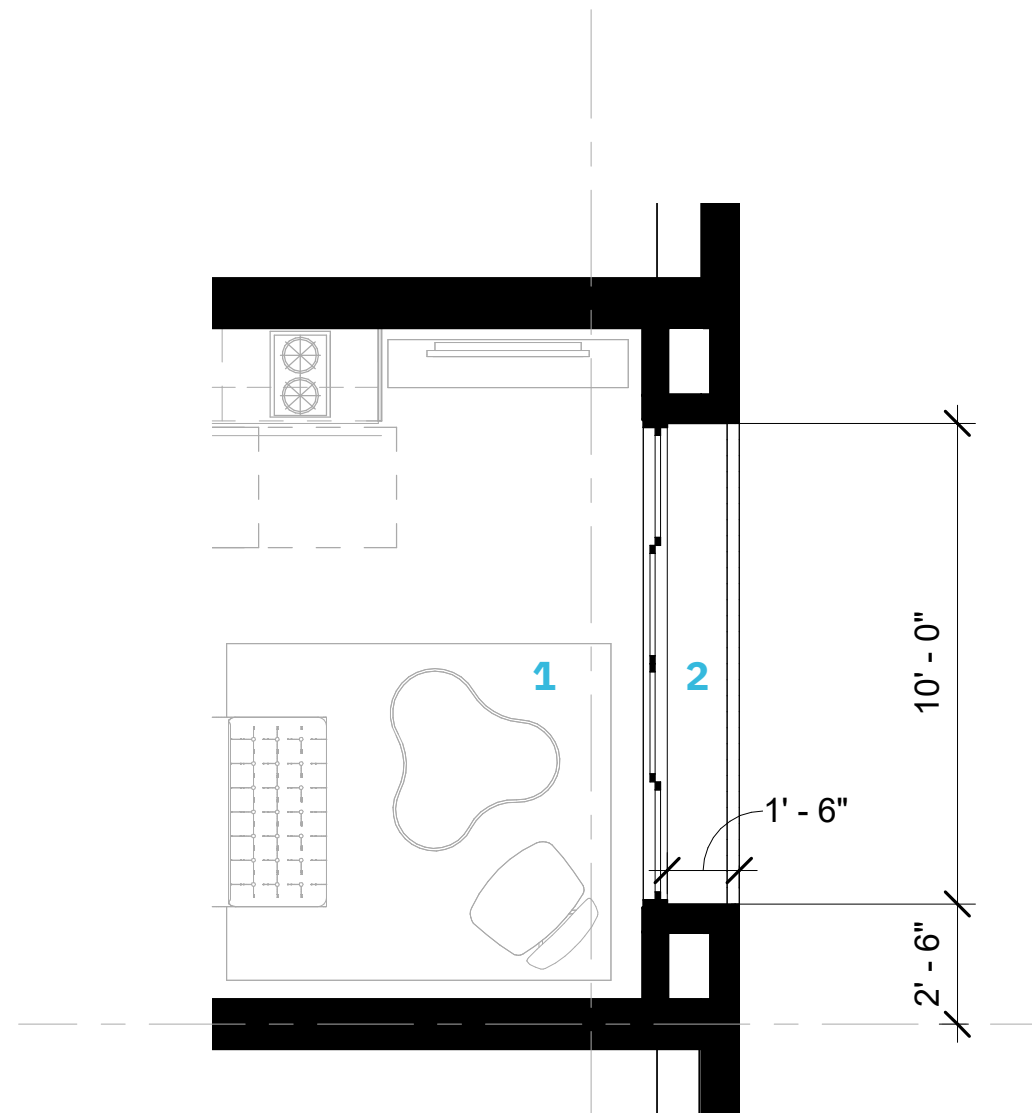

- 1. UNIT INTERIOR
- 2. JULIETTE BALCONY

EAST FACADE | INSET JULIETTE BALCONY PLAN

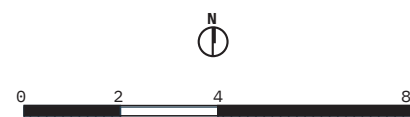

H

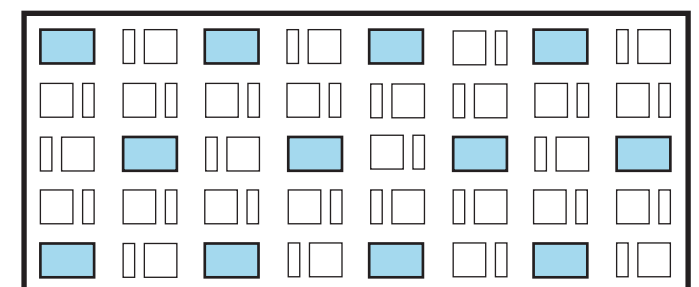

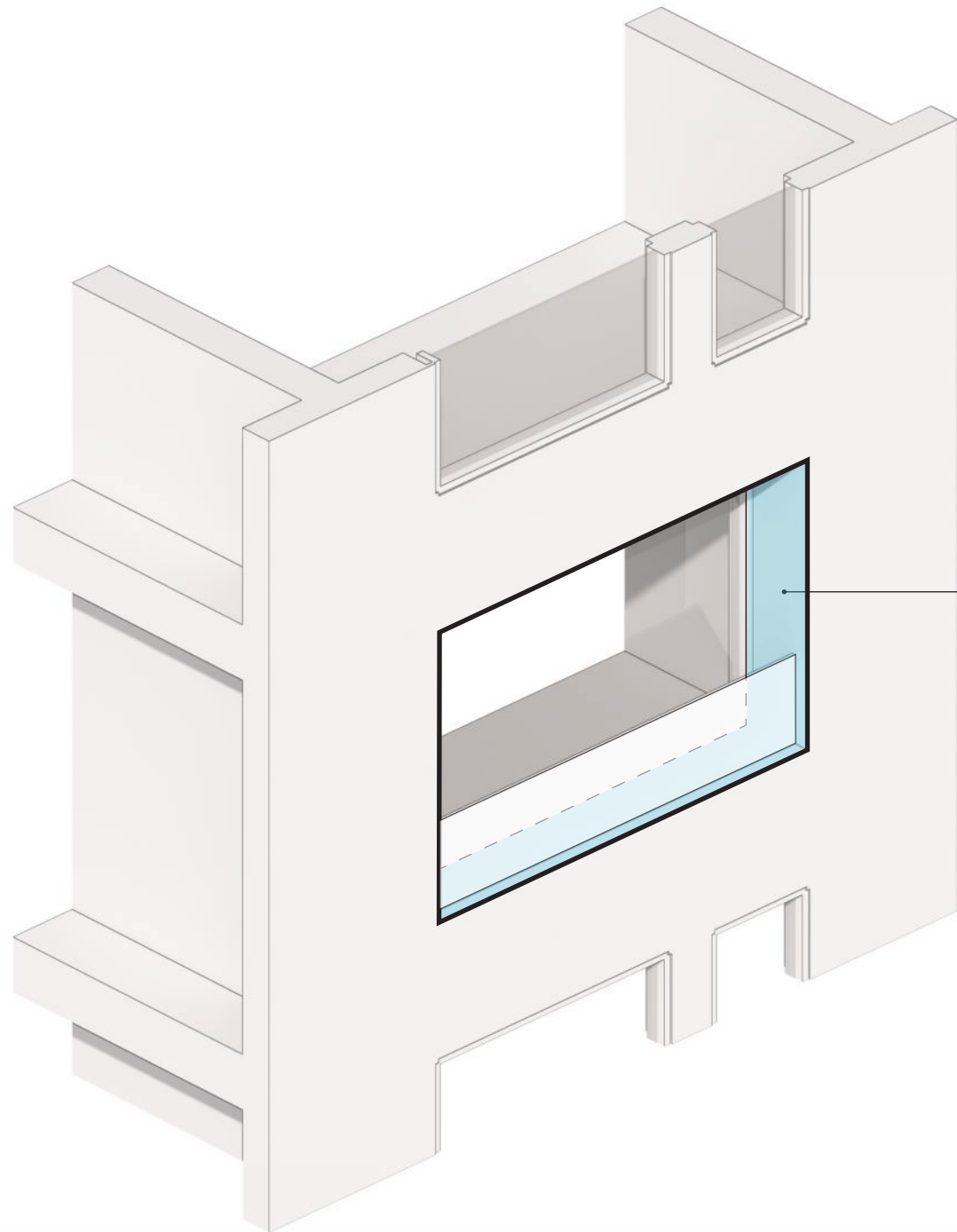

1'-6" INSET ON EAST FACADE

EAST FACADE INSET | TYPICAL PARTIAL AXON

Ø^N

H

62

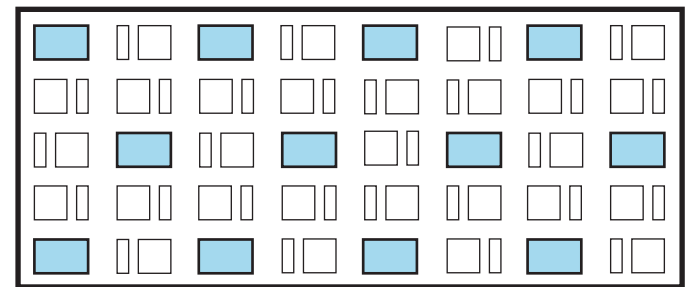

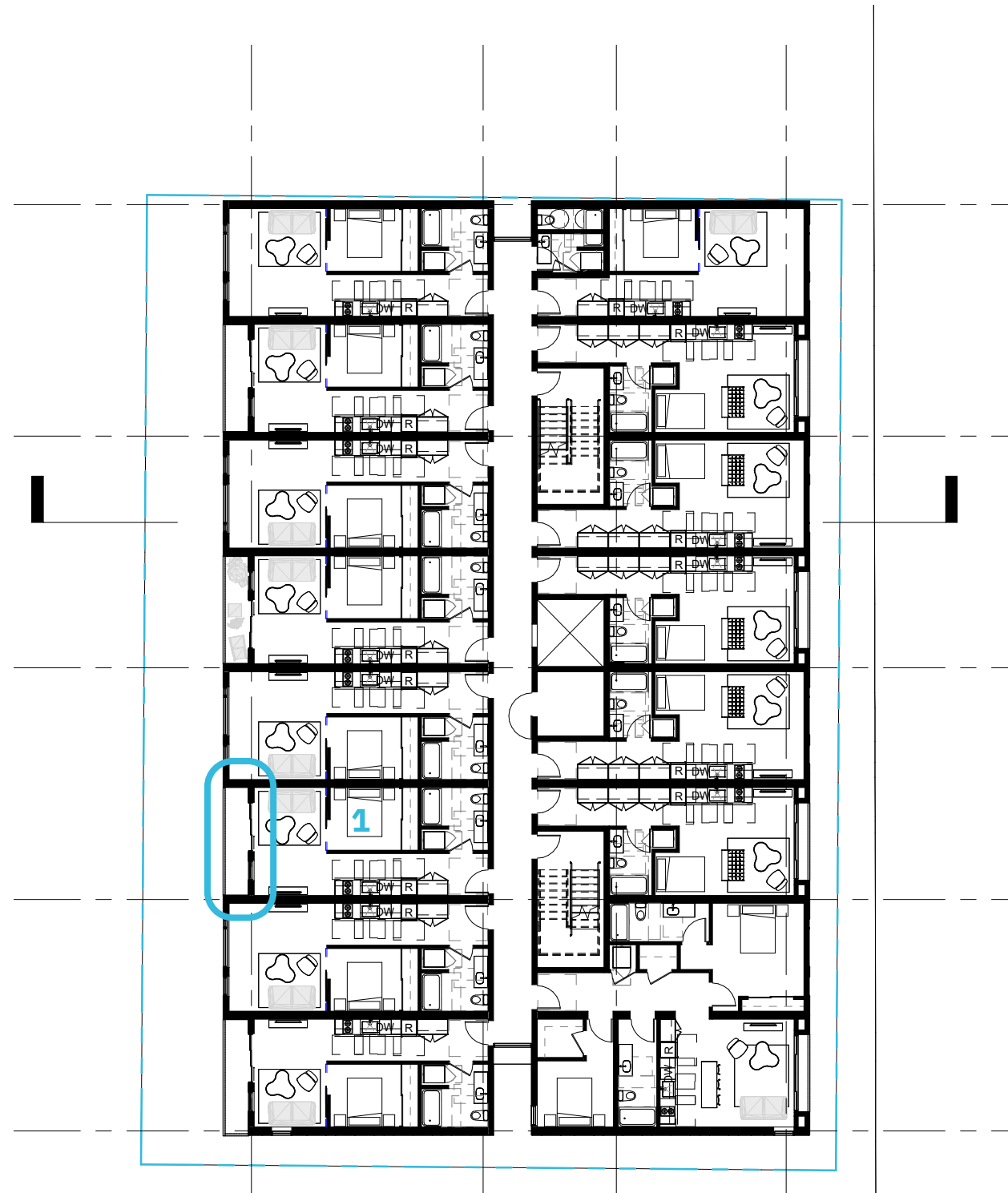

- 1. 2BD UNIT
- 2. URBAN 1 BED UNIT

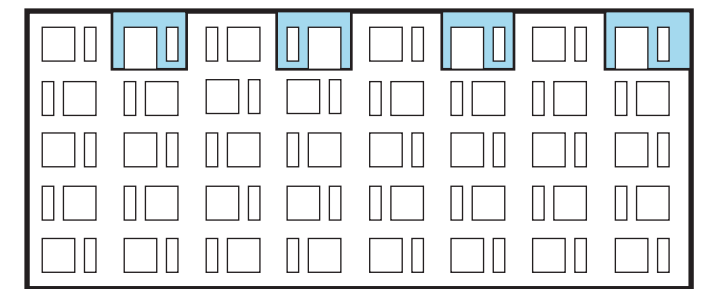

L06 PLAN

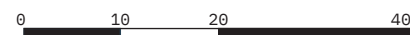

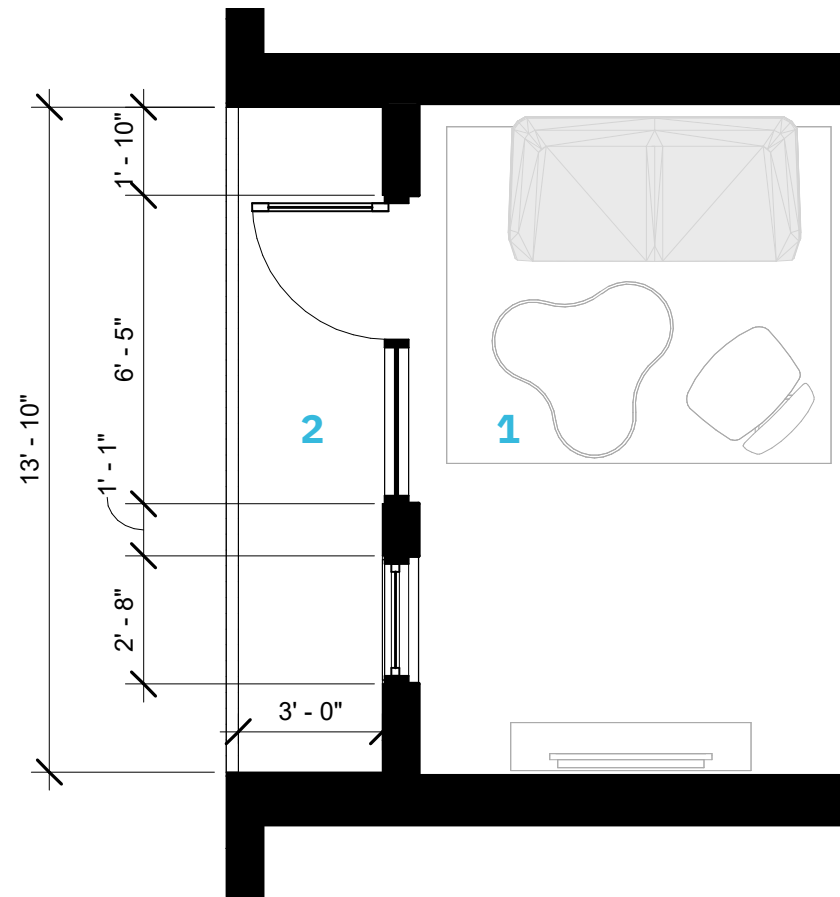

INSET BALCONY PLAN

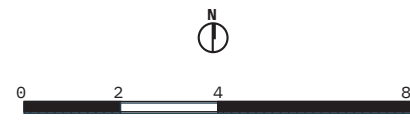

- 1. UNIT INTERIOR
- 2. EXTERIOR BALCONY

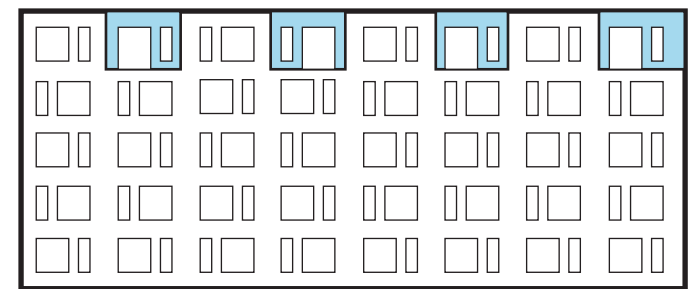

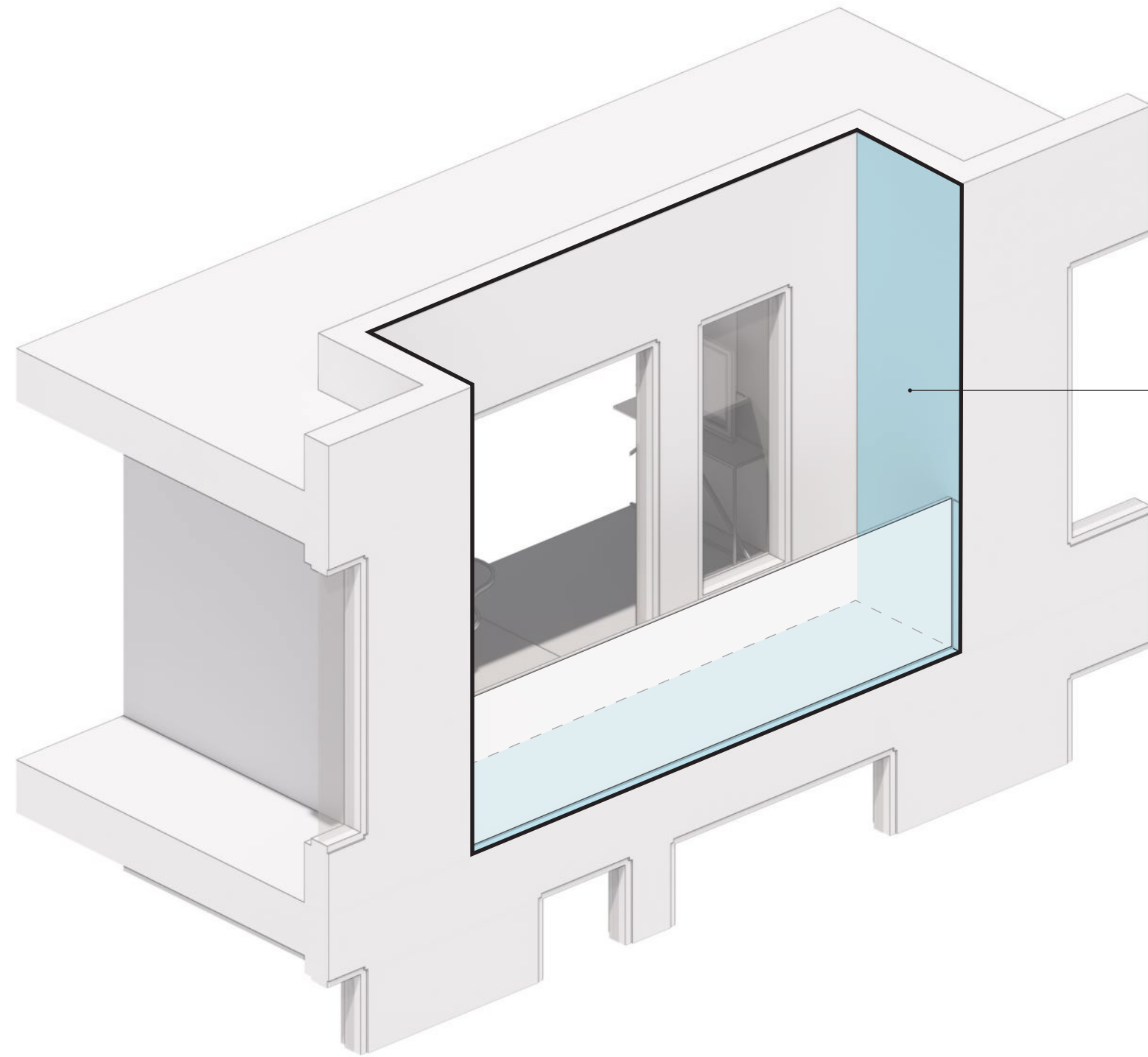

3' INSET ON WEST FACADE

INSET BALCONY ON WEST FACADE

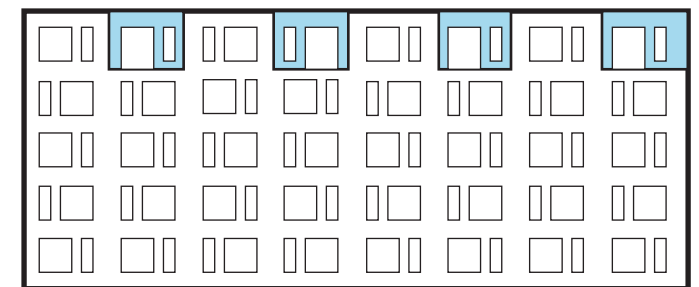

11 | INTERIOR LOT LINE FACADE CONCEPT

Art

Enhancing the blank facades with artwork



12th Ave. & 50th St.



12th Ave. & 50th St.



4507 Brooklyn Ave. N.E

Green

Adding vegetation to soften sections of blank facades



Relief

Subtle changes in patterns and relief in the facade to create an artistic expression



Material

Compatible variation of the interior facades materials relative to the east and west facade to provide a cohesive facade concept

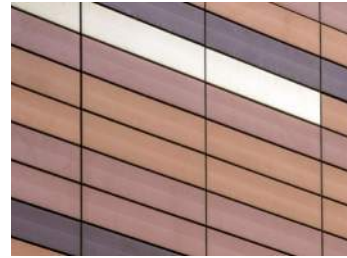

Architectural

Well-placed accent breaks in the walls along with providing opportunities for glazing to add interest and variety



2. MASSING - INTERIOR LOT LINE FACADE

DESIGN REVIEW BOARD DIRECTION:

b. The Board was concerned with the lack of modulation on the building's south façade, noting their previous comment regarding the likelihood of this façade being visually prominent for years to come. The Board suggested more articulation along the south façade would be appropriate. (University Supplemental Guidance – CS2.1.e, DC2.B.2)

Response: The project's interior facade design considered several means to enhance facades that are temporarily visible due to the adjacent underdeveloped buildings. The goal for the interior facades is to add interest and variety while acknowledging the facades may not be visible once the adjacent properties are developed to the same intensity of the proposed. The highlighted options "Material" and "Architectural" are two strategies proposed. By selecting a consistent, material appropriate for all sides of the building and adding variation could promote a cohesive design. Breaking the interior facades into two sections and introducing limited amounts of glazing would reduce the scale and add interest.

Please see the following page for a study matrix of the interior lot line facade options.

INTERIOR LOT LINE FACADE CONCEPT OPTIONS

Interior Lot Line Facades

North & South

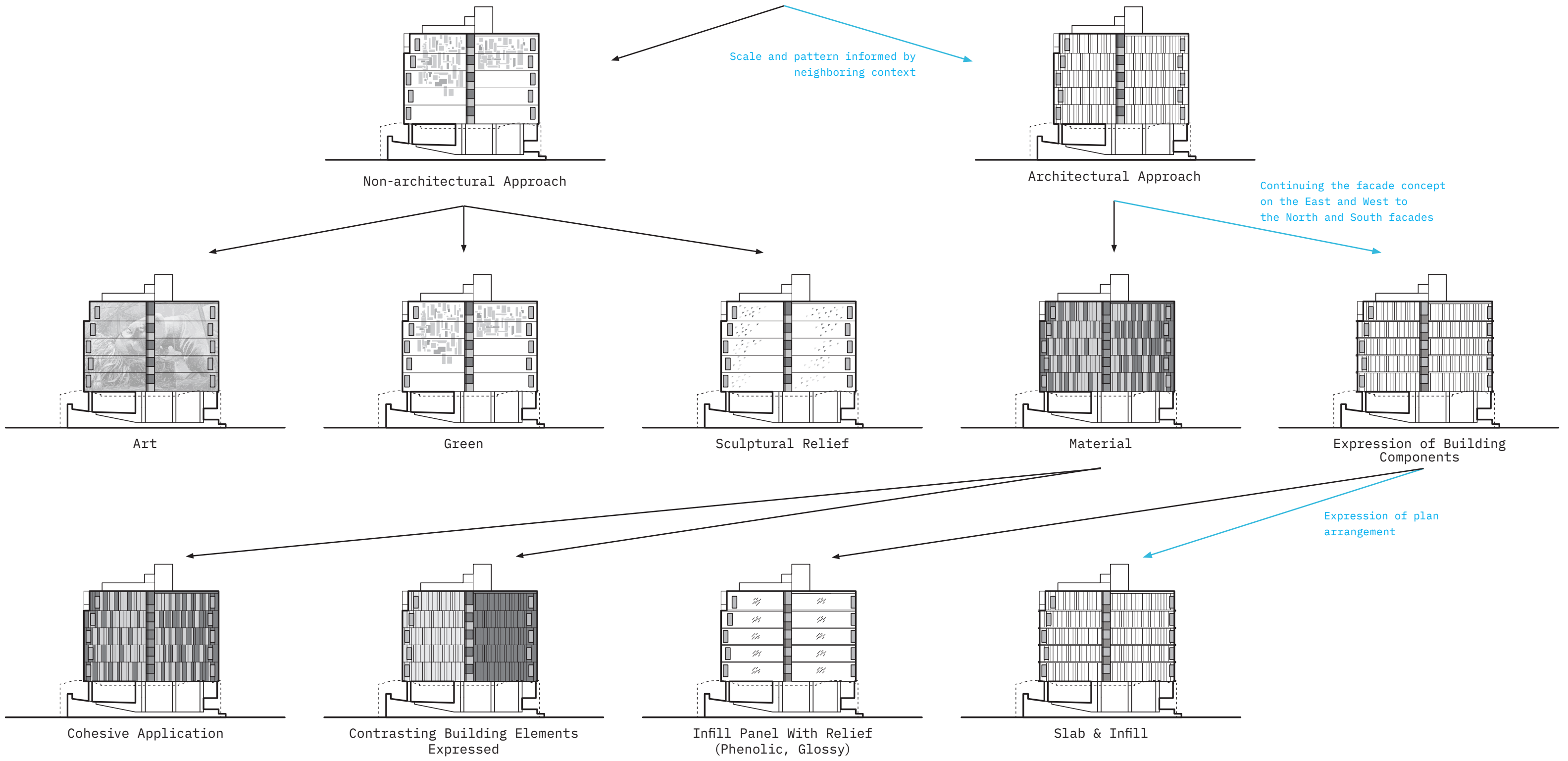

INTERIOR LOT LINE FACADE MATRIX

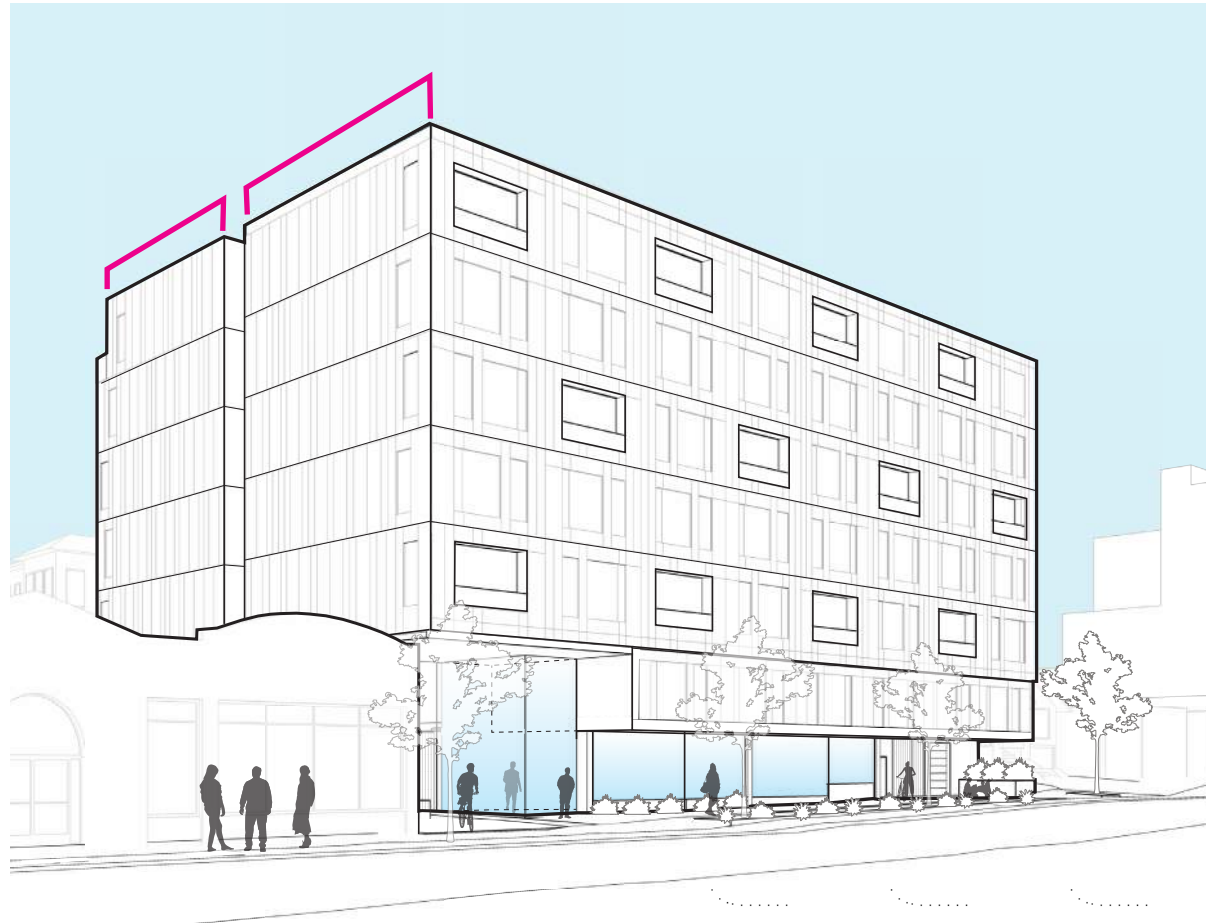

Building shifted to the north allowing glazing at the corners of the south facade

Material selection proposes to be appropriate for all facades to create a simple, cohesive design concept.

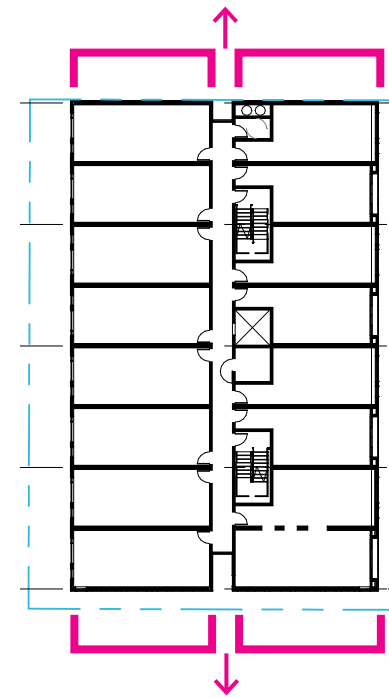

Double loaded corridor expressed on the north and south facades with a notch and glazing.

2. MASSING - INTERIOR LOT LINE FACADE

DESIGN REVIEW BOARD DIRECTION:

b. The Board was concerned with the lack of modulation on the building's south façade, noting their previous comment regarding the likelihood of this façade being visually prominent for years to come. The Board suggested more articulation along the south façade would be appropriate. (**University Supplemental Guidance – CS2.1.e, DC2.B.2**)

Response: The EDG 2 alternative breaks the interior lot line walls into two sections to express the double loaded plan arrangement. The north and south notches are proposed to have windows allowing daylight into the interior and add interest to the interior facades. The EDG 2 Alternative also shifts the building north to allow some separation of the south facade from the interior lot line. This allows for small amounts of corner glazing on the south wall and reduce the blank wall effect.

INTERIOR LOT LINE FACADE CONCEPT

12 | ZONE TRANSITION

3. ZONE TRANSITION

DESIGN REVIEW BOARD DIRECTION:

a. The Board supported the 15' setback along the west property line shown in Options 1 and 2 with the building pushed closer to Roosevelt Ave. The Board supported the introduction of balconies on the west side of the building (shown in all three options), noting that balconies provided an appropriate relationship with the adjacent single-family dwellings. However, the Board thought the introduction of balconies was not enough, noting the lack of modulation along the west façade. The Board requested the applicant further study ways to soften the western edge of the building and alleviate the 5-story façade. The Board suggested the applicant explore deepening the balconies, creating more of a statement along this façade. **(DC2.C, University Supplemental Guidance CS2.2.b, DC2.2.i)**

Response: In addition to the City-wide and Neighborhood guidelines cited above, to the left is another relevant City-wide design guideline that informed the design direction for the EDG 2 proposal. Please see the following pages for the EDG 2 response to the Board's direction regarding the zone transition to the west of the site.

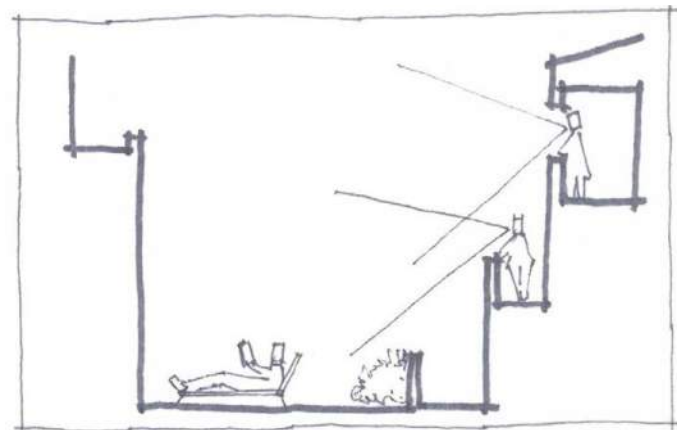

Inappropriate siting of large buildings can reduce the privacy of adjacent homes. Reducing windows and decks overlooking neighboring residential property or increasing side setbacks can increase privacy.

CS2 - D 03

Zone Transitions: For projects located at the edge of different zones, provide an appropriate transition or complement to the adjacent zone(s). Projects should create a step in perceived height, bulk and scale between the anticipated development potential of the adjacent zone and the proposed development.

Factors to consider:

- Distance to the edge of a less (or more) intensive zone;
- Differences in development standards between abutting zones;
- The type of separation from adjacent properties (e.g. separation by property line only, by an alley or street or open space, or by physical features such as grade change);
- Adjacencies to different neighborhoods or districts; adjacencies to parks, open spaces, significant buildings or view corridors; and
- Shading to or from neighboring properties.

CS2 - D 04

Massing Choices: Strive for a successful transition between zones where a project abuts a less intense zone. In some areas, the best approach may be to lower the building height, break up the mass of the building, and/or match the scale of adjacent properties in building detailing. It may be appropriate in other areas to differ from the scale of adjacent buildings but preserve natural systems or existing features, enable better solar exposure or site orientation, and/or make for interesting urban form

CS2 - D 05

Respect for Adjacent Sites: Respect adjacent properties with design and site planning to minimize disrupting the privacy and outdoor activities of residents in adjacent buildings.

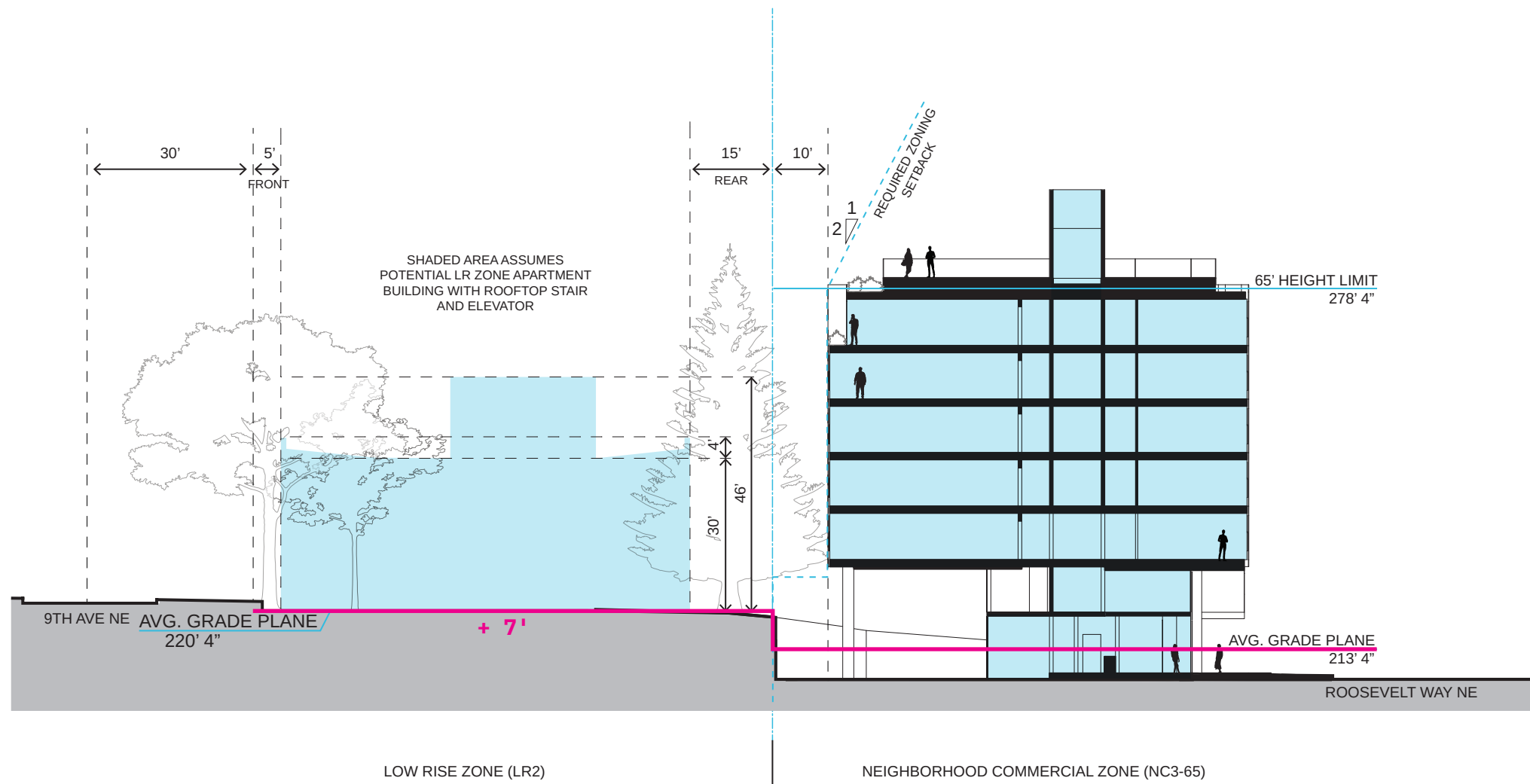

3. ZONE TRANSITION

DESIGN REVIEW BOARD DIRECTION:

a. The Board supported the 15' setback along the west property line shown in Options 1 and 2 with the building pushed closer to Roosevelt Ave. The Board supported the introduction of balconies on the west side of the building (shown in all three options) , noting that balconies provided an appropriate relationship with the adjacent single -family dwellings. However, the Board thought the introduction of balconies was not enough, noting the lack of modulation along the west façade. The Board requested the applicant further study ways to soften the western edge of the building and alleviate the 5-story façade. The Board suggested the applicant explore

DESIGN RESPONSE

+ In addition to the under improved aspect of the block, topography is a factor. The less intense LR2 zone is approximately 7'-0" higher in elevation that the NC3 zone. The section to the right shows the differences in average grade planes for the east and west sides of the block. This places development to the west of the site higher than the proposed site thereby somewhat mitigating the height differences between the NC3 and LR2 zone.

ZONING TRANSITION

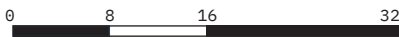

Vertical circulation on east facade and at the ends of the corridors on the north and south facades allows for more setback on the west facade



Vertical circulation and services centered in the floor plate rather than on the east facade to better active the street front, reduces the perceived height of the elevator penthouse from the street and allows for "notches" at the ends of the corridor on the north and south facades upper level recessed setbacks on L06 are proposed to signify a datum and height relationship to the LR2 zone to the west

3. ZONE TRANSITION

DESIGN REVIEW BOARD DIRECTION:

a. The Board supported the 15' setback along the west property line shown in Options 1 and 2 with the building pushed closer to Roosevelt Ave. The Board supported the introduction of balconies on the west side of the building (shown in all three options) , noting that balconies provided an appropriate relationship with the adjacent single -family dwellings. However, the Board thought the introduction of balconies was not enough, noting the lack of modulation along the west facade. The Board requested the applicant further study ways to soften the western edge of the building and alleviate the 5-story facade. The Board suggested the applicant explore deepening the balconies, creating more of a statement along this facade. **(DC2.C, University Supplemental Guidance CS2.2.b, DC2.2.i)**

Response:

+ The section on the left indicates a 7' +/- change in elevation of average grade plane between the east and west side of the block. This site feature somewhat mitigates the zone transition from the east, NC3 zone to the LR2 zone as the LR2 zone is higher than the structure proposed on the east side of the block in the NC3 zone. Additionally, EDG 2's design concept maximizes places for people to live, and reduces the building's footprint at the street level. EDG 2 removed units at grade along the west and the associated terraces. An open air, covered sports court below adds relief directly opposite from the existing neighbors to the west or a future apartment building. The rear yard setback is compliant with zoning. Vertical circulation and services centered in the building and away from the building facades and allows for more apartment frontage on the street. **(Please see pp 86 for additional information)**. The proposal exceeds the zoning setback at grade as well as at the recessed terraces on level 06 and introduces modulation on the upper level. The recessed terraces on level 06 is approximately at the roof line of the intended zoning height of the LR2 zone to the west. The recessed upper level balconies create a varied roof line subtly relating to the variety of roof lines created by the pitched roofs of the context to the west. **(Please see pp. 100 for additional information)**

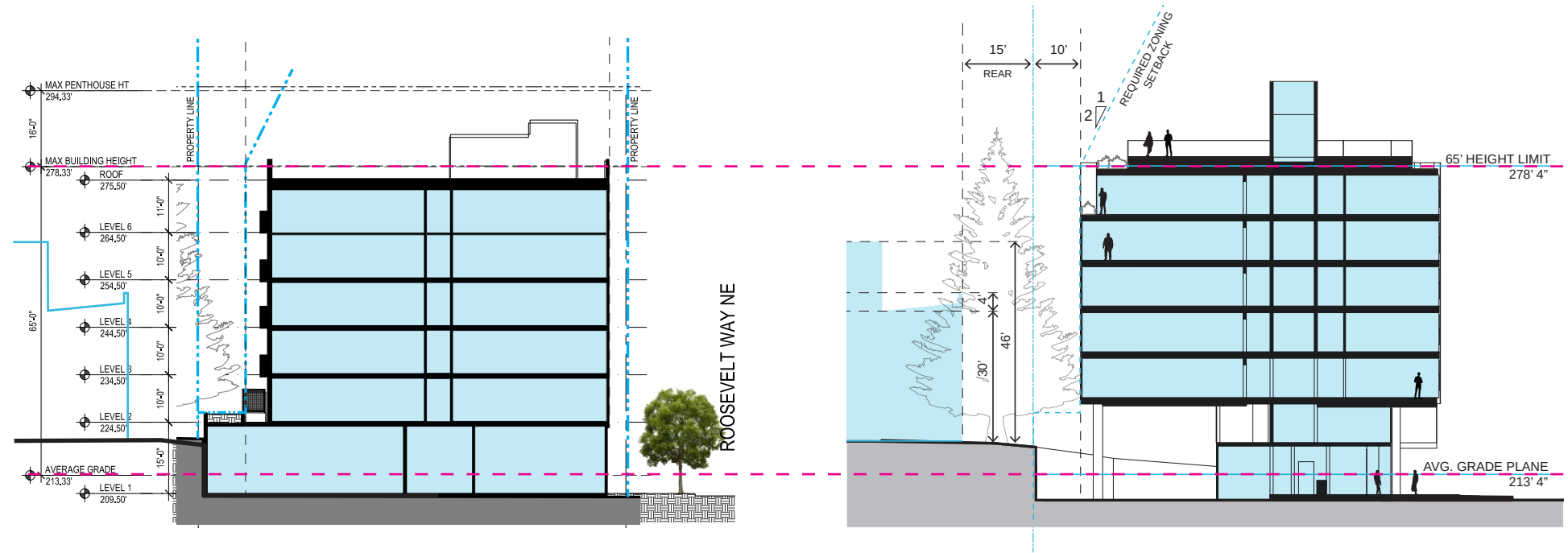

EDG 1



EDG 2

EDG 1 & EDG 2 BUILDING SECTION COMPARISON

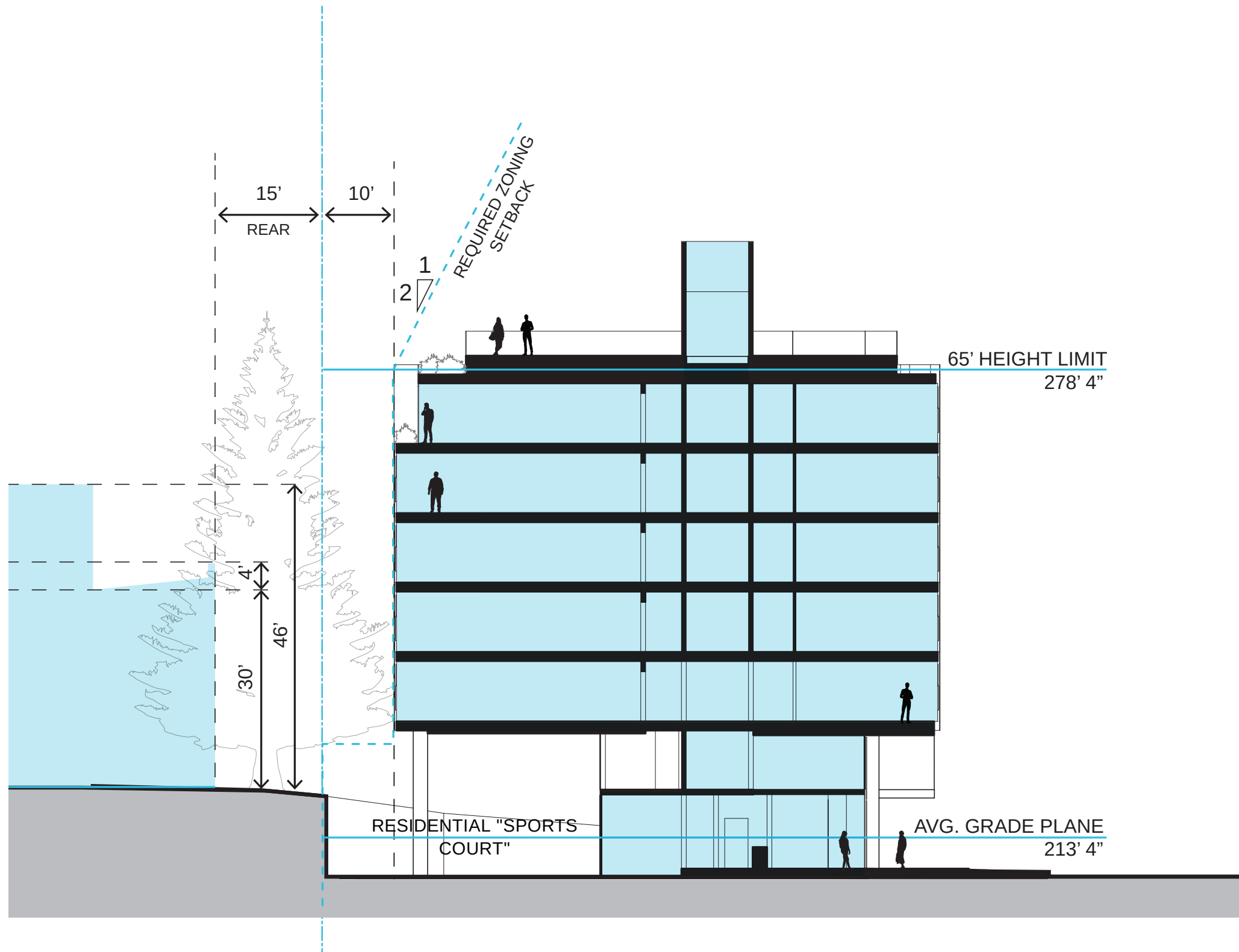

EDG 2 - BUILDING SECTION

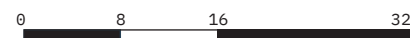

3. ZONE TRANSITION

a. The Board supported the 15' setback along the west property line shown in Options 1 and 2 with the building pushed closer to Roosevelt Ave. The Board supported the introduction of balconies on the west side of the building (shown in all three options) , noting that balconies provided an appropriate relationship with the adjacent single -family dwellings. However, the Board thought the introduction of balconies was not enough, noting the lack of modulation along the west facade. The Board requested the applicant further study ways to soften the western edge of the building and alleviate the 5-story facade. The Board suggested the applicant explore deepening the balconies, creating more of a statement along this facade. **(DC2.C, University Supplemental Guidance CS2.2.b, DC2.2.i)**

Response:

+ The section on the left indicates a 7' +/- change in elevation of average grade plane between the east and west side of the block. This site feature somewhat mitigates the zone transition from the east, NC3 zone to the LR2 zone as the LR2 zone is higher than the structure proposed on the east side of the block in the NC3 zone. Additionally, the proposal's design priority to maximize places for people to live, reduced the building's footprint at the street level. The proposal removed units at grade along the west and the associated terraces. An open air, covered "sports court" area below adds relief directly opposite from the existing neighbors to the west or a future apartment building. The rear yard setback is compliant with zoning. The proposed setback for EDG1, Alternative 3's was 14'- 6" with 18" deep projecting balconies. **(Please see pp 73 for additional information).**

EDG 2's The proposal exceeds the zoning setback at grade as well as at the recessed terraces on level 06 and introduces modulation on the upper level. No projecting balconies are proposed. **(Please see pp. 75 for additional information)**



Upper level setbacks at 30' intervals reflecting historic platting patterns;
setbacks as recessed terraces rather than projecting balconies to provide more
separation and privacy from west neighbors; porous base providing more separation
and relief from west neighbors

CS2.D.3 ZONE TRANSITION
CS2.D.4, MASSING CHOICES
CS2.D.5, RESPECT FOR ADJACENT SITES
DC2.D.1 VISUAL DEPTH AND INTEREST

EDG 2 - WEST FACADE CONCEPT | VIEW FROM WEST

13 | STREET LEVEL CONCEPT

4. GROUND PLANE / SITE PLANNING

DESIGN REVIEW BOARD DIRECTION:

a. The Board requested the applicant provide a calculation of the required amenity area for the Board members to better understand what the required minimum amenity area for the project is. In addition to this information, the Board requested the applicant provide opportunities to introduce a commercial space at the street level.

The Board was concerned the large amenity space at the street level would not activate the street and instead create a dead zone along the building's street frontage.

The Board requested the amenity space provide the flexibility to permit a future commercial space(s) to provide for street activation. The Board requested the applicant study the adaptability of the amenity space to convert to commercial spaces in the future. **(DC1.A.3, University Supplemental Guidance PL3.3.f, PL3.3.d, PL3.3.e)**

b. The Board expressed concern that the largest massing move along the street level was associated with the garage entrance. In addition, Board members had concerns that the primary pedestrian entrance was too close in proximity to the garage entrance. The Board recommended the pedestrian access become more unified and requested studies for different entrance locations to better separate the pedestrian entrance from the garage access. This change in the lobby location would coincide with changes to the interaction with the lobby and amenity space. **(University Supplemental Guidance PL3.1.a)**

c. The Board generally supported the direction of the site landscaping, suggesting the applicant work with the Seattle Department of Transportation to increase the landscaping within the right-of-way, along the street between the sidewalk and dedicated bike lane. The Board supported the direction and intent of the landscaping along the west side of the project site. **(DC4.D)**

d. The Board had concerns with the location of the bike parking access on the north side of the building, next to the garage entrance. The Board requested additional options for the bike parking access, suggesting it may be appropriate to group the bike parking access closer to or combined with the main entrance to the building. **(University Supplemental Guidance PL4.1)**

+ Response: Please see following page

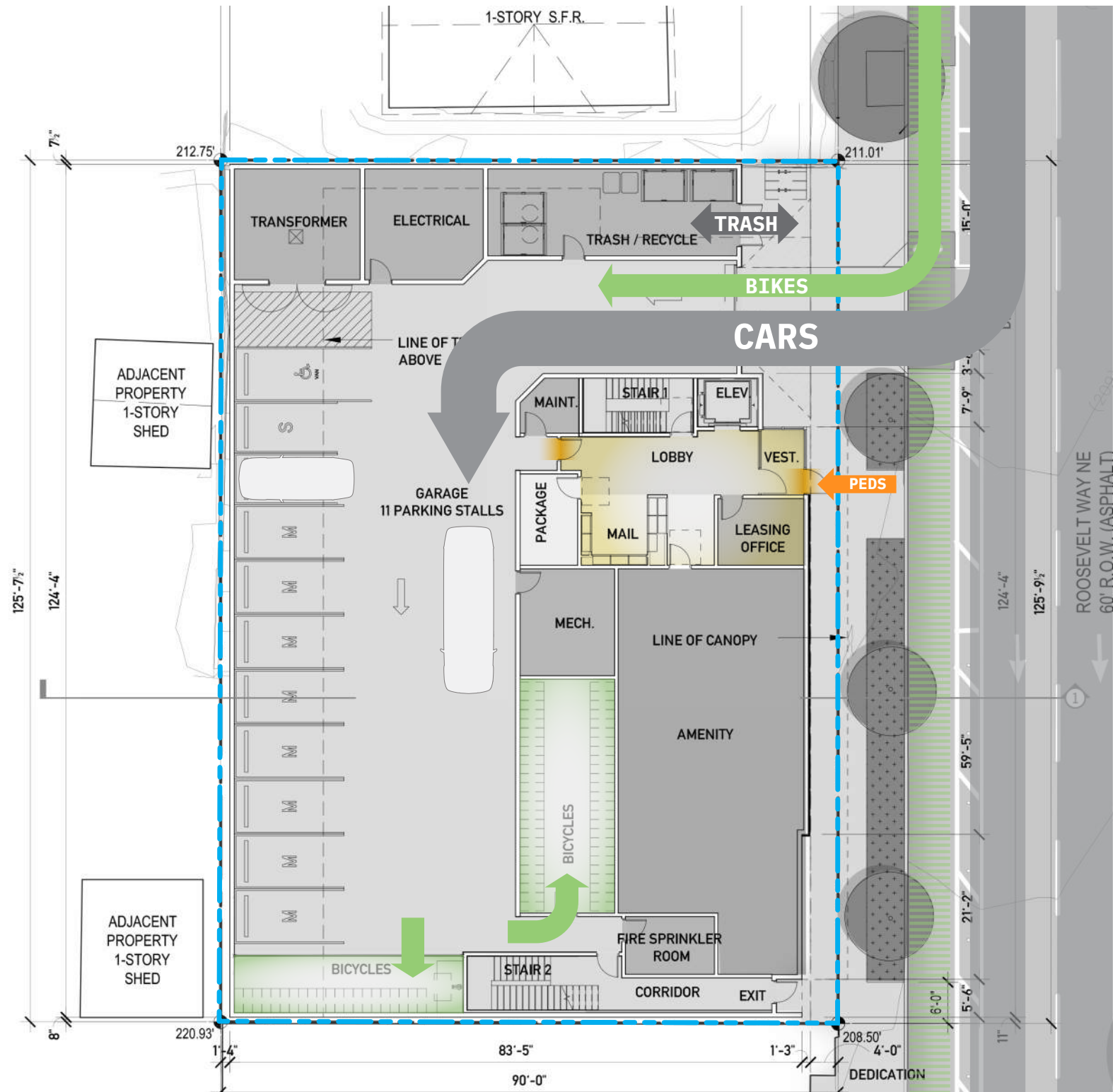

EDG 1 STREET LEVEL CONCEPT

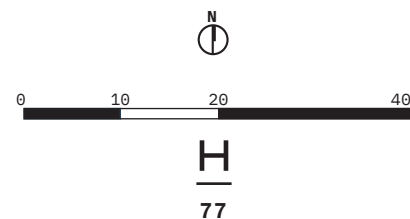

4. GROUND PLANE / SITE PLANNING (CONT.)

DESIGN REVIEW BOARD DIRECTION:

(Previous Page)

+ Response: The garage entrance was eliminated. There is no longer a vehicle garage proposed but a double height building entry on the south end of the street front. This access point proposes a 10' wide drive for occasional move-in / out needs. The access point on the south combines the main building entry. It also serves as a means for people and bikes to enter the site. This leads to an open-air "sports court" for residents. Vehicle move-in / out will also happen in this location. The entrance for residents, bikes and move-in / out access has been separated from the access point to the trash and recycling room which remains on the north end of the street front in a similar fashion as the EDG 1 concept.

++ Response: To Additionally to better activate the street level facade the EDG 2 alternative's street level concept:

- Sets the facade 7'-8" +/- further back from the property line to add more planting area and overhead weather protection by the structure above.
- "Inflected" the center bays to add variety and a smaller scale to the street front.
- Relocates all required amenity area per zoning to the rooftop terrace, allowing for the ability to convert a portion of the street level to a retail kiosk in the future
- The north "inflected bay" is proposed as a residential amenity space but could be converted into a retail kiosk. [Please see pp. 80-81 for retail kiosk concept.](#)
- Eliminated the parking Substantially reduced the amount of enclosed building area to make a more porous street level offering views into the residential "sport court" and beyond.
- Provides residents multiple points on exit / entry along the street front
- Provides on-site move-in / out and delivery needs.



EDG 2 STREET LEVEL CONCEPT

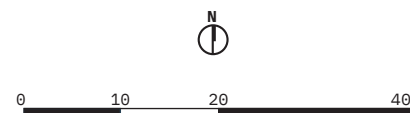

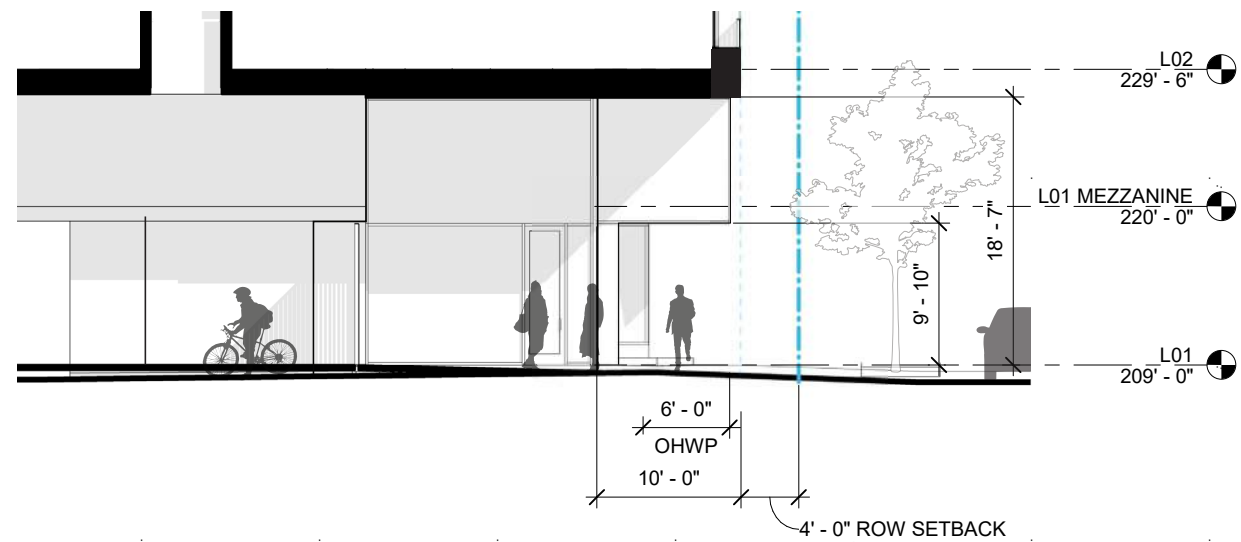

SECTION A

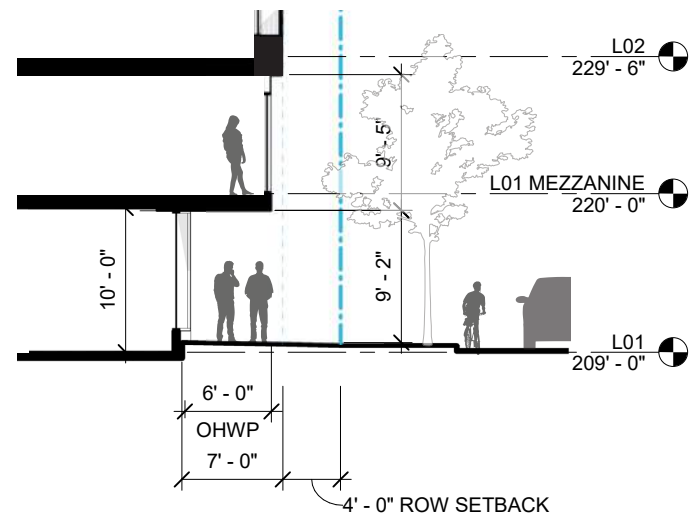

SECTION B

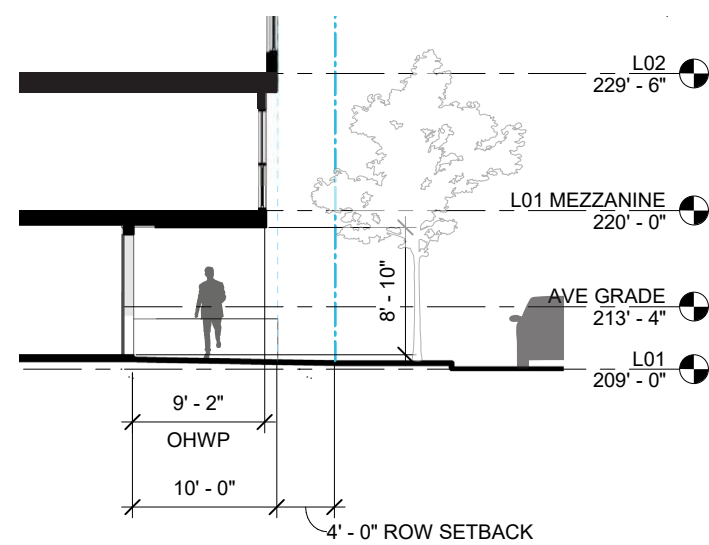

SECTION C

4. GROUND PLANE / SITE PLANNING (CONT.)

DESIGN REVIEW BOARD DIRECTION:

(Please see previous pages)

+++ Response: For additional reference, to the left are street sections showing the additional setback proposed and overhead weather protection provided by the level above extending to the 4'-0" street ROW setback.

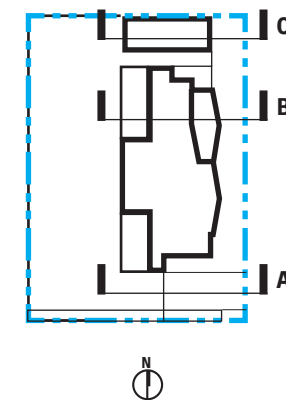

ENLARGED STREET SECTIONS

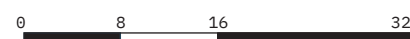

4. GROUND PLANE / SITE PLANNING

DESIGN REVIEW BOARD DIRECTION:

a. . . The Board requested the applicant provide opportunities to introduce a commercial space at the street level.

The Board was concerned the large amenity space at the street level would not activate the street and instead create a dead zone along the building's street frontage.

The Board requested the amenity space provide the flexibility to permit a future commercial space(s) to provide for street activation. The Board requested the applicant study the adaptability of the amenity space to convert to commercial spaces in the future. (DC1.A.3, University Supplemental Guidance PL3.3.f, PL3.3.d, PL3.3.e)

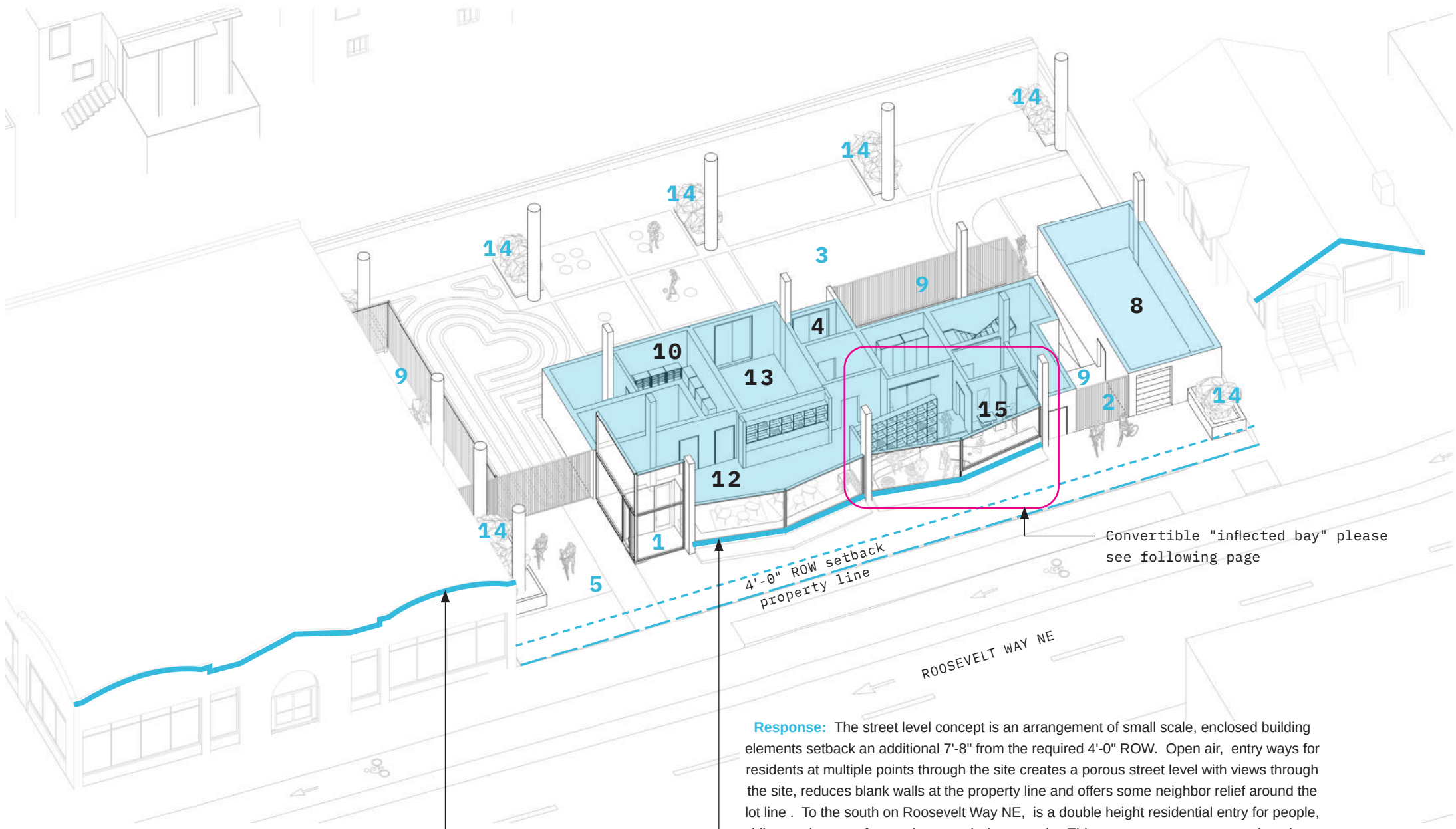

- 1. RESIDENTIAL ENTRY
- 2. RESIDENTIAL "BACK DOOR" ENTRY
- 3. RESIDENT RECREATION / SPORT'S COURT
- 4. RESIDENTIAL "BACK DOOR" / MOVE-IN/OUT
- 5. DOUBLE HEIGHT ENTRY / ACCESS
- 6. RESIDENTIAL LOUNGE
- 7. NOT USED
- 8. ENCLOSED TRASH AND RECYCLING ROOM
- 9. SECURE BUT UNENCLOSED RESIDENTIAL BICYCLE PARKING
- 10. MAIL
- 11. NOT USED
- 12. RESIDENTIAL LOBBY AND LEASING
- 13. TRANSFORMER VAULT
- 14. PLANTER
- 15. RESIDENTIAL STUDY
(POTENTIAL TO BE CONVERTED TO A RETAIL KIOSK)

Response: The street level concept is an arrangement of small scale, enclosed building elements setback an additional 7'-8" from the required 4'-0" ROW. Open air, entry ways for residents at multiple points through the site creates a porous street level with views through the site, reduces blank walls at the property line and offers some neighbor relief around the lot line. To the south on Roosevelt Way NE, is a double height residential entry for people, bikes and access for on-site move-in / out needs. This space opens to a covered outdoor recreation area for residents. Two "inflected" bays modulate the street-scape and subtly reflect the parapets and rooftops of its neighbors. The bay to the south encloses residential leasing functions, while the adjacent bay to the north is intended to be a residential study that could be converted into an retail kiosk or pop-up style retail.

Proposed "Inflected bays" reflecting qualities of the existing parapets and roof forms of its neighbors

STREET LEVEL CUT-AWAY ISOMETRIC

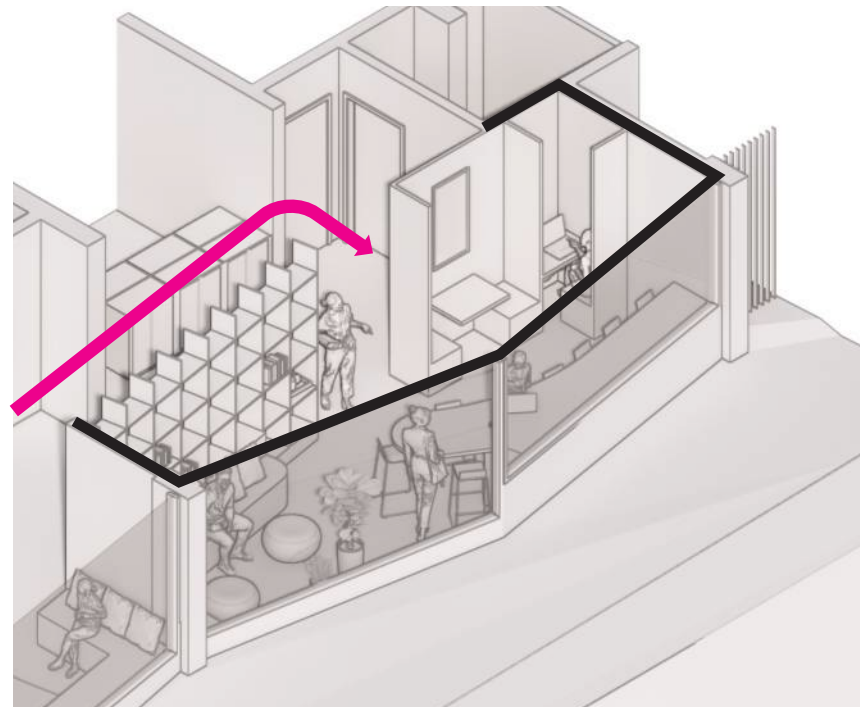

1. RESIDENT STUDY (base option)

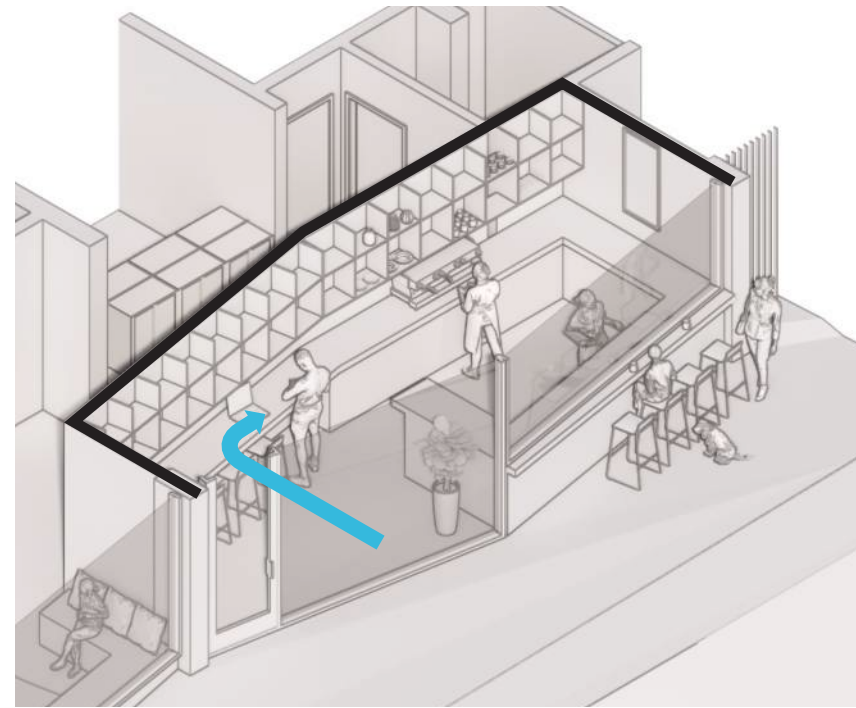

2. RETAIL KIOSK CONVERSION

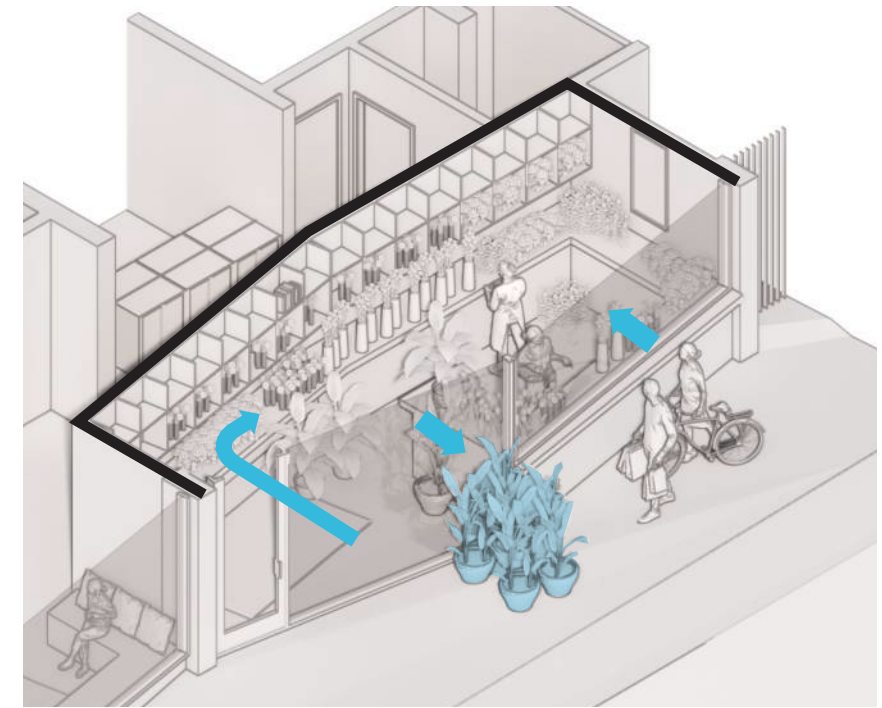

3. POP-UP STYLE RETAIL CONVERSION

The northern bay with an "inflected" street facade is proposed as a residential co-working or study area. It is not part of the required zoning amenity area and therefore could be converted into a number of retail uses accessed from the street.

UDSG - PL3-3-f DESIGN FOR COMMERCIAL USE CONVERSION

STREET LEVEL CONVERTIBLE USES

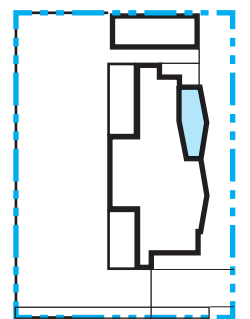

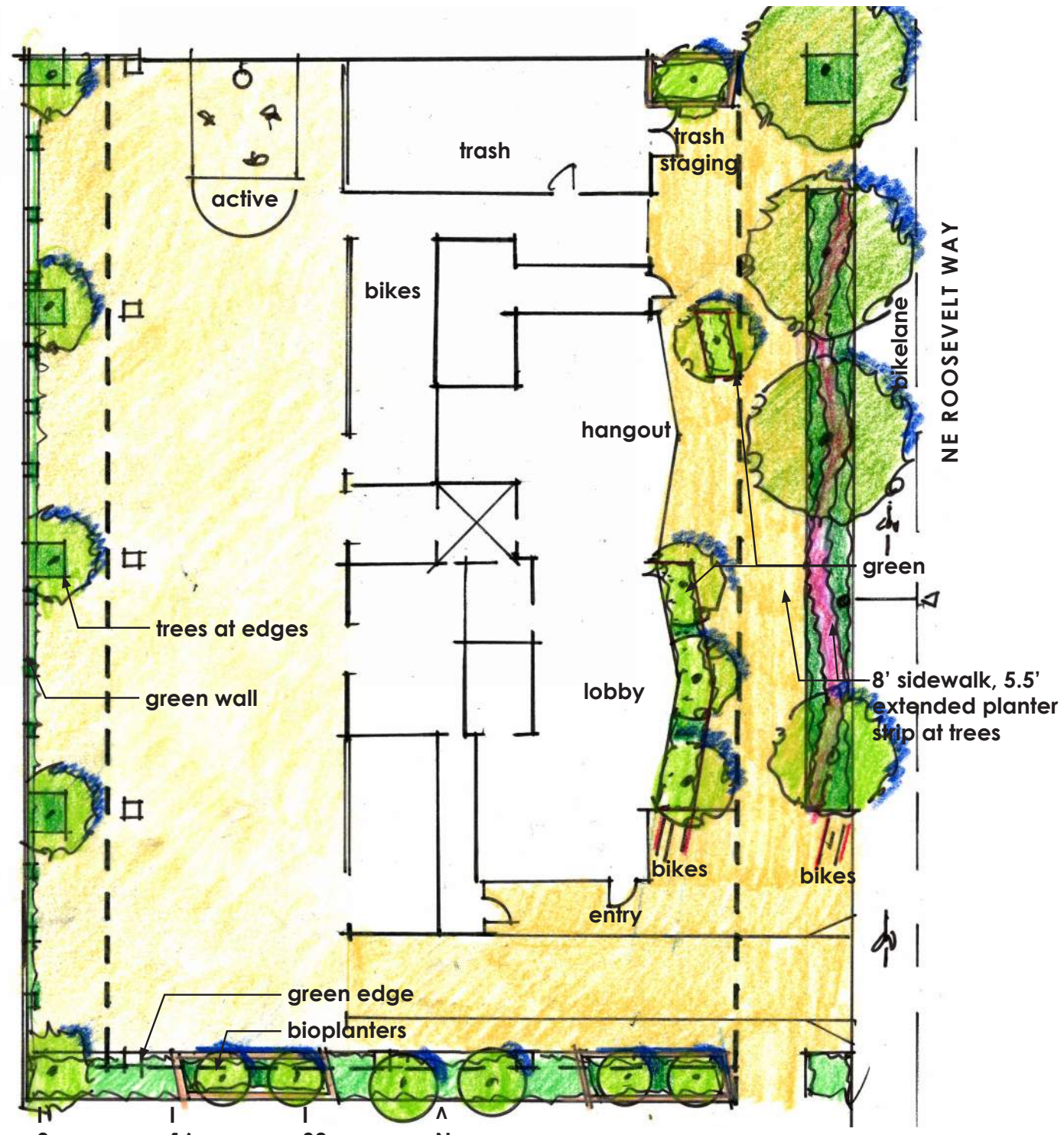

LANDSCAPE CONCEPTUAL SKETCH - STREET LEVEL



14 | FLOOR PLANS

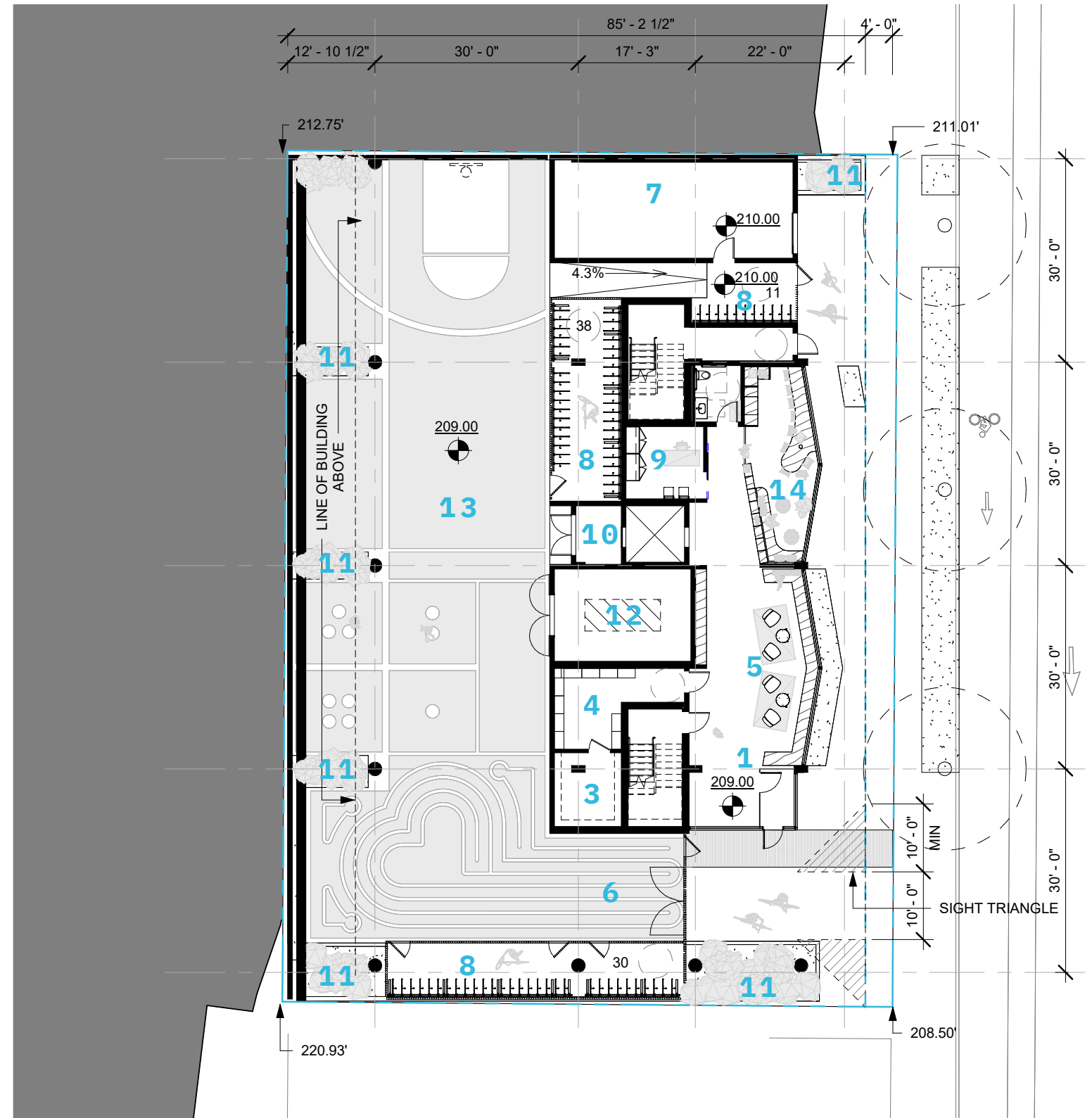

ROOSEVELT WAY NE

- 1. RESIDENTIAL ENTRY
- 2. NOT USED
- 3. PARCEL
- 4. MAIL ROOM
- 5. RESIDENTIAL LOBBY
- 6. PEOPLE / BIKES / ACCESS FOR ON SITE MOVE IN/OUT
- 7. TRASH AND RECYCLING
- 8. SECURE RESIDENTIAL BICYCLE PARKING
- 9. LEASING OFFICE
- 10. MOVE IN / MOVE OUT & RESIDENTIAL "BACK DOOR"
- 11. PLANTER
- 12. TRANSFORMER VAULT
- 13. RESIDENTIAL OUTDOOR RECREATION AREA "SPORT COURT"
- 14. RESIDENTIAL CO-WORK LOUNGE (CONVERTIBLE TO A RETAIL KIOSK)

EDG 2 - L01 - STREET LEVEL PLAN

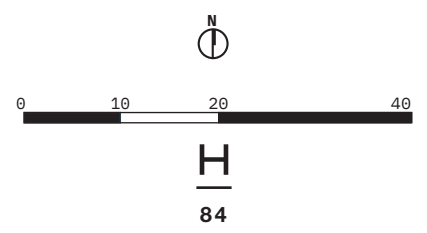

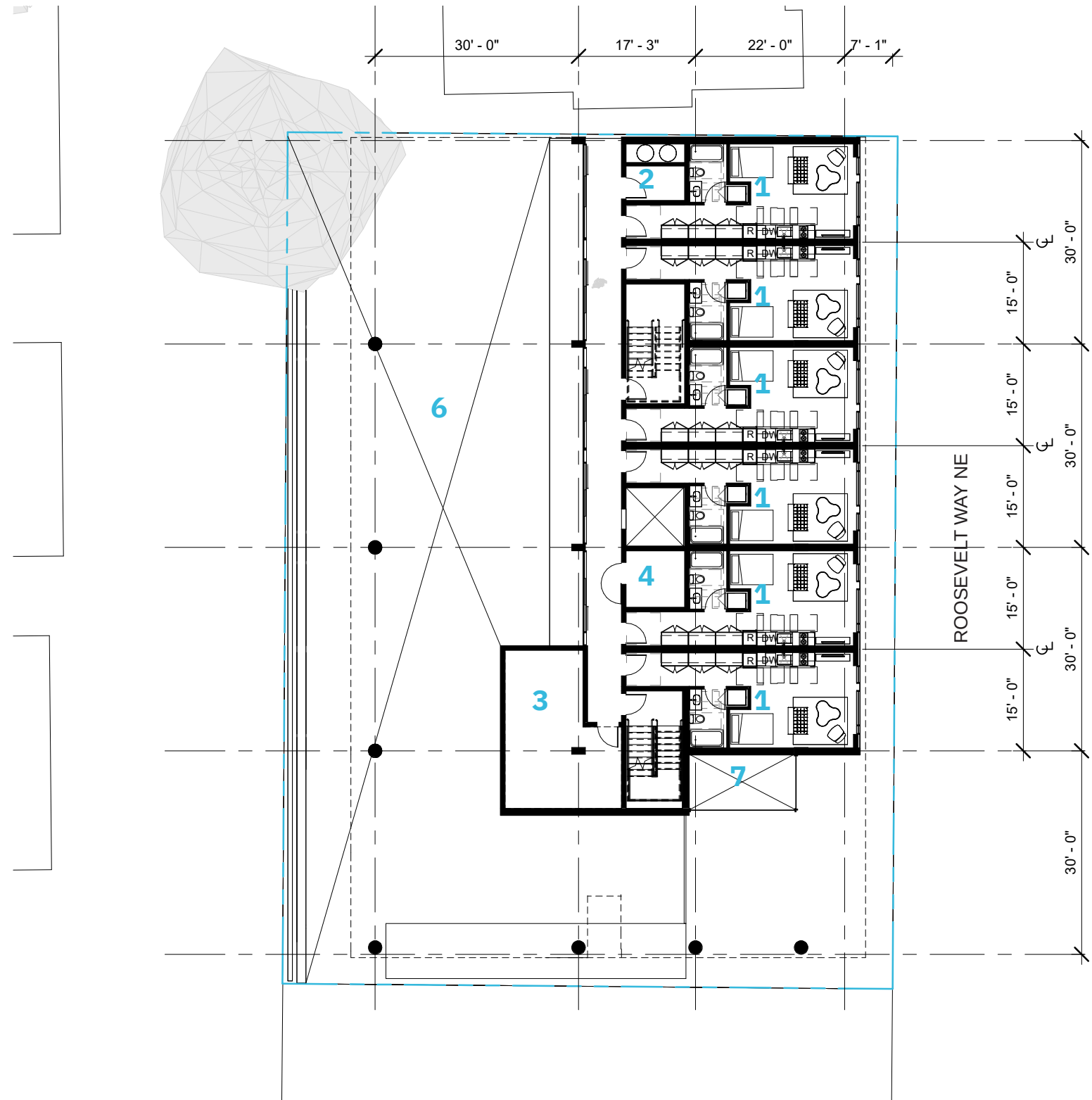

- 1. STUDIO UNIT
- 2. TRASH // RECYCLING RM
- 3. MAIN ELECTRICAL RM
- 4. ELEC // TELECOM
- 5. OUTDOOR SCREENED MECH
- 6. RESIDENTIAL RECREATION BELOW "SPORT COURT"
- 7. RESIDENTIAL LOBBY BELOW

EDG 2 - L01 - MEZZANINE PLAN

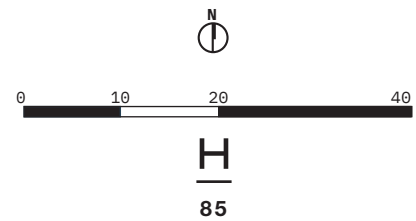

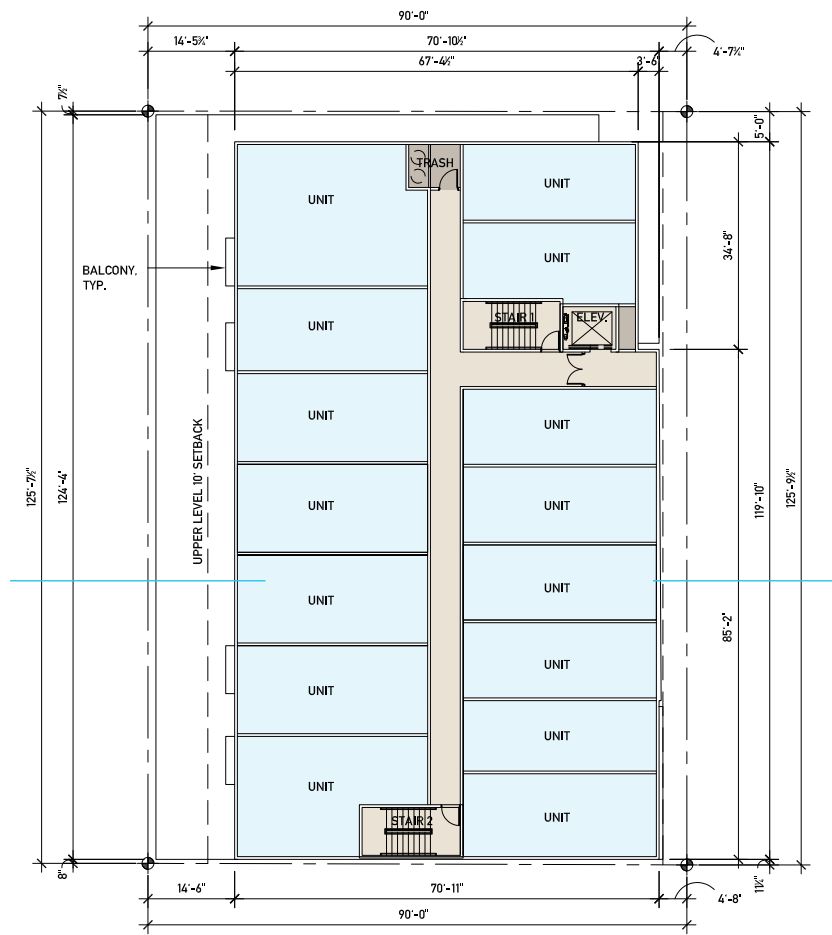

EDG 1 - ALT 3

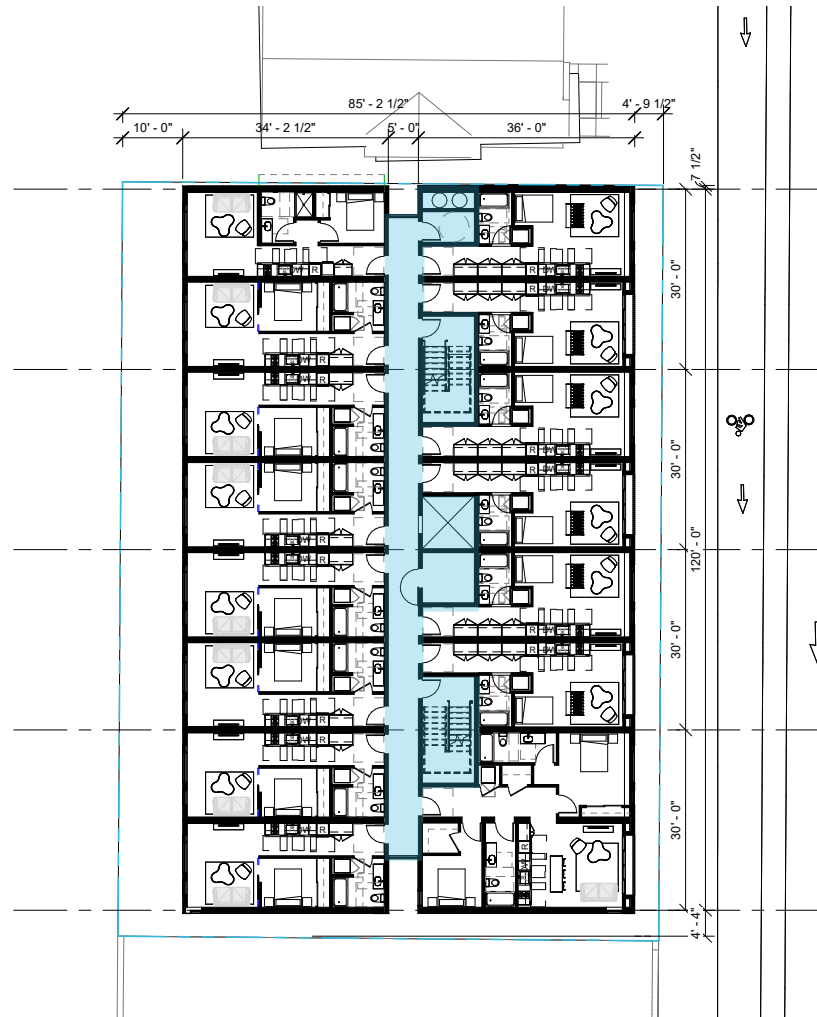

EDG 2

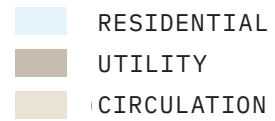

EDG 1 & EDG 2 TYPICAL RESIDENTIAL FLOOR COMPARISON



2. MASSING

c. The Board stated that they struggled with all three options and expressed to the applicant that there was not enough exploration done at this stage to move forward with a recommendation from the Board. Out of the three options, the Board identified some support for Option 2 due its overall form, vertical break, balconies on the west façade, and location of the interior uses. The Board requested the applicant further study massing options for the building. This includes studying whether flipping the location of the stairway and elevator will lead to less of a blank wall effect along Roosevelt Avenue. The Board also requested the applicant study how to integrate massing breaks at the 20' to 40' intervals recommended by the University Supplemental Design Guidelines and demonstrate how the interior uses of the building inform the massing design. The Board also requested two dimensional elevations of the updated massing design and east/west and north/south sections of the proposed building in relation to existing buildings. **(DC2.A.1, DC2.B.2, DC2.E, University Supplemental Guidance – CS2.1.e)**

+ Response: The internal plan arrangement has been revised to place the vertical circulation and services to the center of the floor plates to allow for more living area on the street facade and "notches" on the north and south facades. The building has been shifted to the north to allow for limited glazing on the south facade as it is considered by the board to be more visible and likely to remain that way longer than the north elevation.

15 | ROOF LEVEL

4. GROUND PLANE / SITE PLANNING

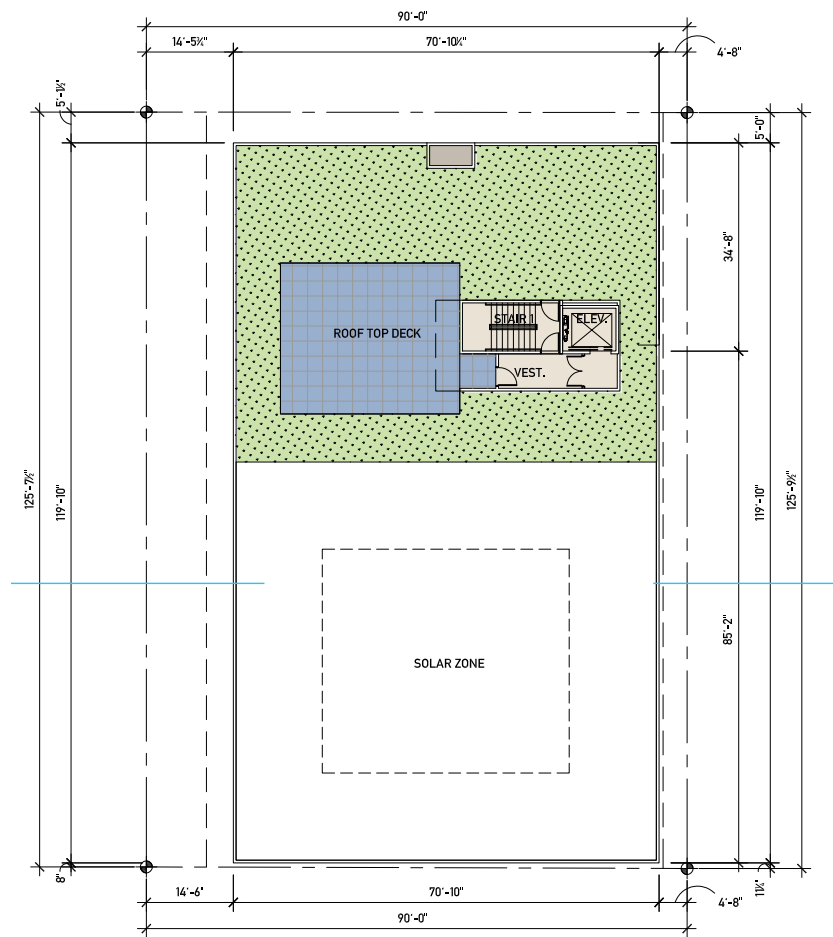

EDG 1 - ALT 3 ROOF PLAN

- CIRCULATION
- PLANTING STRIP / LANDSCAPE
- RESIDENTIAL AMENITY

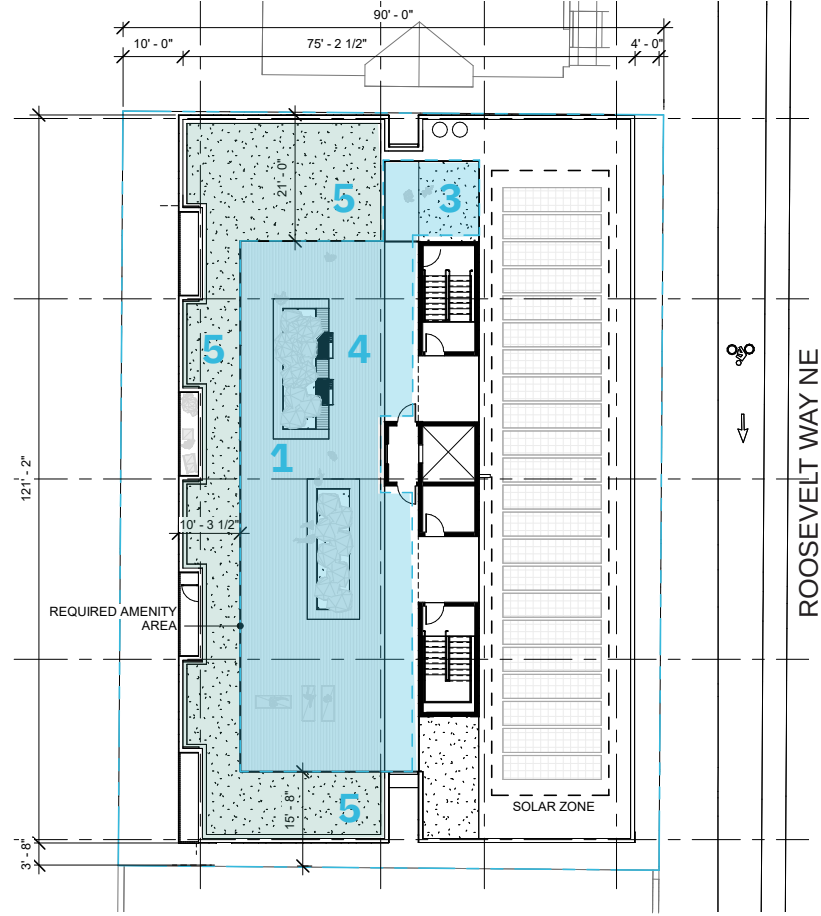

EDG 2 - ROOF PLAN

- 1. OUTDOOR AMENITY (+/- 2,550 SF REQUIRED)
- 2. MECH
- 3. 200 SF MAX PET AREA
- 4. GRILL STATIONS
- 5. PLANTING BUFFER ALONG ROOF EDGES

EDG 1 & EDG 2 - ROOF PLAN COMPARISON

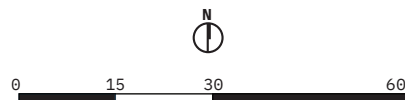

a. The Board requested the applicant provide a calculation of the required amenity area for the Board members to better understand what the required minimum amenity area for the project is. In addition to this information, the Board requested the applicant provide opportunities to introduce a commercial space at the street level. The Board was concerned the large amenity space at the street level would not activate the street and instead create a dead zone along the building's street frontage. The Board requested the amenity space provide the flexibility to permit a future commercial space(s) to provide for street activation. The Board requested the applicant study the adaptability of the amenity space to convert to commercial spaces in the future. **(DC1.A.3, University Supplemental Guidance PL3.3.f, PL3.3.d, PL3.3.e)**

Response: The amenity area required by zoning is proposed to be outdoors per SMC. 23.47A.024.B.2 "Amenity areas shall not be enclosed." The unenclosed amenity area is located on the rooftop terrace. By removing the amenity area from the street level, the ability to consider future retail uses is proposed. **(Please see the flowing page for residential amenity area calculations and SDCI Gross Floor Area diagrams & pp 78-81 for street level information.)**

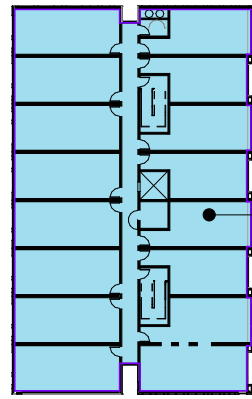

Area
8610 SF

L02

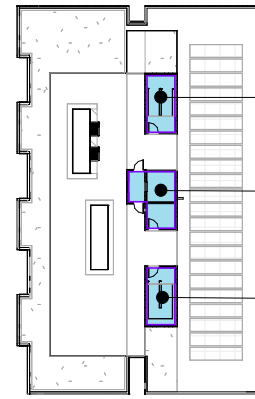

Area
153 SF
Area
206 SF
Area
153 SF

MAX ZONING HT

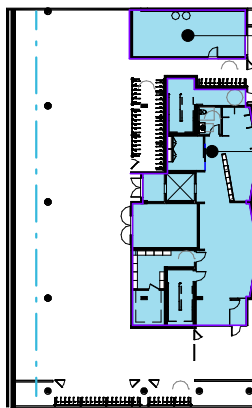

Area
548 SF
Area
2454 SF

L01

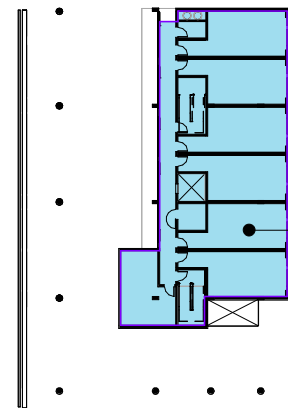

GFA
3925 SF

L01 MEZZANINE

EDG 2	SDCI GFA
ROOF	512
L06	8,390
L05	8,715
L04	8,610
L03	8,715
L02	8,610
L01 MEZZANINE	3,925
L01	3,002
TOTALS	50,479
5% AMENITY AREA	2,524

4. GROUND PLANE / SITE PLANNING

a. The Board requested the applicant provide a calculation of the required amenity area for the Board members to better understand what the required minimum amenity area for the project is. In addition to this information, the Board requested the applicant provide opportunities to introduce a commercial space at the street level.

The Board was concerned the large amenity space at the street level would not activate the street and instead create a dead zone along the building's street frontage.

The Board requested the amenity space provide the flexibility to permit a future commercial space(s) to provide for street activation. The Board requested the applicant study the adaptability of the amenity space to convert to commercial spaces in the future. (DC1.A.3, University Supplemental Guidance PL3.3.f, PL3.3.d, PL3.3.e)

Response: Amenity area calculations and area diagrams provided. All required amenity area to be outdoors per SMC 23.47A.024

Note: Per zoning and for the purposes of calculating amenity area, gross floor area for mechanical purposes and accessory parking are excluded. Area calculation are preliminary and based solely as a function of the amount of gross floor area provided. Final amounts subject to change through the Master Use permitting process.

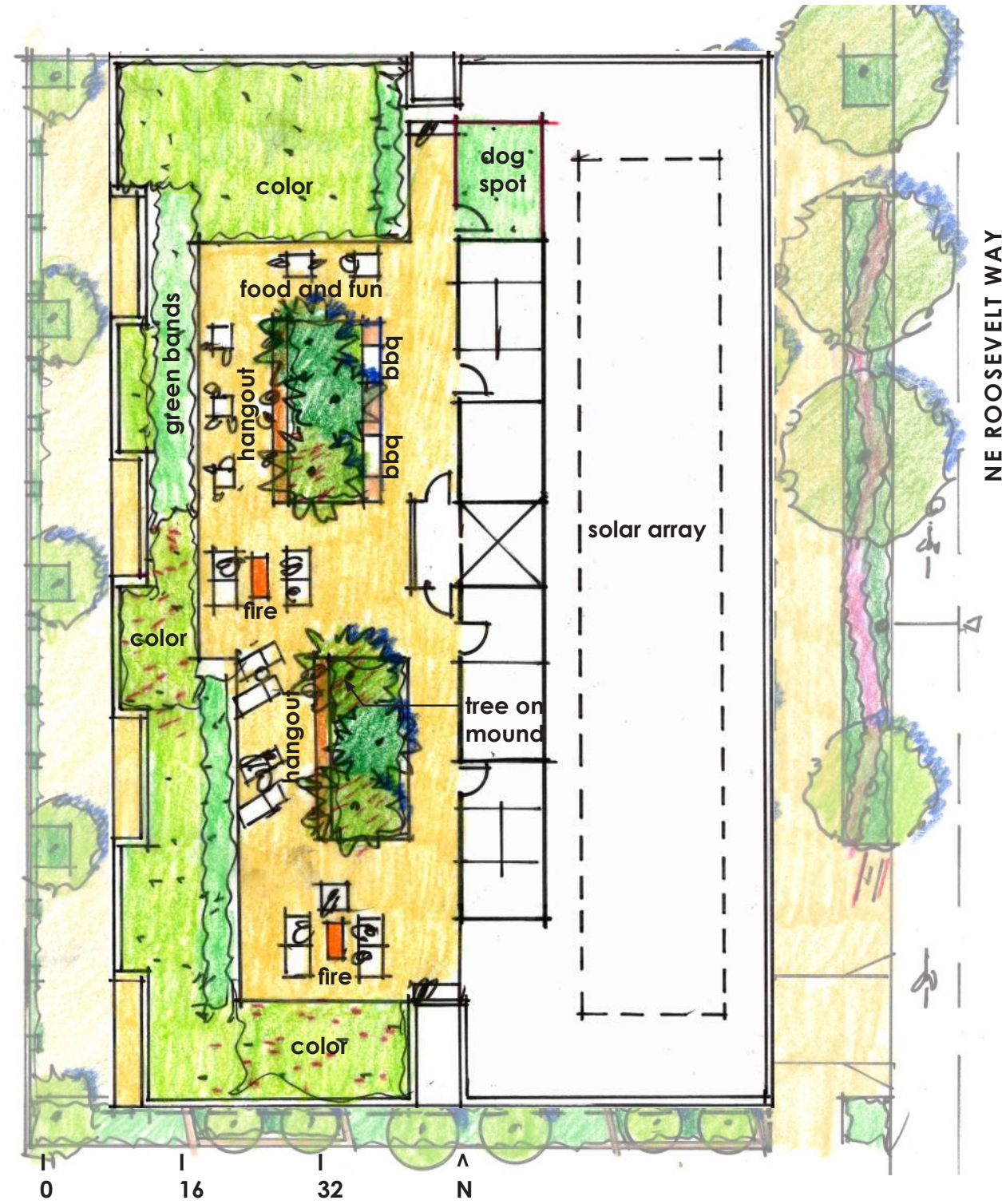

EDG 2 - LANDSCAPE CONCEPTUAL SKETCH - ROOF



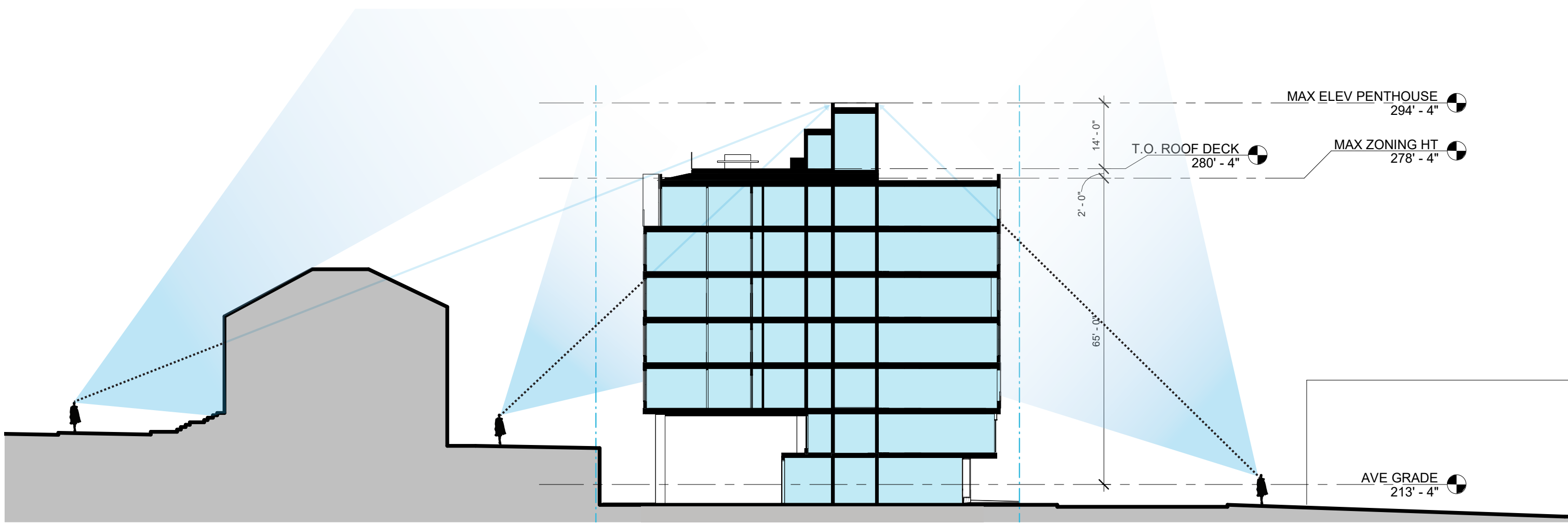

Vertical circulation and services centered in floor plate moves penthouse massing away from building edges reducing perceived bulk and height; roof terrace setback from edges moving activity further away from neighboring sites

- CS2.D.3 ZONE TRANSITION
- CS2.D.4, MASSING CHOICES
- CS2.D.5, RESPECT FOR ADJACENT SITES
- DC2.D.1 VISUAL DEPTH AND INTEREST

EDG 2 - ROOF AMENITY IS OFFSET FROM BUILDING EDGE TO LIMIT VISIBILITY

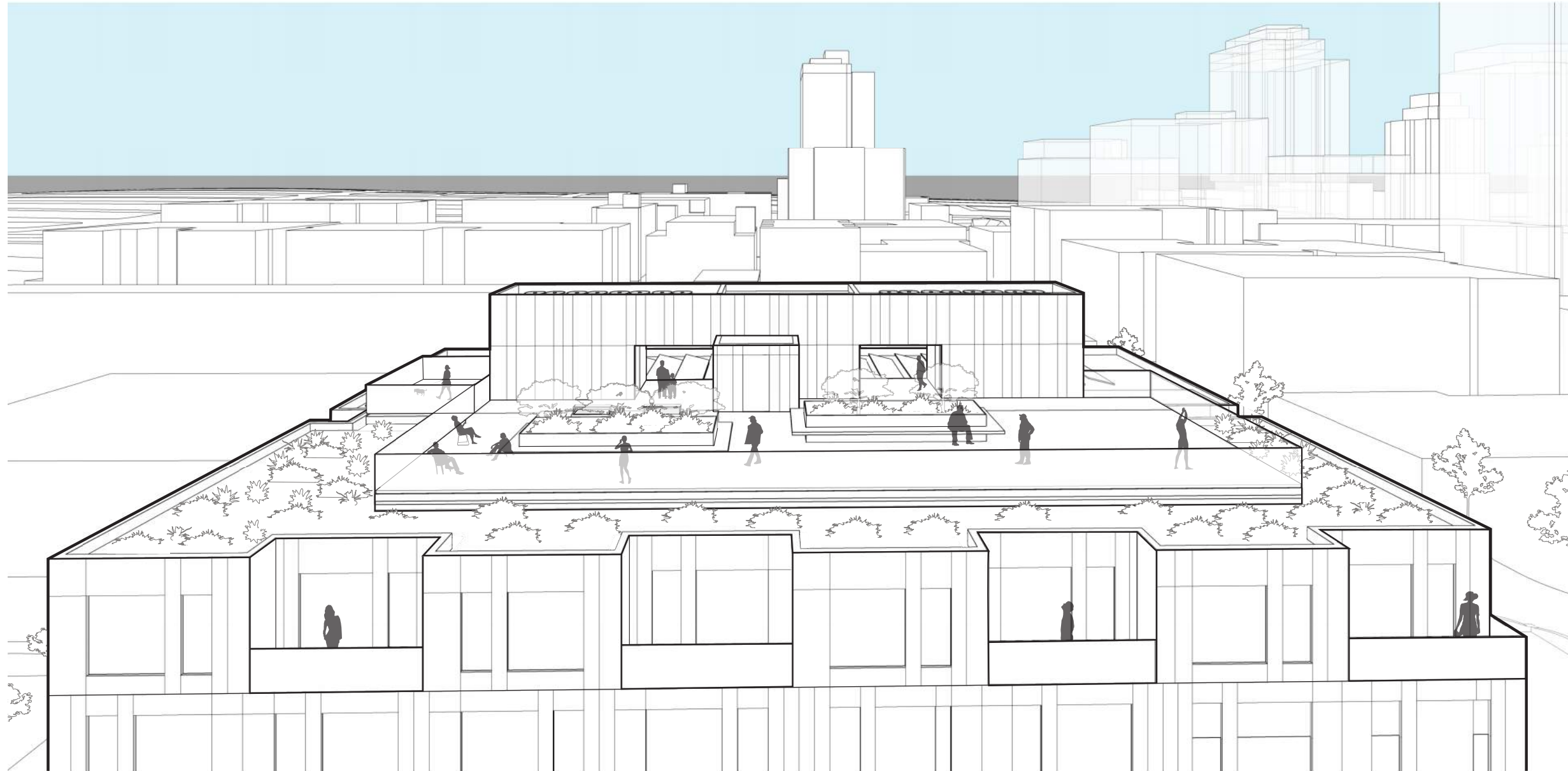

Vertical circulation and services centered in floor plate moves penthouse massing away from building edges reducing perceived bulk and height; roof terrace setback from edges moving activity further away from neighboring sites

CS2.D.3 ZONE TRANSITION
CS2.D.4, MASSING CHOICES
CS2.D.5, RESPECT FOR ADJACENT SITES
DC2.D.1 VISUAL DEPTH AND INTEREST

EDG 2 - ROOF LEVEL VIEW LOOKING EAST

16 | OVERALL EDG 2 VIEWS



Site context and analysis informing the east facade; Recessed Juliette balconies at 30' intervals reflecting historic platting patterns; large prominent entry adding deference to the existing commercial building to the south; smaller scale street level; increased setbacks from the ROW; porous openings through the site

CS2.B.1 SITE CHARACTERISTICS

CS2.C.2 MID-BLOCK SITES

UDSG - CS2.1.e.1 REFLECT HISTORIC PLATTING PATTERNS

UDSG - PL3.1.a PROMINENT ENTRIES

UDSG - DC2.2.a EMBRACE CONTEMPORARY DESIGN

STREET LEVEL VIEW AT ROOSEVELT WAY NE LOOKING NW



Trash and recycling access separated from main entry to the south; a secondary entry for people and bikes located between the north inflected bay; planting buffering the service entry door.

CS2.B.1 SITE CHARACTERISTICS

CS2.C.2 MID-BLOCK SITES

UDSG - CS2.1.e.1 REFLECT HISTORIC PLATTING PATTERNS

UDSG - PL3.1.a PROMINENT ENTRIES

UDSG - DC2.2.a EMBRACE CONTEMPORARY DESIGN

STREET LEVEL VIEW AT ROOSEVELT WAY NE LOOKING SW



Site context and analysis informing the east facade; Recessed Juliette balconies at 30' intervals reflecting historic platting patterns; larger prominent entry adding deference to the existing commercial building to the south; smaller scale street level; increased setbacks from the ROW; porous openings through the site

CS2.B.1 SITE CHARACTERISTICS

CS2.C.2 MID-BLOCK SITES

UDSG - CS2.1.e.1 REFLECT HISTORIC PLATTING PATTERNS

UDSG - PL3.1.a PROMINENT ENTRIES

UDSG - DC2.2.a EMBRACE CONTEMPORARY DESIGN

EAST FACADE CONCEPT | VIEW FROM ROOSEVELT WAY NE

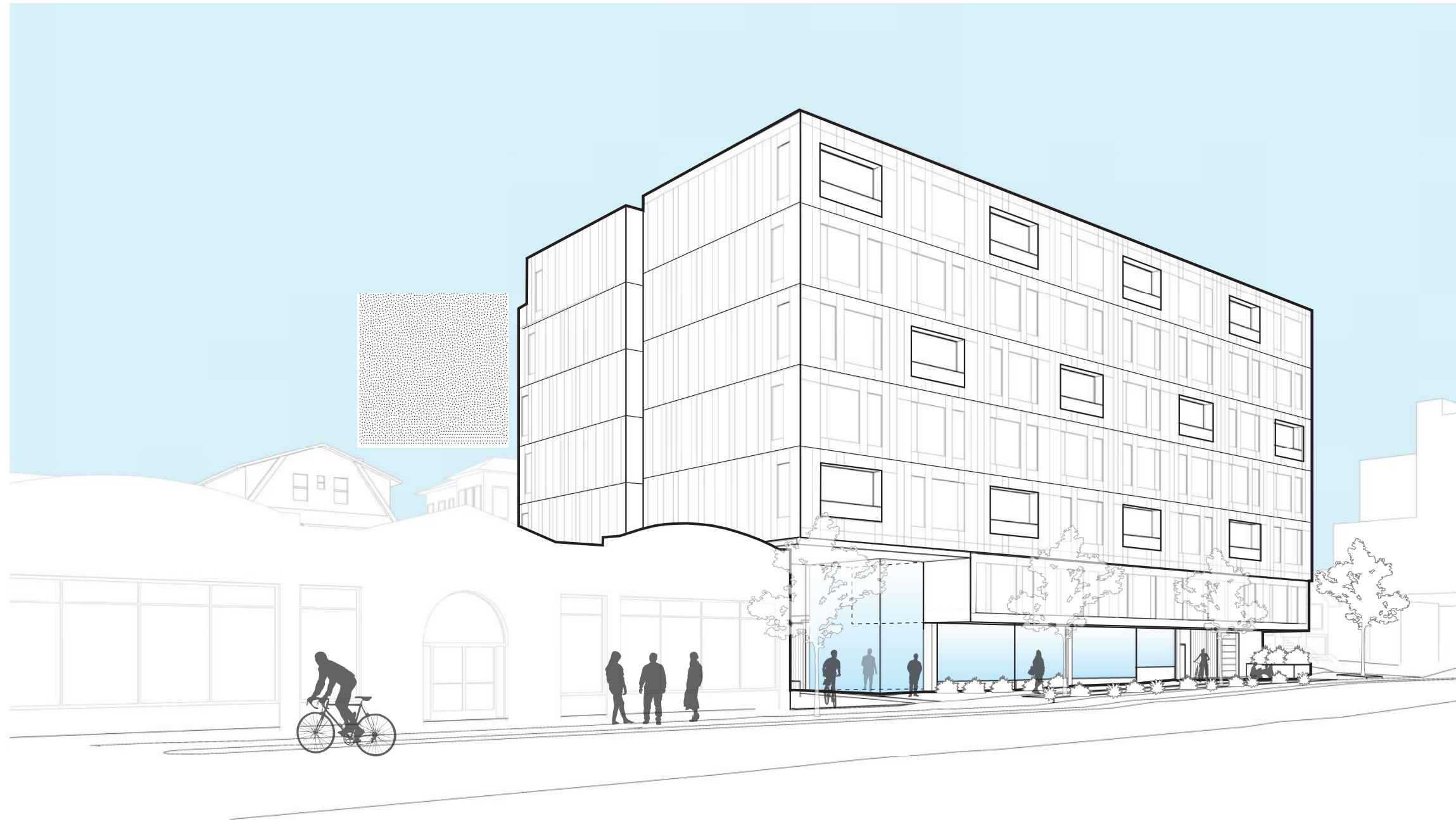

Entry relocated to the south; Double-height opening provides deference to the south commercial neighbor and a visible, prominent entry for the building; Single-story bar of units step down from the entry creating a datum reflecting the existing neighbors on the street

CS2.B.1 SITE CHARACTERISTICS

CS2.C.2 MID-BLOCK SITES

UDSG - CS2.1.e.1 REFLECT HISTORIC PLATTING PATTERNS

UDSG - PL3.1.a PROMINENT ENTRIES

UDSG - DC2.2.a EMBRACE CONTEMPORARY DESIGN

STREET LEVEL VIEW AT ROOSEVELT WAY NE LOOKING SW



Upper level setbacks at 30' intervals reflecting historic platting patterns;
setbacks as recessed terraces rather than projecting balconies to provide more
separation and privacy from west neighbors; porous base providing more separation
and relief from west neighbors

CS2.D.3 ZONE TRANSITION
CS2.D.4, MASSING CHOICES
CS2.D.5, RESPECT FOR ADJACENT SITES
DC2.D.1 VISUAL DEPTH AND INTEREST

WEST FACADE CONCEPT | VIEW FROM WEST



Proposed serrated roof edge reflecting the varied roof lines of west neighbors; recessed terraces at 30' intervals reflecting the platting patterns of the neighborhood and relative widths of smaller scale multi-family structures to the west; Residential roof terrace setback from roof edges

- DC2.C.3 FIT WITH NEIGHBORING BUILDINGS**
- UDSG - CS2.1.e.1 REFLECT HISTORIC PLATTING PATTERNS**
- UDSG - DC2.2.a EMBRACE CONTEMPORARY DESIGN**
- CS2.D.4, MASSING CHOICES**
- CS2.D.5, RESPECT FOR ADJACENT SITES**
- DC2.D.1 VISUAL DEPTH AND INTEREST**

WEST FACADE FROM 9TH AVENUE NE

17 | SUMMARY

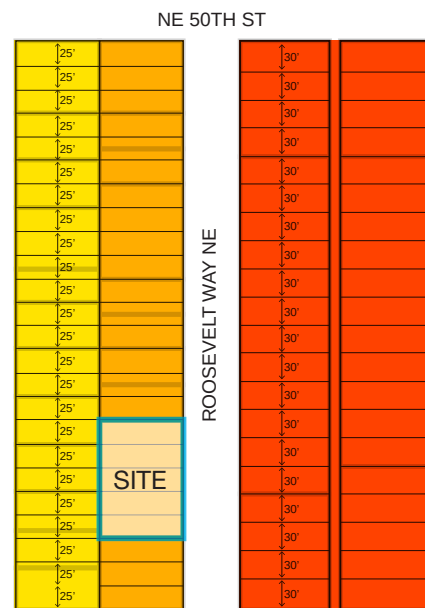

1

Inspiration from specific urban context in the neighborhood

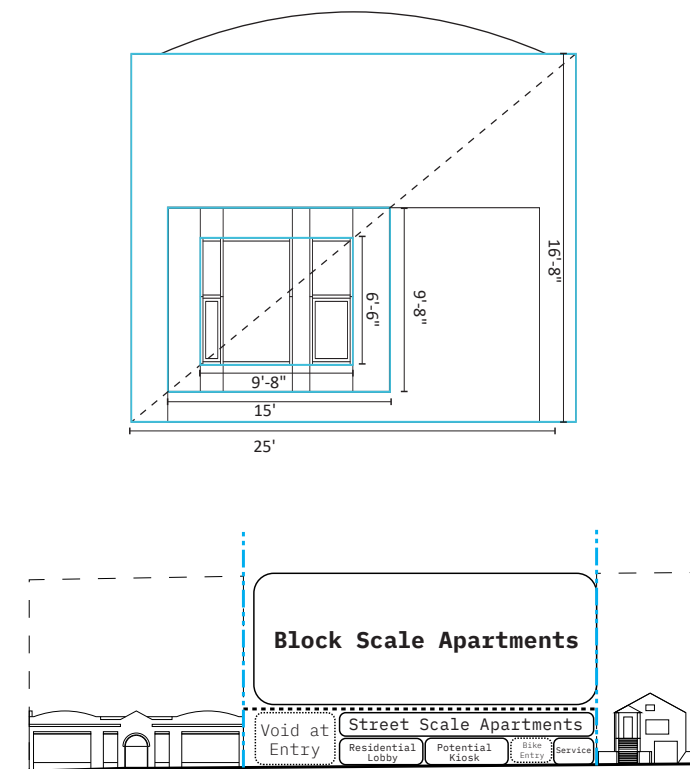

2

Considers localized context to inform massing and a street edge strategy

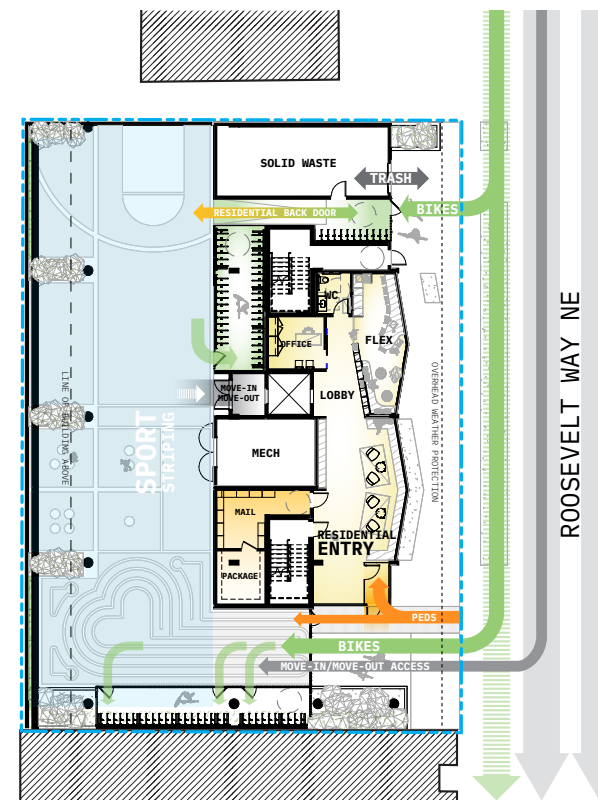

3

Considers ways to create an active street edge with variety and adaptability

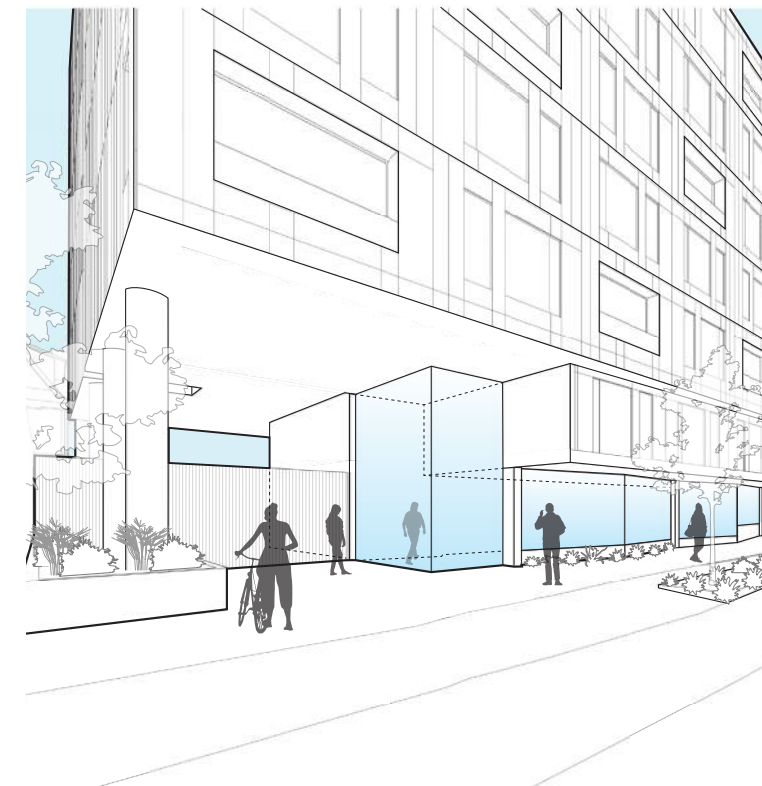

4

Relates to a smaller urban grain found in the neighborhood while providing places for people to live.

The proposed alternative responses to the board's direction because:

The EDG 2 concept is rooted in the neighborhood's original framework. It takes its design cues from its context and reflects them in a cohesive expression. The street scape is pedestrian friendly with a variety of experiences along the street's edge. It emphasizes an urban experience along a multi-nodal corridor. The EDG 2 proposal considers the future life of the building by providing ways to adjust street level uses and proposes a cohesive facade concept on all sides for the in-fill site. The concept increased space for people to live by reconsidering an enclosed garage and back of house space as an open-air space for residents at the street level.

Additionally, EDG 2:

Reconfigured the residential floor levels to maximize units along the facades by relocating vertical circulation and services to the interior of the floor plate, thus reducing a sense of height, bulk, and scale on the street facade.

The south access point is imagined as a prominent building entry rather than a garage entry and is separated from the service access to the north.

Removes at grade units and terraces along the west facade to allow for more openness and respect for adjacent sites

Increases the ROW an additional 7'-8" +/- from the 4'-0" ROW setback to add planting and street variety.

Considered ways to introduce the potential for a future retail kiosk space at the street level for the changing needs of the building over time.

Although not required by zoning, EDG 2 proposes overhead weather protection between 8'-0" and 13'-0" above the sidewalk.

Proposes all required by zoning residential amenity are located on a roof level terrace which is setback from the building edges to respect adjacent neighbors.

SUMMARY



Unless otherwise indicated, all documents by HEWITT are © HEWITT.
This document and the ideas incorporated herein, as an instrument of professional service, are the property of HEWITT Architects, Inc. and are not to be used, reproduced or transmitted, in the whole or in part, in any form by any means without prior written authorization of HEWITT.

© HEWITT, 2022