

SDCI Project: #3037729-EG Lot A  
#3038298-EG Lot B  
#6821849-CN  
#6847710-CN

Dropped Off: 07/23/2021



Project Information	<b>3</b>
Public Outreach	<b>4</b>
Site Survey	<b>6</b>
Context & Zoning Analysis	<b>8</b>
Design Guidelines	<b>12</b>
Architectural Concept	<b>13</b>
Lighting Concept	<b>15</b>
Adjacency Diagrams	<b>16</b>
Concept Renderings	<b>22</b>

<u>Project Data</u>		<u>Key Metrics</u>		<u>Current - Lot A</u>	<u>Previously - Lot A</u>	<u>Current - Lot B</u>	<u>Previously - Lot B</u>
<b>Address:</b>	1127 NW 60th St Seattle, WA 98107	<b>Zone:</b>	LR1 (M1)	SF 5000	LR1 (M1)	SF 5000	
<b>Tax ID Number:</b>	2706770-4855	<b>Urban Village:</b>	Ballard (Residential)	Ballard (Residential)	Ballard (Residential)	Ballard (Residential)	
<b>SDCI Project Number:</b>	#3037729-EG #6821849-CN	<b>Frequent Transit:</b>	Yes		Yes		
<b>Lot Size:</b>	5,000 SF	<b>Overlay Zoning:</b>	No		No		
<b>Architect:</b>	Julian Weber Architects, LTD. 1257 S. King St. Seattle, WA 98144						
<b>Owner/Applicant:</b>	Keystone NW Investments, LLC 15600 NE 8th St, STE B1-126 Bellevue, WA 98008						
<b>Proposal:</b>	1127 NW 60th St is currently (1) lot with (1) SFR. The applicant proposes a shortplat into 2 parcels and then to demo the SFR, and construct (2) rowhouses and (2) townhouses with (4) open parking stalls and (2) future unit lot subdivisions.						
			<b>Required/Allowed</b>	<b>Proposed</b>	<b>Required/Allowed</b>	<b>Proposed</b>	
		<b>Density:</b>	RH'S - Unlimited	(2) Rowhouses	TH'S - Unlimited	(2) Townhouses	
		<b>Vehicle Parking:</b>	(0) Spaces	(2) Open Stalls	(0) Spaces	(2) Open Stalls	
		<b>Bike Parking:</b>	Long-term: (1) Space per Dwelling Unit Short-term: (1) Space per 10,000 SF	(2) Long-term  (1) Short-term	Long-term: (1) Space per Dwelling Unit Short-term: (1) Space per 10,000 SF	(2) Long-term  (1) Short-term	
		<b>FAR:</b>	1.3 X 2,500 SF =3,250 SF	3,178 SF	1.3 X 2,500 SF =3,250 SF	3,246 SF	
		<b>GFA (MHA Purposes)</b>	\$22.62/SF (M1, medium)	3,402.64 SF = \$76,967.72	\$22.62/SF (M1, medium)	3,558 SF = \$80,481.96	
		<b>Amenity Area:</b>	25% of Lot Area = 625 SF	872 SF	25% of Lot Area = 625 SF	934 SF	
		<b>Structure Height:</b>	30'-0" + 4' Parapet + 10' Penthouse Bonus	29'6" + 4' Parapet	30'-0" + 4' Parapet + 10' Penthouse Bonus	29'2" + 4' Parapet	
		<b>Front Setback (NW 60th St):</b>	5' Min	6.5'	5' Min, 7' Avg	13' 1/2"	
		<b>Rear Setback (South):</b>	5' Min, 7' Avg	11'	5' Min, 7' Avg	8'	
		<b>Side Setback (East):</b>	3.5' Min	10.5'	5' Min	5'	
		<b>Side Setback (West):</b>	3.5' Min	3.5'	5' Min	5' 1/2"	
		<b>Facade Length (East):</b>	65% (Within 15' of Property Line) 50' X .65 = 32.5'	Proposed: 36'	65% (Within 15' of Property Line) 50' X .65 = 32.5'	Proposed: 39'-11.5"	
		<b>Facade Length (West):</b>	65% (Within 15' of Property Line) 50' X .65 = 32.5'	Proposed: 36'	65% (Within 15' of Property Line) 50' X .65 = 32.5'	Proposed: 39'-11.5"	

HIGH-IMPACT METHOD:

We distributed flyers in a 500 foot radius from the site. Flyers were mailed to all residences within this area. Flyers provided information about the project and location, as well as a link to the project website and online survey.

Dear Resident, this flyer is to include you in a

## PROJECT UNDER DESIGN REVIEW

at 1127 NW 60th Street

Keystone Investments NW and JW Architects are collaborating to design the redevelopment of 1127 NW 60th St.



**Project information:**  
This project will be located midblock on the south side of NW 60th St. When it's complete, the new homes will be 3 stories tall and will include 2 Rowhouses and 2 Townhomes with 4 open air parking stalls. We're just getting started planning now – construction could start in Summer 2022 and the building could be open as early as Spring 2023.

**Project Contact:**  
Julian Weber, Founding Principal, JW Architects  
outreach@jwaseattle.com

We request your input through:

**ONLINE SURVEY**  
January 29th - February 19th, 2021  
Link to survey:  
[www.jwaseattle.com/1127nw](http://www.jwaseattle.com/1127nw)

**PROJECT WEBSITE**  
Link to website:  
<https://jwaseattleoutreach.wixsite.com/1127nw>

\*additional info on back of flyer



Front page of Flyer.

Link to project website and survey.

Link to dedicated project website and public comments.

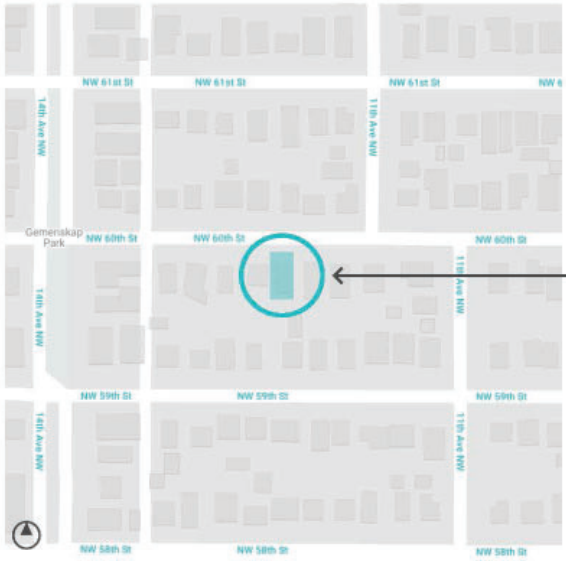

**ONLINE SURVEY**  
January 29th - February 19th, 2021  
Link to survey:  
[www.jwaseattle.com/1127nw](http://www.jwaseattle.com/1127nw)

Site: 1127 NW 60th St

\*In person event is shifted to online interaction due to public health concern and City requirements by Seattle Department of Neighborhood

To find out more about this project and share your thoughts on the future of the project, please visit JW Architects website ([www.jwaseattle.com](http://www.jwaseattle.com)) and respond with your comments on the project website (<https://jwaseattleoutreach.wixsite.com/1127nw>).

More information about early outreach for design review can be found on the Seattle Department of Neighborhood's web page (<http://www.seattle.gov/neighborhoods>).

All information is being collected by JW Architects, but may be submitted to the City of Seattle. Therefore, personal information entered may be subject to disclosure to a third-party requestor pursuant to the Washington Public Records Act.

What type of feedback is the Design Review looking for?

- Reference unique neighborhood features and character
- Architectural design
- Building forms and materials
- Sidewalk experience
- Screening for privacy



Back page of Flyer.

Approved by the Department of Neighborhoods on 04/01/2021



# Development Objectives & Public Outreach

## DESIGN REVIEW OUTREACH SURVEY

Keystone Investments and JW Architects are collaborating to design the redevelopment of 1127 NW 60th St. When it's complete, the new homes will be 3 stories tall and will include 2 Rowhouses and 2 Townhomes with 4 open air parking stalls. We're just getting started planning now – construction could start in Summer 2021 and the building could be open as early as Winter 2022.

Please share your thoughts with us on the project website, (<https://waseattleoutreach.wikisite.com/9025>) and provide feedback on how to make this a successful development in the Crown Hill neighborhood. The website will be available January 29th – February 19th, 2021.

This survey will be open from January 29th – February 19th, 2021. After that, we'll start preparing for the City's Design Review process and other permitting steps.

To find out more about this project and track our progress through the design review and permitting process, search the project address (1127 NW 60<sup>th</sup> Street) in the [Design Review Calendar](#) and the [Seattle Services Portal](#). To find out more about early outreach for design review, visit the [Department of Neighborhood's webpage](#).

This survey is anonymous, though information you share could be made public. Please do not share any personal/sensitive information. All information is being collected by JW Architects, but may be submitted to the City of Seattle. Therefore, personal information entered may be subject to disclosure to a third-party requestor pursuant to the Washington Public Records Act.

### Questions:

1. What is your connection to this development project? (select all that apply)
  - I live very close to the project
  - I live in the general area
  - I own a business nearby
  - I visit the area often for work or leisure
  - I don't have a direct connection, but I care about growth and development in Seattle
  - Other [fill in blank, 100 character maximum]
2. What is most important to you about a new building on this property? (select up to two)
  - That it fits into neighborhood look
  - That it stands out as a unique and landmark building
  - That it brings new services or amenities to the area (businesses, open space, etc.)
  - That is affordable for residents and/or businesses
  - That it is designed to be family-friendly
  - That it is designed with environmental sustainability in mind
  - Other [fill in blank, 100 character maximum]

3. We will be improving the sidewalks and landscaping at the street-level. What design features do you prefer? (select up to two)
  - Lots of plants/greenery
  - Additional designs for safety (street lighting, gates, fences, etc)
  - Quality building materials at street-level (brick, large windows,
  - Seating/places to congregate (sidewalk cafes, benches, etc)
  - Pet friendly areas
  - Off-street bicycle parking
  - Other [fill in blank, 100 character maximum]
4. What concerns do you have about the project? (select any/all that apply)
  - Construction noise/impacts
  - The existing residence is going away
  - That I will not like the way it looks
  - That it will not be affordable
  - That it may feel out of scale with other buildings nearby
  - I don't really have any specific concerns
  - Other [fill in blank, 100 character maximum]
5. Is there anything specific about this property or neighborhood that would be important for us to know?  
[fill in blank, 300 character maximum]
6. What are some landmarks/spaces that help to identify your neighborhood?  
[fill in blank, 300 character maximum]
7. What do you like most about living or working in your neighborhood?  
[fill in blank, 300 character maximum]
8. What do you like least about living/working in your neighborhood?  
[fill in blank, 300 character maximum]

### Additional questions to help us analyze the survey results:

1. What is your age?
  - Under 12 years old
  - 12-17 years old
  - 18-24 years old
  - 25-34 years old
  - 35-44 years old
  - 45-54 years old

- 55-64 years old
- 65-74 years old
- 75 years or older

2. What are the languages spoken in your home? (select any/all that apply)
  - English
  - Spanish
  - Amharic
  - Oromo
  - Tigrinya
  - Other [please specify]
3. How long have you lived in this neighborhood?
  - Less than a year
  - 1-2 years
  - 3-5 years
  - 5-10 years
  - 10-15 years
  - More than 15 years
  - I do not live in this neighborhood

Thank you for sharing feedback about our project! Your input is helpful for us to hear as we start to plan for the new building.

To find out more about this project and track our progress through the design review and permitting process, search the project address (1127 NW 60<sup>th</sup> Street) in the [Design Review Calendar](#) and the [Seattle Services Portal](#).

If you don't want to respond to the survey but do want to share your thoughts, or you have any other project-related thoughts or ideas to share, the contact person for the project is Julian Weber at [outreach@waseattle.com](mailto:outreach@waseattle.com)

## SURVEY RESULTS

We received 12 surveys. All were completed through our online survey via the link provided on our printed outreach flyer. Percentages are based on the information completed. Not all surveys had all questions answered.

### Question 1:

8% visit the area often for work or leisure  
92% live very close to the project

### Question 2:

83% want it to fit into neighborhood look  
8% want it to bring new services or amenities to the area  
16.5% want it to be affordable for residents and/or businesses  
16.5% want it designed to be family-friendly  
16.5% want it to be designed with environmental sustainability in mind

### Other comments:

- "Already going to stand out on our street that's all 100 year old homes just don't make it ugly too"
- "I do not want a single home replaced with multiple row houses or town homes"

### Question 3:

75% want lots of plants/greenery  
25% want additional designs for safety  
25% want quality building materials at street-level  
8% want seating/places to congregate

8% want pet friendly areas

### other comment:

- Set back from the street and adjacent properties so that there is open space on front and sides

### Question 4:

41.5% are concerned with construction noise/impacts  
41.5% are concerned with the existing residence going away  
66.5% are concerned with not liking the way it looks  
25% are concerned it will not be affordable  
75% are concerned with it feeling out of scale

### Other comment:

- "Impacts to street parking and more utility/working vans = more casing and theft"

### Question 5:

- It is surrounded by single family homes so it will destroy the neighborhood look and feel  
- We have seen what has happened to the west of us with the emphasis on density. Keep it west of 15th NW and spare us  
- People move out of townhouses when they age or when they have kids. Why not build a small condo with fewer stairs per unit – somewhere people can age in place and still walk to all the amenities Ballard has to offer? Please make a place for garbage that is not on the street facing side  
- Lots of new similar buildings going up in this area, some are ugly and look like they are from the 90s. There aren't many public trash cans around, would be good to add one. I walk my dog around here and can never find a place to toss the bags  
- Don't build your ugly modern lime green townhomes  
- Too many perfectly good single family homes are being sacrificed for three story boxes being built. They don't fit in with the neighborhood

### Question 6:

- Gemenskap Park  
- The "poop and pee" dog park at the corner  
- Brick buildings, older craftsman styling  
- Ballard market, gemenskap park, little free libraries  
- Well maintained old homes, beautiful landscaping, park at 14th street

### Question 7:

- Friendly neighbors and walkability  
- People who feel attached to the neighborhood and who actually know each other  
- Neighbors who are connected to each other and care, walkability, greenery from houses and gardens, amenities nearby

- It feels suburb-y but is in the city. The history and charm of the craftsman homes  
- Convenient, everything is walkable, it's quiet but close to bars, restaurants, breweries, shops  
- Families living in single family homes  
- Highly walkable, pet-friendly, lots of recreational options  
- Single family homes  
- Family friendly, safety

### Question 8:

- The classic bungalows are being destroyed  
- Creeping density with houses/buildings designed by engineers with no architectural sensitivity or talent  
- All the people moving in and new development that is unaffordable, parking issues, crime and break-ins, finding needles in the parks and on the parking strips, loss of daylight due to massicely tall development, construction noise  
- Homelessness, drug use and abuse, casing and theft  
- Getting expensive, no public trash cans  
- All the ugly modern townhomes being built  
- Petty crime, rampant homelessness  
- The perfectly good family homes are being demolished in favor of multi family places. And the lack of parking off street

### Additional results:

Question 1:  
41.5% were 25-34 years old  
8% were 35-44 years old  
8% were 45-54 years old  
25% were 55-64 years old  
16.5% were 65-74 years old

Question 2:  
100% English

Question 3:  
41.5% 0-5 years  
8% 5-10 years  
41.5% more than 15 years

# Development Objectives & Public Outreach

# TOPOGRAPHIC & BOUNDARY SURVEY

<b>LEGAL DESCRIPTION</b>																																																																																												
LOT 7, BLOCK 92, GILMAN PARK, ACCORDING TO THE PLAT THEREOF FILED IN VOLUME 3 OF PLATS AT PAGE(S) 40 AND 41, RECORDS OF KING COUNTY WASHINGTON.																																																																																												
<b>BASIS OF BEARINGS</b>																																																																																												
NAD 83(2011) WASHINGTON NORTH STATE PLANE COORDINATES PER GPS OBSERVATIONS																																																																																												
<b>REFERENCES</b>																																																																																												
R1. SHORT SUBDIVISION REC. NO. 2002121090014 RECORD OF SURVEY, VOL. 156, PG. 238-238D, RECORDS OF KING COUNTY, WASHINGTON.																																																																																												
R2. SHORT SUBDIVISION REC. NO. 20201006900002 RECORD OF SURVEY, VOL. 433, PG. 254-256, RECORDS OF KING COUNTY, WASHINGTON.																																																																																												
<b>VERTICAL DATUM</b>																																																																																												
NAVD 88 PER CITY OF SEATTLE BENCHMARK NO. SMP 8-05.																																																																																												
2IN BC STAMPED SMP 8-05 IN CW AT NE COR NW 59TH ST & 15TH AVE NW																																																																																												
ELEV.=106.962'																																																																																												
<b>SURVEYOR'S NOTES</b>																																																																																												
<ol style="list-style-type: none"> <li>1. THE TOPOGRAPHIC SURVEY SHOWN HEREON WAS PERFORMED IN NOVEMBER OF 2020. THE FIELD DATA WAS COLLECTED AND RECORDED ON MAGNETIC MEDIA THROUGH AN ELECTRONIC THEODOLITE. THE DATA FILE IS ARCHIVED ON DISC OR CD. WRITTEN FIELD NOTES MAY NOT EXIST. CONTOURS ARE SHOWN FOR CONVENIENCE ONLY. DESIGN SHOULD RELY ON SPOT ELEVATIONS.</li> <li>2. ALL MONUMENTS SHOWN HEREON WERE LOCATED DURING THE COURSE OF THIS SURVEY UNLESS OTHERWISE NOTED.</li> <li>3. THE TYPES AND LOCATIONS OF ANY UTILITIES SHOWN ON THIS DRAWING ARE BASED ON INFORMATION PROVIDED TO US, BY OTHERS OR GENERAL INFORMATION READILY AVAILABLE IN THE PUBLIC DOMAIN INCLUDING, AS APPLICABLE, IDENTIFYING MARKINGS PLACED BY UTILITY LOCATE SERVICES AND OBSERVED BY TERRANE IN THE FIELD. AS SUCH, THE UTILITY INFORMATION SHOWN ON THESE DRAWINGS ARE FOR INFORMATIONAL PURPOSES ONLY AND SHOULD NOT BE RELIED ON FOR DESIGN OR CONSTRUCTION PURPOSES; TERRANE IS NOT RESPONSIBLE OR LIABLE FOR THE ACCURACY OR COMPLETENESS OF THIS UTILITY INFORMATION. FOR THE ACCURATE LOCATION AND TYPE OF UTILITIES NECESSARY FOR DESIGN AND CONSTRUCTION, PLEASE CONTACT THE SITE OWNER AND THE LOCAL UTILITY LOCATE SERVICE (800-424-5555).</li> <li>4. SUBJECT PROPERTY TAX PARCEL NO. 2767704855</li> <li>5. SUBJECT PROPERTY AREA PER THIS SURVEY IS 5,003 S.F. (0.11 ACRES)</li> <li>6. THIS SURVEY WAS PERFORMED WITHOUT THE BENEFIT OF A TITLE REPORT, EASEMENTS AND OTHER ENCUMBRANCES MAY EXIST THAT ARE NOT SHOWN HEREON.</li> <li>7. FIELD DATA FOR THIS SURVEY WAS OBTAINED BY DIRECT FIELD MEASUREMENTS WITH A CALIBRATED ELECTRONIC 5-SECOND TOTAL STATION AND/OR SURVEY GRADE GPS OBSERVATIONS. ALL ANGULAR AND LINEAR RELATIONSHIPS ARE ACCURATE AND MEET THE STANDARDS SET BY WAC 332-130-090.</li> </ol>																																																																																												
<b>LEGEND</b>																																																																																												
<table border="0"> <tr> <td></td> <td>BENCHMARK</td> <td></td> <td>BLDG BUILDING</td> </tr> <tr> <td></td> <td>CENTERLINE ROW</td> <td></td> <td>C.C. CALCULATED</td> </tr> <tr> <td></td> <td>CONCRETE SURFACE</td> <td></td> <td>CITY OF SEATTLE</td> </tr> <tr> <td></td> <td>RETAINING WALL</td> <td></td> <td>CONC CONCRETE</td> </tr> <tr> <td></td> <td>DECK</td> <td></td> <td>COR CORNER</td> </tr> <tr> <td></td> <td>FENCE LINE (WOOD)</td> <td></td> <td>DEC DECIDUOUS</td> </tr> <tr> <td></td> <td>FIRE HYDRANT</td> <td></td> <td>ELEV ELEVATION</td> </tr> <tr> <td></td> <td>GAS LINE</td> <td></td> <td>EVG EVERGREEN</td> </tr> <tr> <td></td> <td>GAS METER</td> <td></td> <td>FF FINISH FLOOR</td> </tr> <tr> <td></td> <td>NAIL AS NOTED</td> <td></td> <td>GAS GAS</td> </tr> <tr> <td></td> <td>MAILBOX (RESIDENTIAL)</td> <td></td> <td>LS# LAND SURVEYOR NUMBER</td> </tr> <tr> <td></td> <td>MONUMENT IN CASE (FOUND)</td> <td></td> <td>MEAS MEASURED</td> </tr> <tr> <td></td> <td>PAVER/BRICK SURFACE</td> <td></td> <td>MON MONUMENT</td> </tr> <tr> <td></td> <td>POWER METER</td> <td></td> <td>OHP OVERHEAD POWER</td> </tr> <tr> <td></td> <td>POWER (OVERHEAD)</td> <td></td> <td>PROP PROPERTY</td> </tr> <tr> <td></td> <td>POWER POLE W/ LIGHT</td> <td></td> <td>R RECORD DATA</td> </tr> <tr> <td></td> <td>REBAR AS NOTED (FOUND)</td> <td></td> <td>ROS RECORD OF SURVEY</td> </tr> <tr> <td></td> <td>REBAR &amp; CAP (SET)</td> <td></td> <td>SSMH SANITARY SEWER MANHOLE</td> </tr> <tr> <td></td> <td>SEWER LINE</td> <td></td> <td>SSS SANITARY SIDE SEWER</td> </tr> <tr> <td></td> <td>SEWER MANHOLE</td> <td></td> <td>SF SQUARE FEET</td> </tr> <tr> <td></td> <td>TREE (AS NOTED)</td> <td></td> <td></td> </tr> <tr> <td></td> <td>WATER LINE</td> <td></td> <td></td> </tr> <tr> <td></td> <td>WATER METER</td> <td></td> <td></td> </tr> </table>		BENCHMARK		BLDG BUILDING		CENTERLINE ROW		C.C. CALCULATED		CONCRETE SURFACE		CITY OF SEATTLE		RETAINING WALL		CONC CONCRETE		DECK		COR CORNER		FENCE LINE (WOOD)		DEC DECIDUOUS		FIRE HYDRANT		ELEV ELEVATION		GAS LINE		EVG EVERGREEN		GAS METER		FF FINISH FLOOR		NAIL AS NOTED		GAS GAS		MAILBOX (RESIDENTIAL)		LS# LAND SURVEYOR NUMBER		MONUMENT IN CASE (FOUND)		MEAS MEASURED		PAVER/BRICK SURFACE		MON MONUMENT		POWER METER		OHP OVERHEAD POWER		POWER (OVERHEAD)		PROP PROPERTY		POWER POLE W/ LIGHT		R RECORD DATA		REBAR AS NOTED (FOUND)		ROS RECORD OF SURVEY		REBAR & CAP (SET)		SSMH SANITARY SEWER MANHOLE		SEWER LINE		SSS SANITARY SIDE SEWER		SEWER MANHOLE		SF SQUARE FEET		TREE (AS NOTED)				WATER LINE				WATER METER		
	BENCHMARK		BLDG BUILDING																																																																																									
	CENTERLINE ROW		C.C. CALCULATED																																																																																									
	CONCRETE SURFACE		CITY OF SEATTLE																																																																																									
	RETAINING WALL		CONC CONCRETE																																																																																									
	DECK		COR CORNER																																																																																									
	FENCE LINE (WOOD)		DEC DECIDUOUS																																																																																									
	FIRE HYDRANT		ELEV ELEVATION																																																																																									
	GAS LINE		EVG EVERGREEN																																																																																									
	GAS METER		FF FINISH FLOOR																																																																																									
	NAIL AS NOTED		GAS GAS																																																																																									
	MAILBOX (RESIDENTIAL)		LS# LAND SURVEYOR NUMBER																																																																																									
	MONUMENT IN CASE (FOUND)		MEAS MEASURED																																																																																									
	PAVER/BRICK SURFACE		MON MONUMENT																																																																																									
	POWER METER		OHP OVERHEAD POWER																																																																																									
	POWER (OVERHEAD)		PROP PROPERTY																																																																																									
	POWER POLE W/ LIGHT		R RECORD DATA																																																																																									
	REBAR AS NOTED (FOUND)		ROS RECORD OF SURVEY																																																																																									
	REBAR & CAP (SET)		SSMH SANITARY SEWER MANHOLE																																																																																									
	SEWER LINE		SSS SANITARY SIDE SEWER																																																																																									
	SEWER MANHOLE		SF SQUARE FEET																																																																																									
	TREE (AS NOTED)																																																																																											
	WATER LINE																																																																																											
	WATER METER																																																																																											
<b>VICINITY MAP</b> N.T.S.																																																																																												

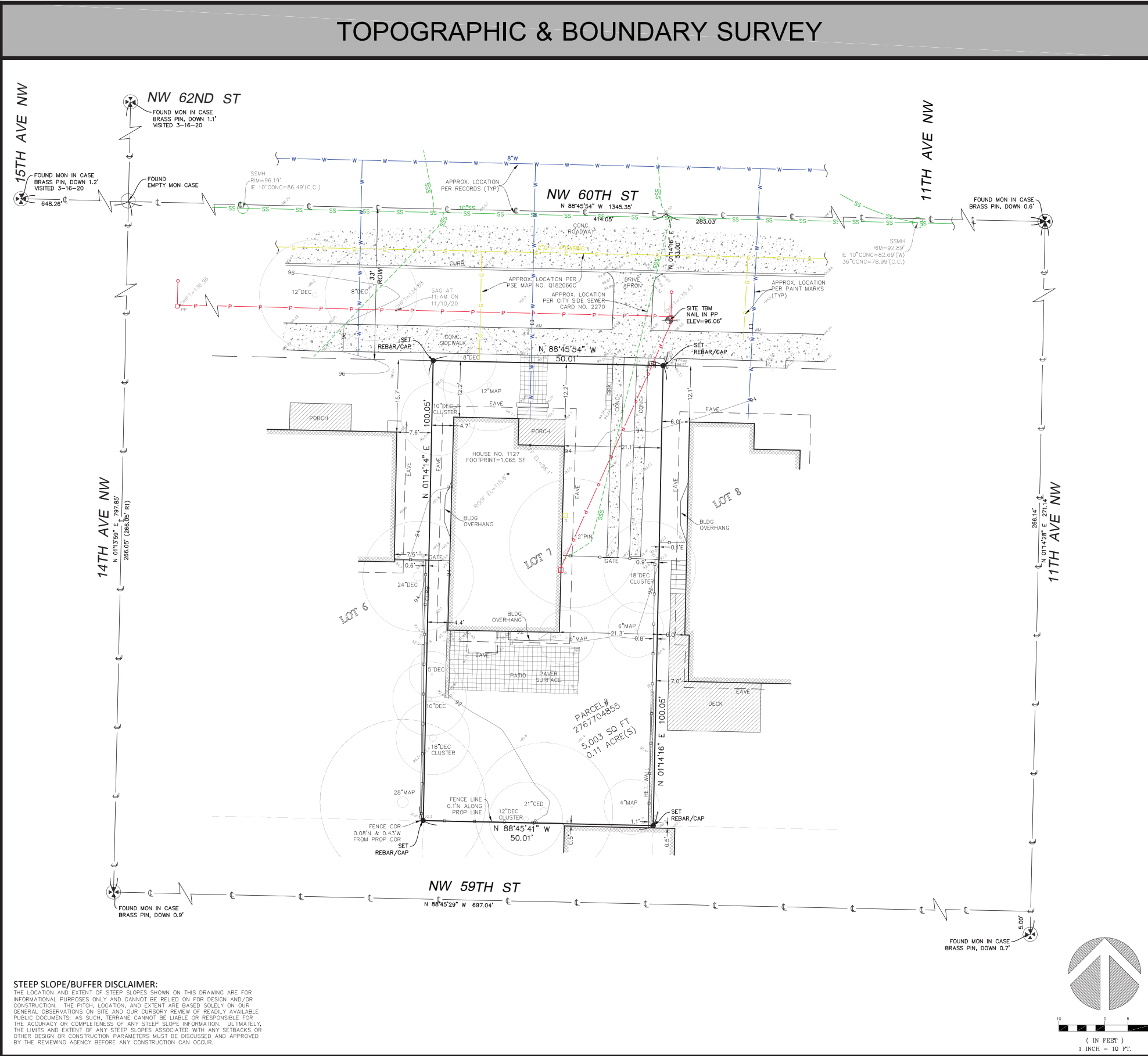

**measure success**

**TOPOGRAPHIC & BOUNDARY SURVEY**  
SW 1/4 OF NW 1/4 SEC 12, TWP. 25N., RGE 03E., W4M.  
PARCEL NO. 2767704855

**Keystone NW Investments, LLC**  
1127 NW 60th St  
SEATTLE, WA 98107

**Terrane**  
10801 Main Street, Suite 102, Bellevue, WA 98004  
phone 425.458.4488 support@terrane.net  
www.terrane.net

JOB NUMBER: 202027  
DATE: 11/16/20  
DRAFTED BY: JJK  
CHECKED BY: SRM  
SCALE: 1" = 10'  
REVISION HISTORY

SHEET NUMBER  
1 OF 1

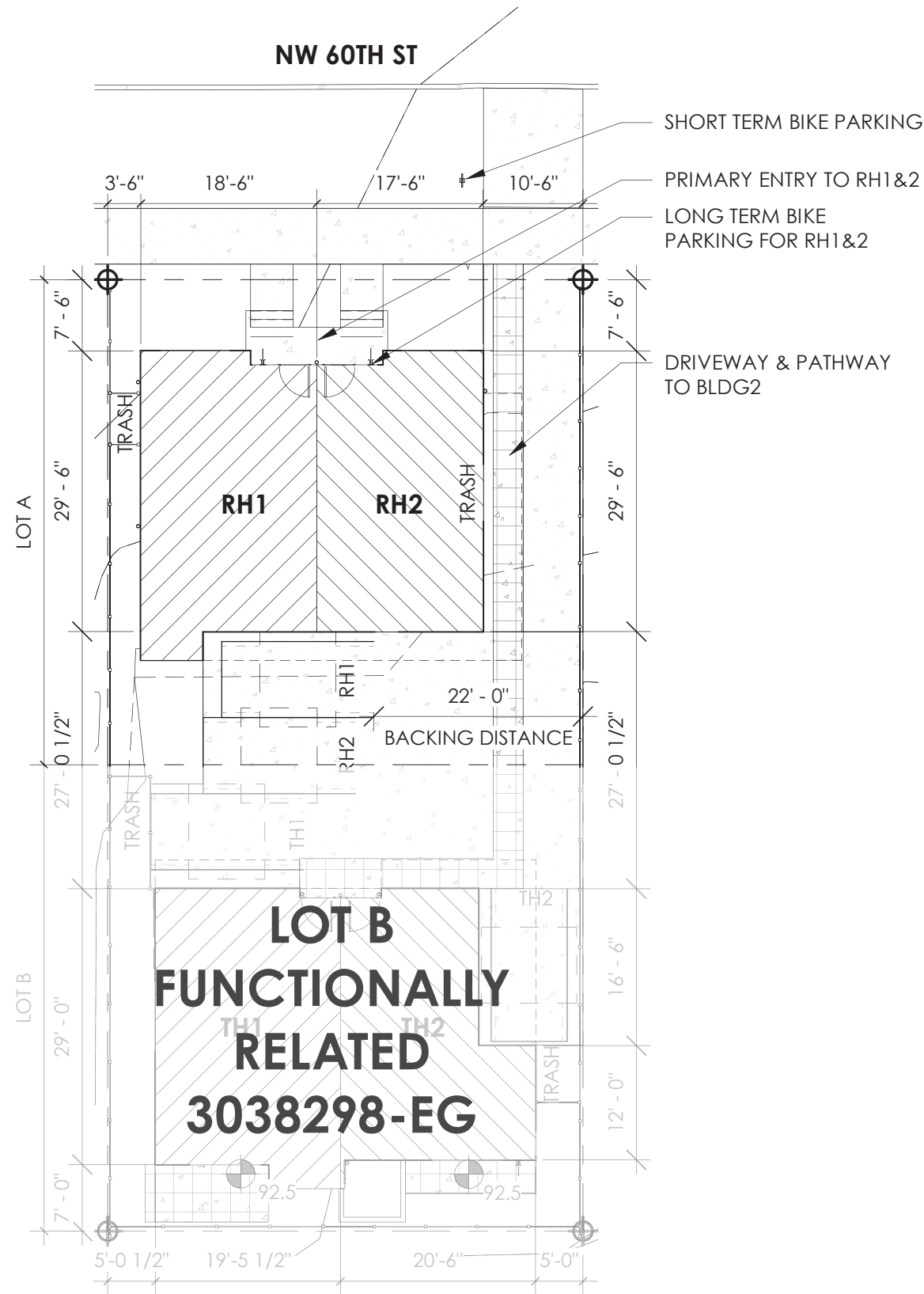

**FAR AREA CALCULATION (LOT A)**

RH1	
COVERED PARKING	36 SF
Level 1	490 SF
Level 2	543 SF
Level 3	493 SF
	1,562 SF

RH2	
COVERED PARKING	18 SF
Level 1	444 SF
Level 2	619 SF
Level 3	535 SF
	1,616 SF
TOTAL	3,178 SF

**FAR AREA CALCULATION (LOT B)**

TH1	
COVERED PARKING	37 SF
LEVEL 1	531 SF
LEVEL 2	573 SF
LEVEL 3	465 SF
	1,607 SF

TH2	
COVERED PARKING	99 SF
LEVEL 1	435 SF
LEVEL 2	579 SF
LEVEL 3	526 SF
	1,639 SF
TOTAL	3,246 SF

MHA/GFA - LOT A	
Name	Area
Level 1	1,089.03 SF
Level 2	1,261.04 SF
Level 3	1,052.57 SF
TOTAL	3,402.64 SF

MHA/GFA - LOT B	
Name	Area
Level 1	1,205.15 SF
Level 3	1,099.20 SF
Level 2	1,253.65 SF
TOTAL	3,558.00 SF

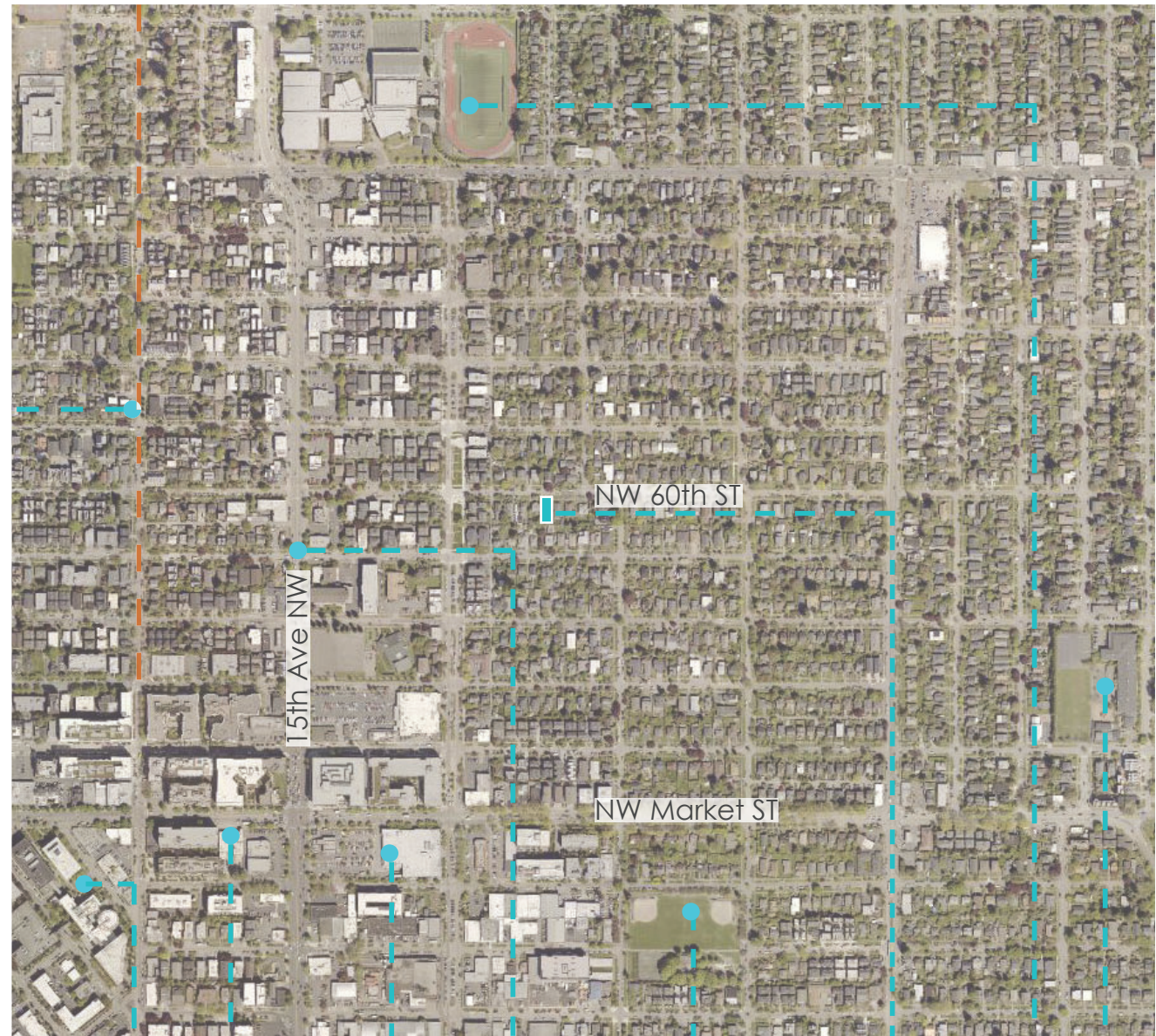
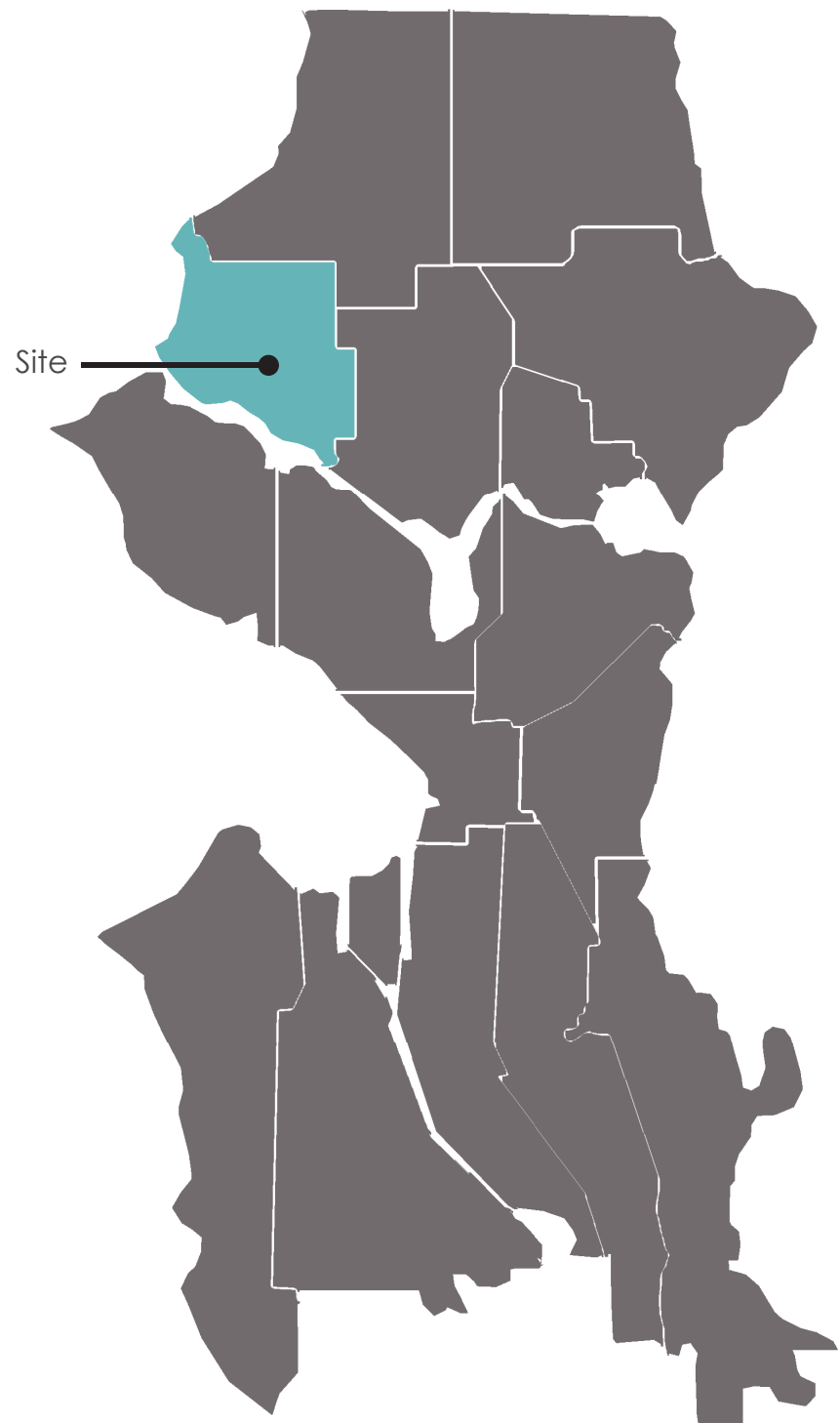



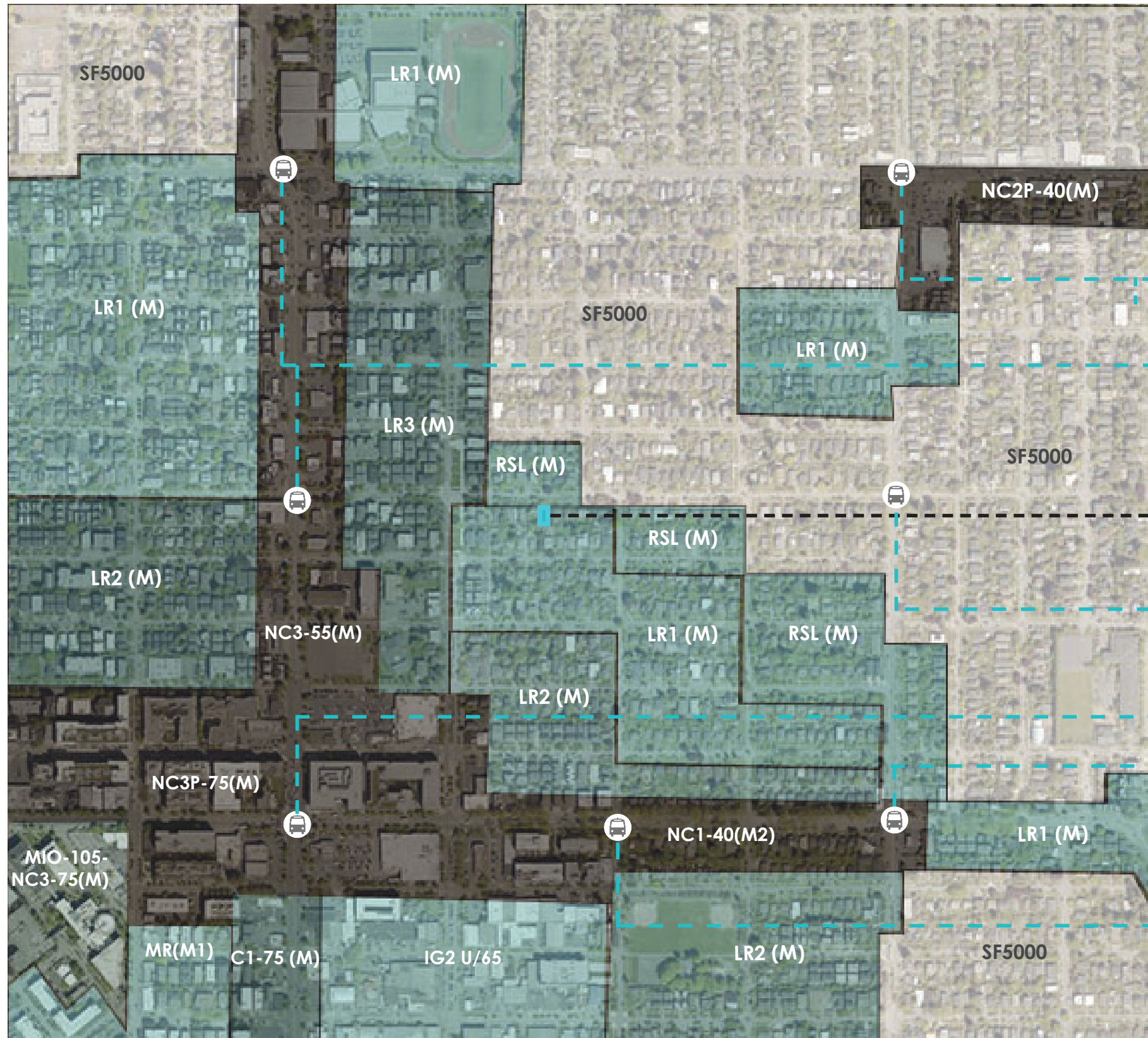

Project Site Zoning: LR1 (M1)

Adjacent Zoning: SF 5000, LR2(M), LR3(M), RSL(M)

Public Transportation: **Line 28**- 8th Ave NW & NW Market St

**Line 28**- 8th Ave NW & NW 61st St

**Line 28**- 8th Ave NW & NW 65th St

**Line 44**- 8th Ave NW & NW Market St

**Line 44**- 8th Ave NW & 11th Ave NW

**Line 44**- 8th Ave NW & 15th Ave NW

**Line D**- 15th Ave NW & NW Market St

**Line D**- 15th Ave NW & NW 60th St

**Line D**- 15th Ave NW & NW 65th St

**Key:**

- SF5000
- RSL (M)
- LR1
- LR2
- LR3
- NC

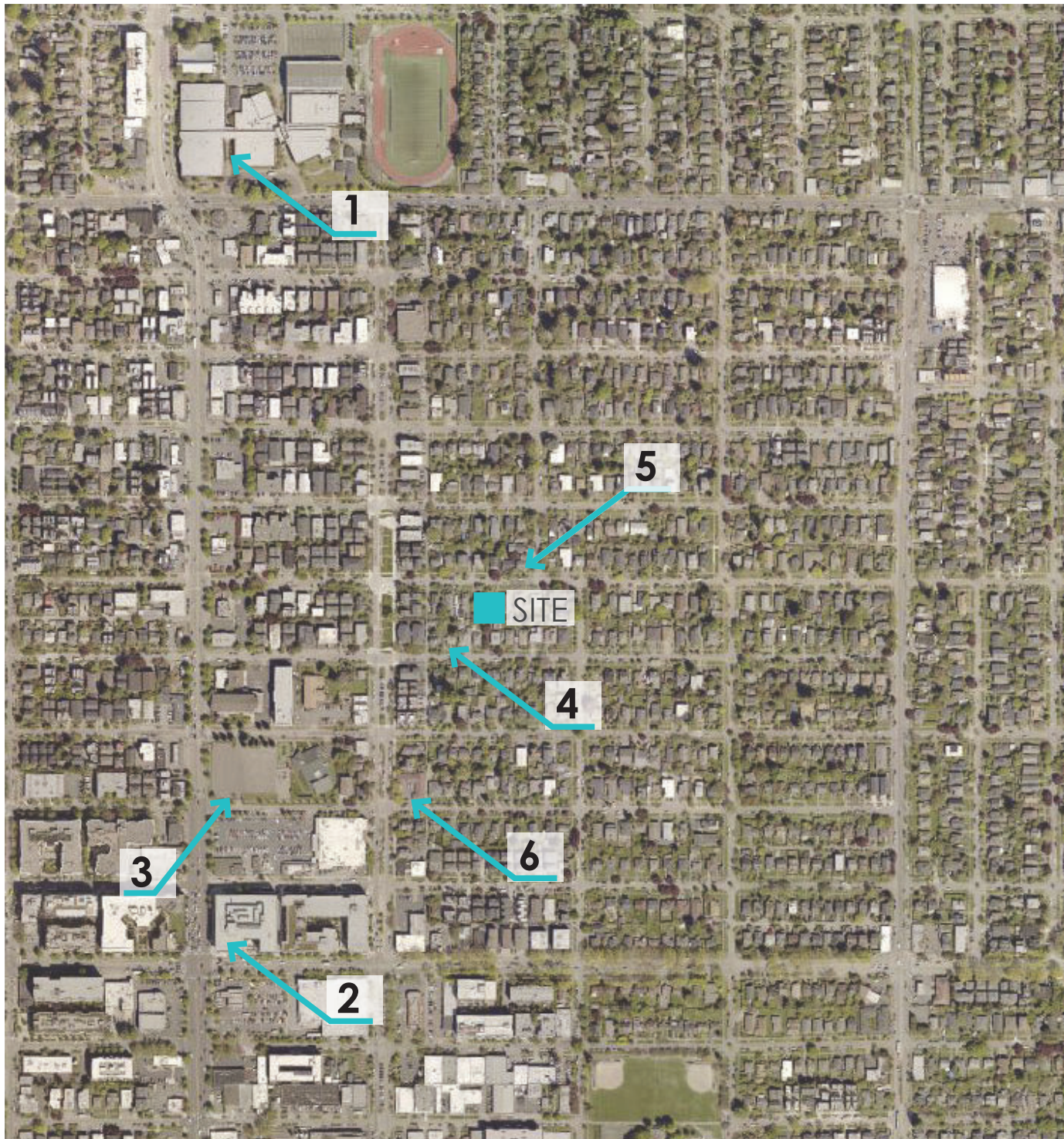

1. Ballard High School

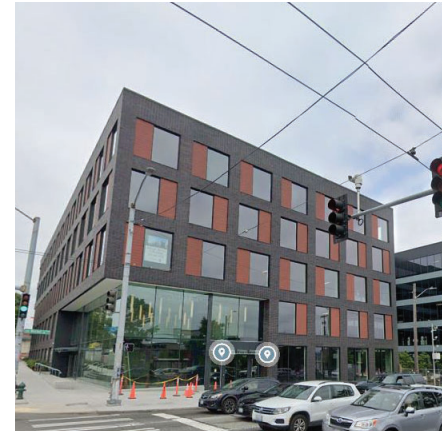

2. Target shopping center



3. St Alphonsus Church



4. 1140 NW 59th St Rowhouses (under construction)



5. 1102 NW 60th St



7. 1160 NW 58th St

**Neighborhood**

The project at 1127 NW 60th St is located in the transforming neighborhood of Ballard. The area is densifying as many of the single family sites are being transformed into townhomes and rowhomes to house our new neighbors. The neighborhood has traditional craftsman style homes, mixed with modern style construction projects. The main street along 15th Ave NW provides access to public transportation, shops, and restaurants to support the growing neighborhood.

NW 60th St Looking North

ACROSS  
FROM SITE



West

East

14th AVE NW

11th AVE NW

NW 60th St Looking South

SITE



East

West

11th AVE NW

14th AVE NW

<b>CS2. Urban Pattern and Form</b>	B. Adjacent Sites, Streets, and Open Spaces	<p>Planner Notes: Identify unique, positive characteristics of neighborhood &amp; reflect/extrapolate through design; create strong connection to street &amp; existing open spaces.</p> <p>Design Response: The project site is in a recently up-zoned area from SF5000 to LR1. The neighborhood contains single level craftsman houses with low slope gable and shed roofs on NW 60th St. While perpendicular to the site on the 14th Ave NW, there is a mix of craftsman homes and modern, flat roof row home and town homes. Our project responds directly by utilizing a complimentary color palette and scale. Whites and dark blue lap siding with cedar wood entries and black metal roofs will bring in contemporary materials while maintaining the character. The front building has low slope shed roofs and the rear building has low slope butterfly roofs adjacent to roof deck on each unit.</p>
<b>CS3. Architectural Context and Character</b>	A. Emphasizing Positive Neighborhood Attributes	<p>Planner Notes: Explore ways for new development to establish a positive and desirable context for others to build upon</p> <p>Design Response: Pulling inspiration from the surrounding context, this site includes a dual porch entry condition facing the street. The raised entry and the site topography allow for a semi sunken building, that delivered an appropriate scale to the surrounding homes in the neighborhood. The roof is a broken low slope shed roof that pulls from the traditional craftsman style with a modern finish.</p>
<b>PL1. Connectivity</b>	B. Walkways and Connections	<p>Planner Notes: Consider how to enliven area &amp; enable interaction with at pedestrian scale (seating, lighting, plantings, etc).</p> <p>Design Response: Along the front entry of the site, there is lively vegetation and a pedestrian path along a planting strip to the rear units. There are bioplanter allowing for separation of the two front yards, as well as in the back between the two back yards. Pathways are warm and well lit with down lights under awnings and cantilevered surfaces.</p>
<b>PL3. Street-Level Interaction</b>	A. Entries	<p>Planner Notes: Emphasize entry as semi-private space provide privacy &amp; security in a way that is welcoming &amp; identifiable).</p> <p>Design Response: The entries have been made full height with a cedar accent material. It is a break in the mass and providing a warm textured material at the most trafficked point into the building. The street entry is raised to create a porch condition. Concrete paver pathways lead directly from the street to the rear entries.</p>
<b>DC2. Architectural Concept</b>	D. Scale and Texture	<p>Planner Notes: Incorporate arch. elements with detail at human scale into overall consistent design concept; provide "texture" through form, scale and materials.</p> <p>Design Response: The project uses lap and cedar throughout the project which ties back to the neighborhood. Panel is utilized in key areas as an accent material. Standing seem roofs will bring in a premium material to the neighborhood for its durability and long-lasting look.</p>

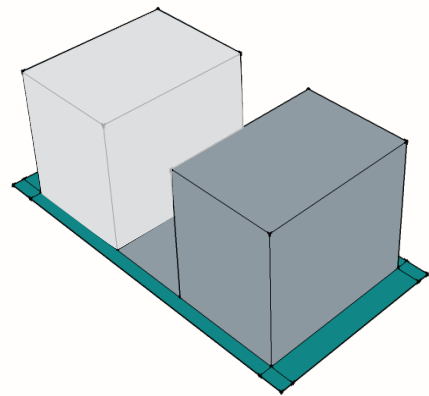

### 1. Engage the site

To keep the proposed project site in scale with the neighborhood, a (2) building scheme was selected. A rowhouse building engaging the street with a townhouse building in the rear with small private yards.

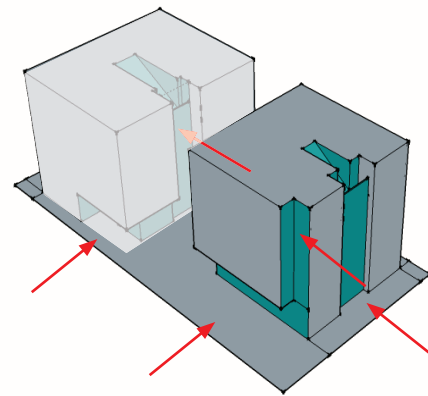

### 2. Reduce the Mass

Breaking down the perceived mass is a key driver to the building's articulation. The row house building has a split entry with a recessed 3rd story. Cantilevering over the parking area reclaims crucial yard areas. Level 3 walk out to access the roof decks relieves the project site of penthouses or additional massing which add extra bulk and scale to the proposed site.

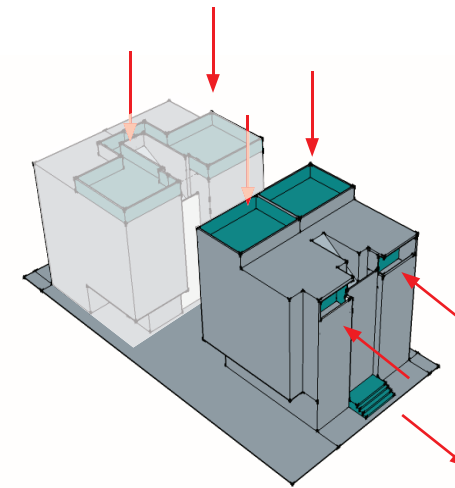

### 3. Engage the Street

A large combined raised front porch on the row house building continues the local theme of comfortable porches along the street.

Large decks off the master bedrooms front the street and the level 3 walk out to the roof provides more engagement to the street edge. Open gaurdrails increase transparency through out the site from the roof decks.

TH2's massing and roof deck articulation carefully looks back across the driveway and parking area.

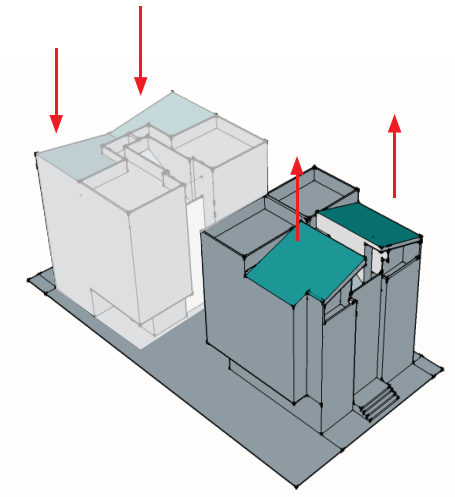

### 4. Maximize Open Space

All units have direct access to yard areas. The row houses have large front yards, while the townhouses have comfortable private rear yards.

All units have decks off the master bedrooms and roof decks with level 3 walk outs.

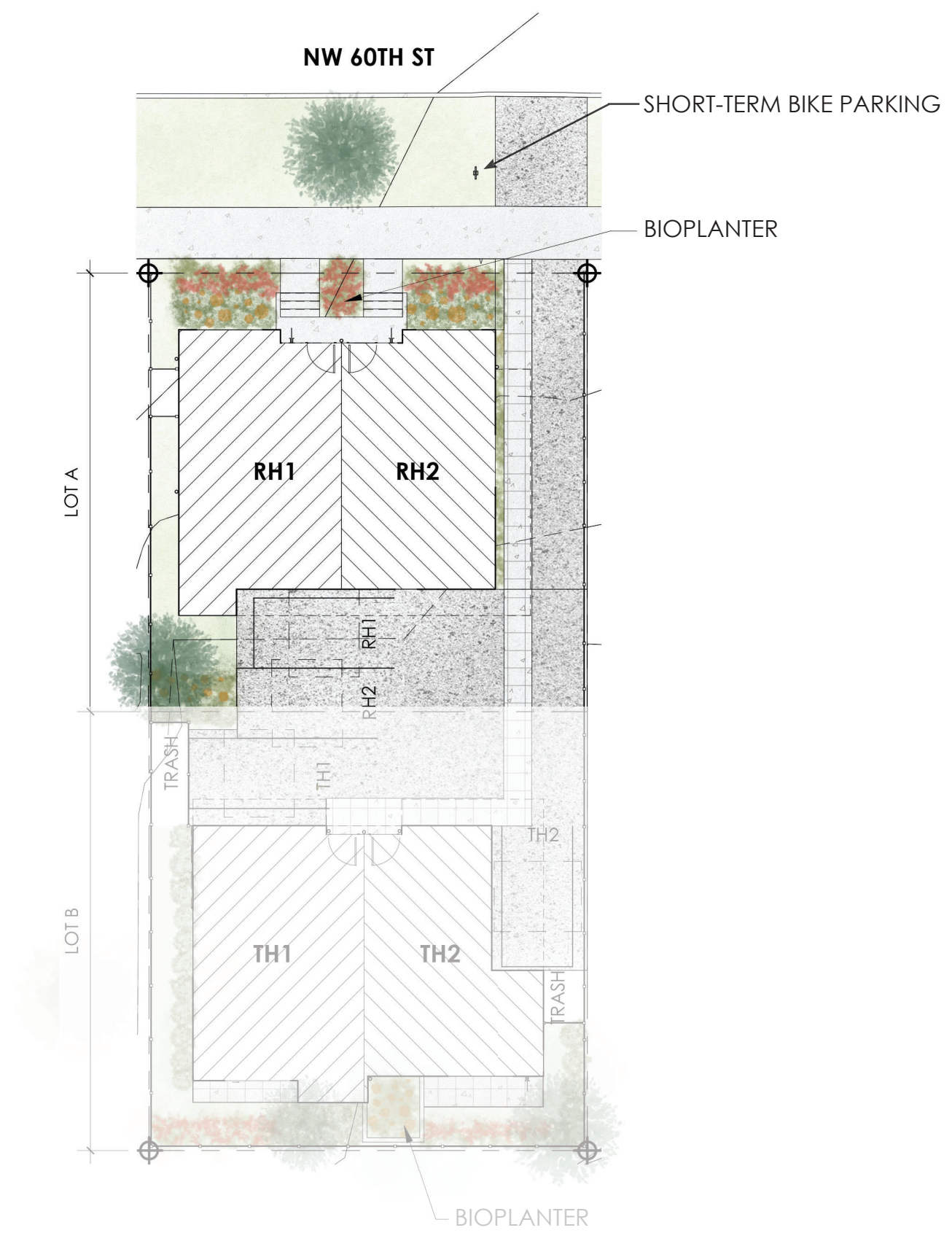

Scale: NTS

# Concept Landscape Plan

**LA** | SURFACE WALL MOUNT DOWN LIGHT  
LOCATION: ENTRIES THROUGHOUT



**SPECIFICATIONS**

<b>Construction:</b>	Die-cast Aluminum
<b>Power:</b>	30W, 16W
<b>Input:</b>	120-277 VAC, 50/60Hz
<b>Dimming:</b>	ELV: 100-15%, 0-10V: 100-10%
<b>Light Source:</b>	Integrated LED
<b>Rated Life:</b>	70000 Hours
<b>Mounting:</b>	Mounts directly to junction box, Can be mounted on wall in all orientations
<b>Finish:</b>	Electrostatically Powder Coated White, Electrostatically Powder Coated Bronze, Electrostatically Powder Coated Black, Electrostatically Powder Coated Brushed Aluminum, Electrostatically Powder Coated Graphite
<b>Operating Temp:</b>	-40°F to 122°F (-40°C to 50°C)
<b>Standards:</b>	ETL, cETL, Wet Location Listed, IP65, Title 24: 2019, Title 24:

**LC** | SURFACE MOUNT DOWNLIGHT  
LOCATION: BUILDING SOFFITS



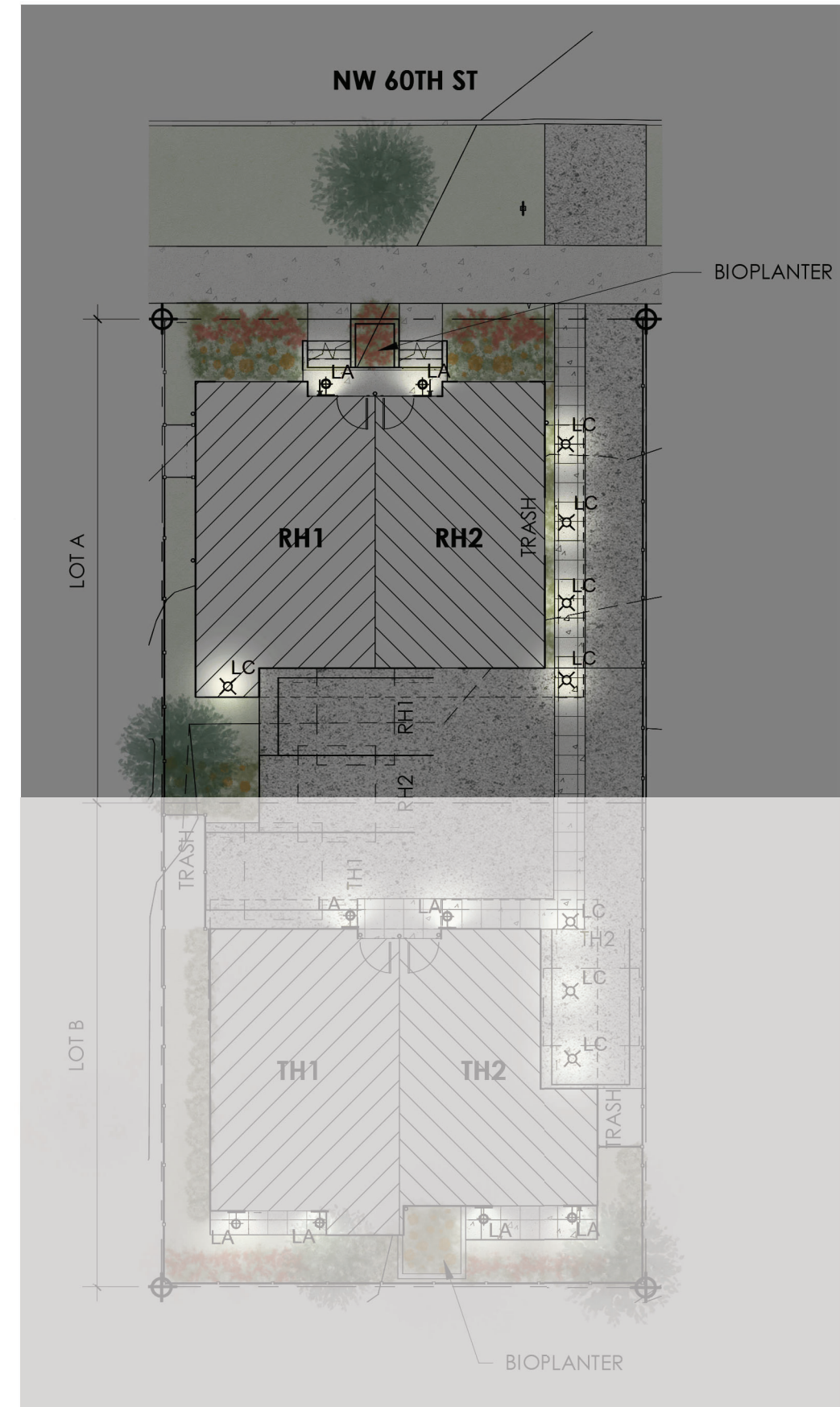

**SPECIFICATIONS**

<b>Construction:</b>	Die-cast Aluminum
<b>Power:</b>	16W, 30W
<b>Input:</b>	120 VAC, 120-277 VAC, 50/60Hz
<b>Dimming:</b>	ELV: 100-10%, 0-10V: 100-5%
<b>Light Source:</b>	Integrated LED
<b>Rated Life:</b>	70000 Hours
<b>Mounting:</b>	Mounts directly to junction box, Can be mounted on ceiling or wall in all orientations
<b>Finish:</b>	Electrostatically Powder Coated Brushed Aluminum, Electrostatically Powder Coated Black, Electrostatically Powder Coated Bronze, Electrostatically Powder Coated Graphite, Electrostatically Powder Coated White
<b>Operating Temp:</b>	-40°F to 122°F (-40°C to 50°C)
<b>Standards:</b>	ETL, cETL, Wet Location Listed, IP65, Title 24: 2019, Title 24:

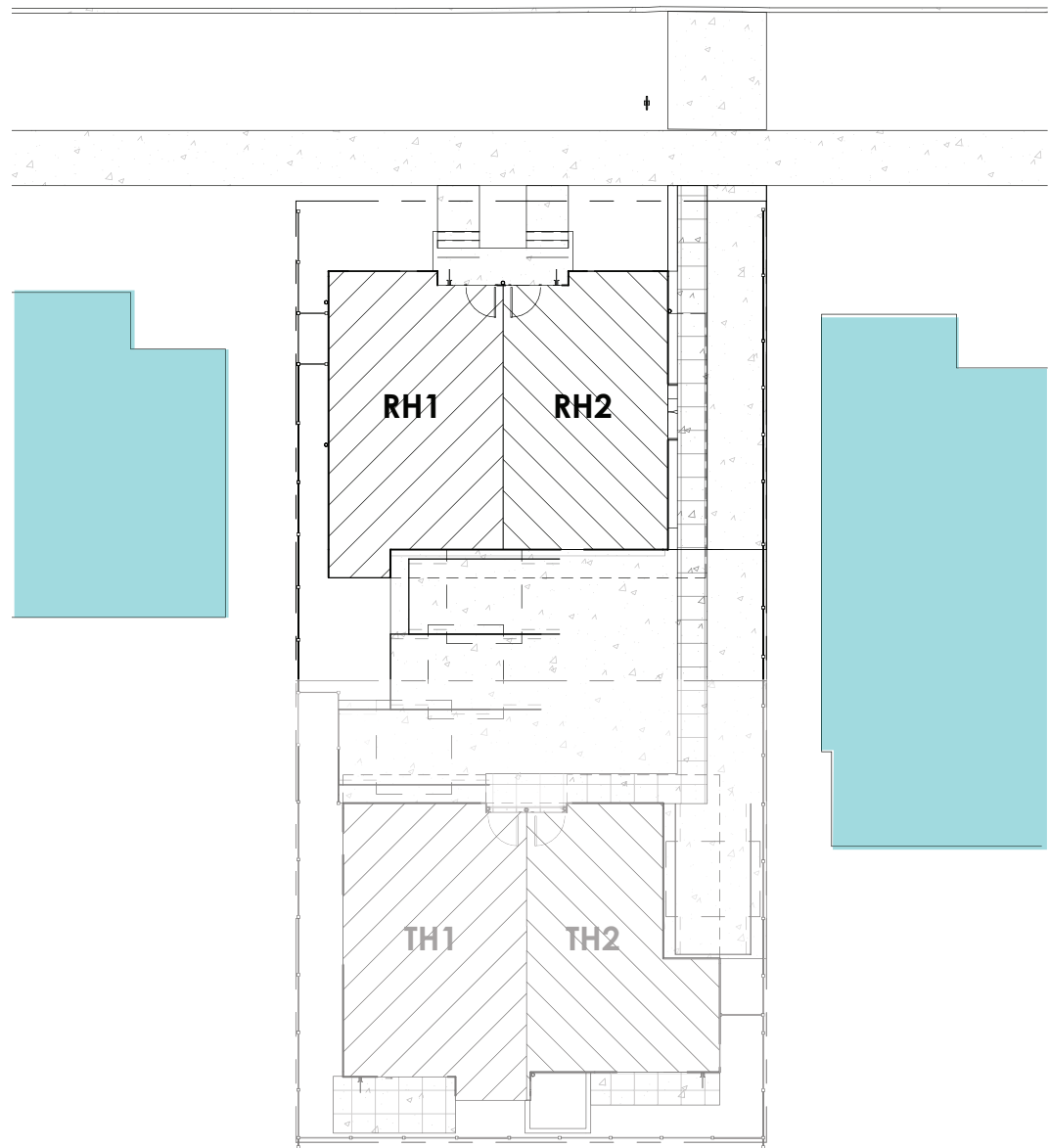



-  This area represents the windows on the adjacent properties.
-  This area represents the Building on the adjacent Properties

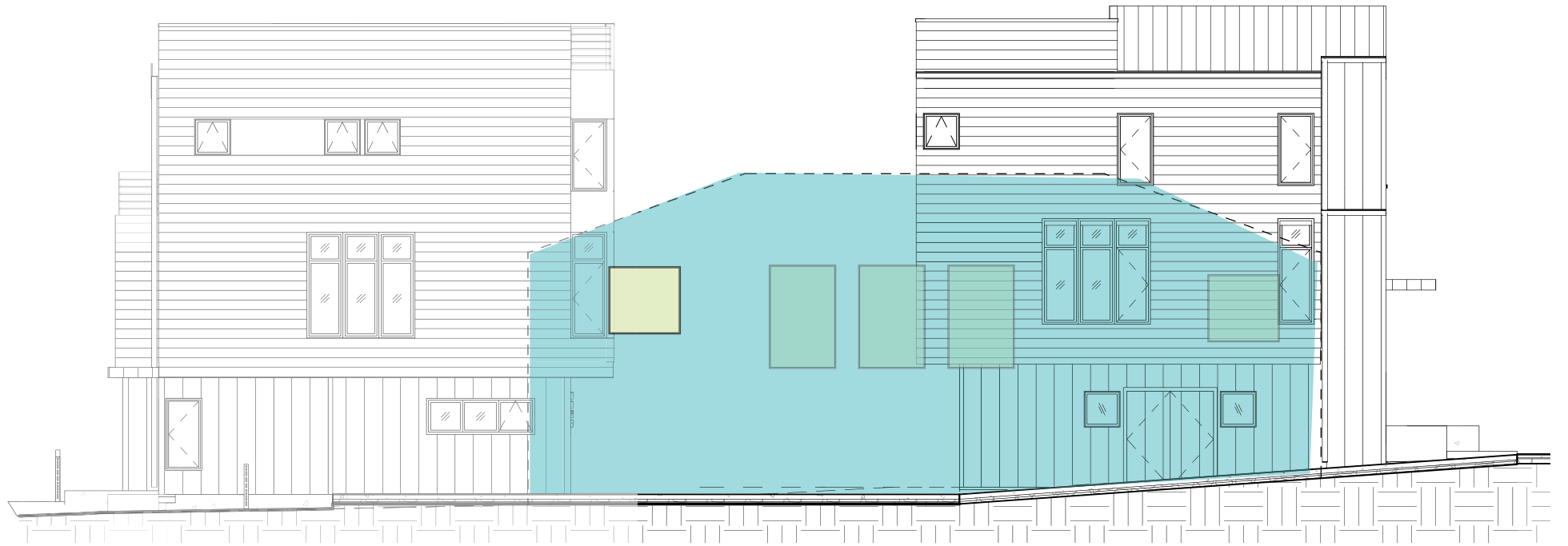



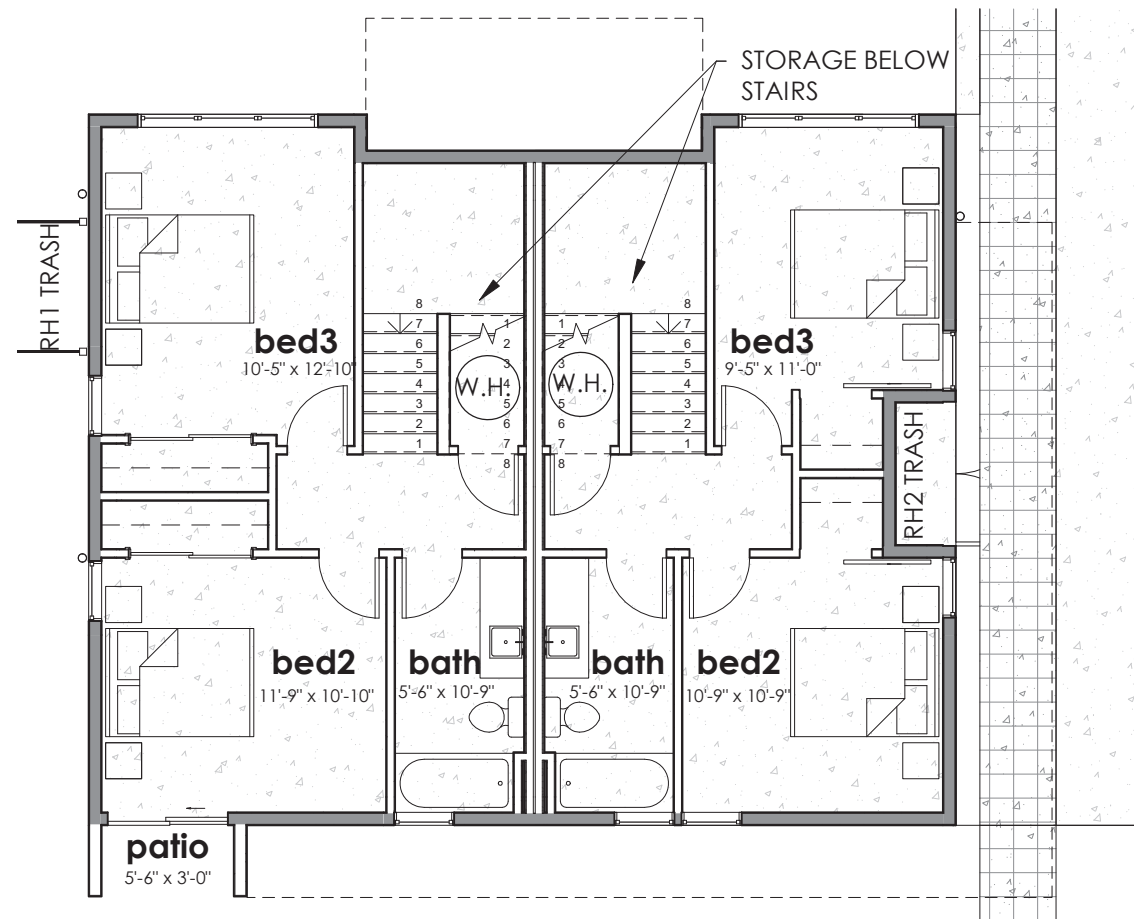

Level 1

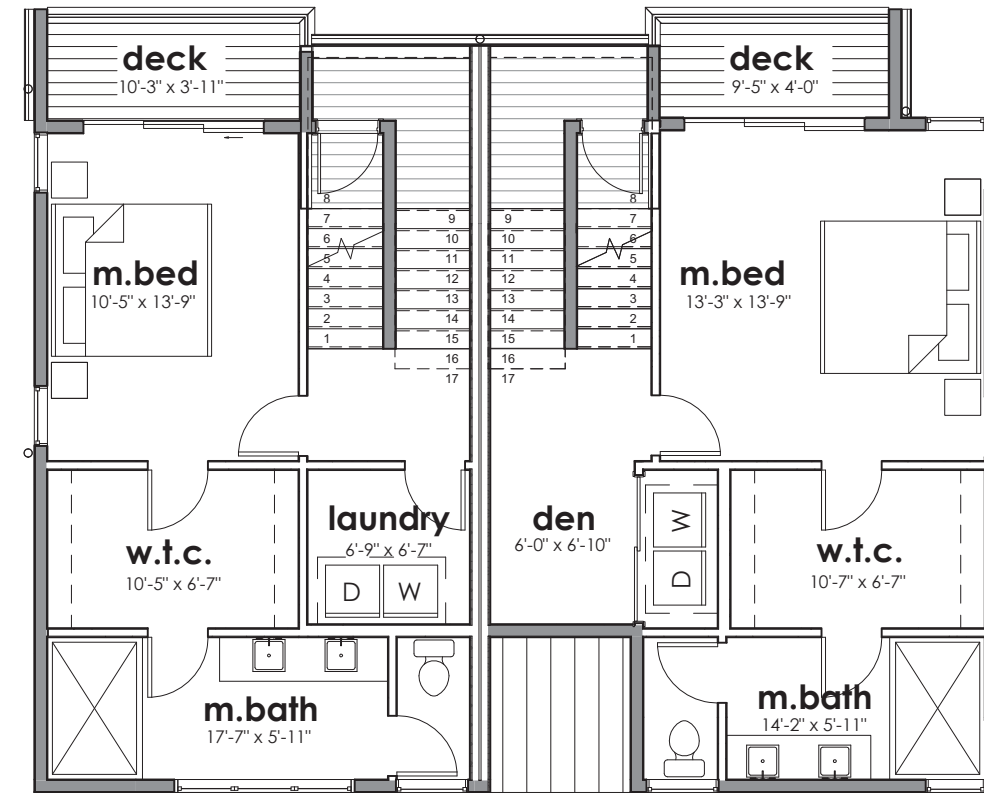

Level 3

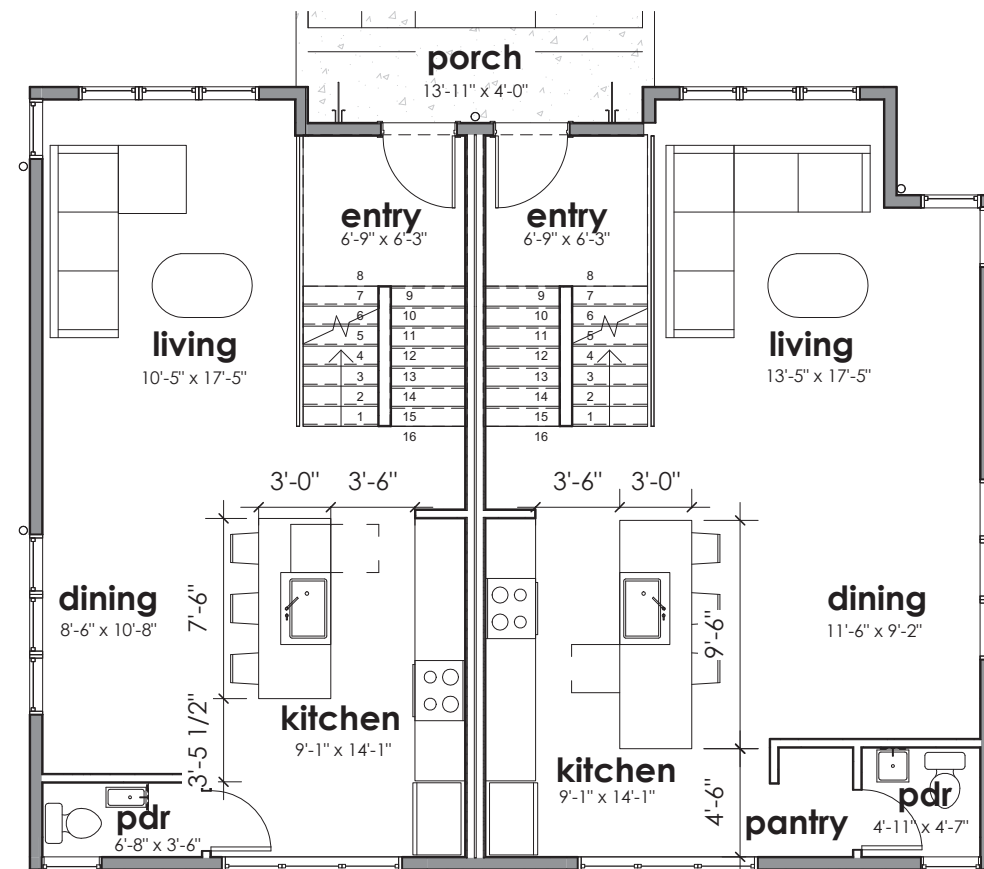

Level 2

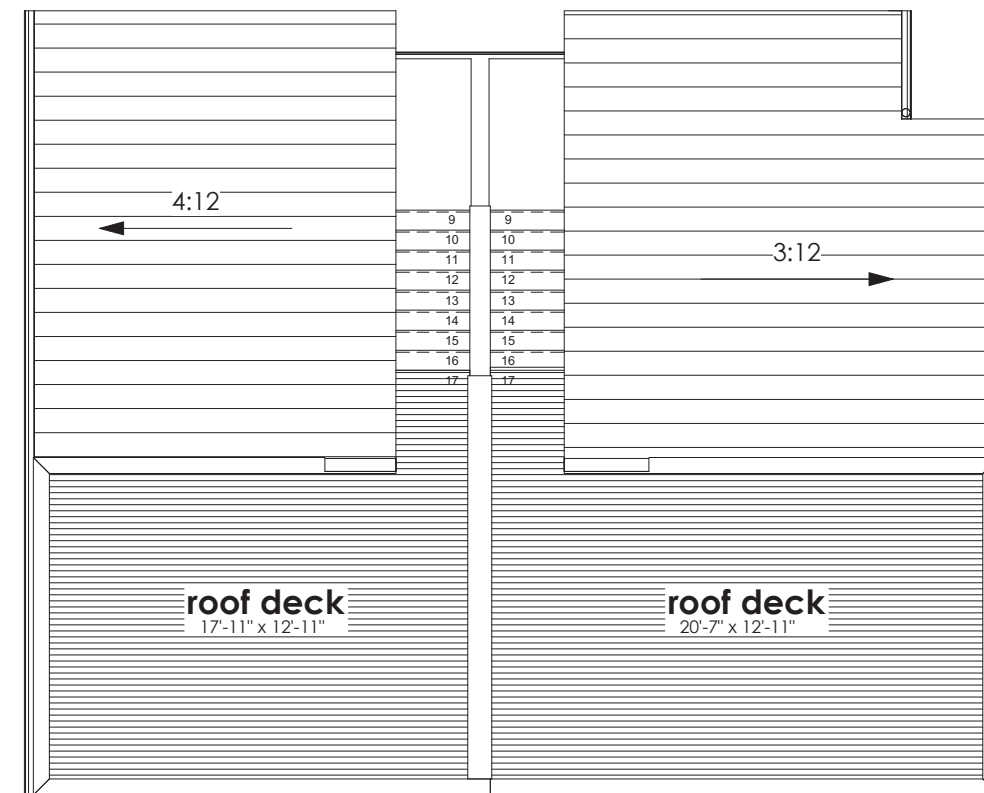

Roof deck



Scale: 1/8" = 1'0"

# Floor Plans - LOT A

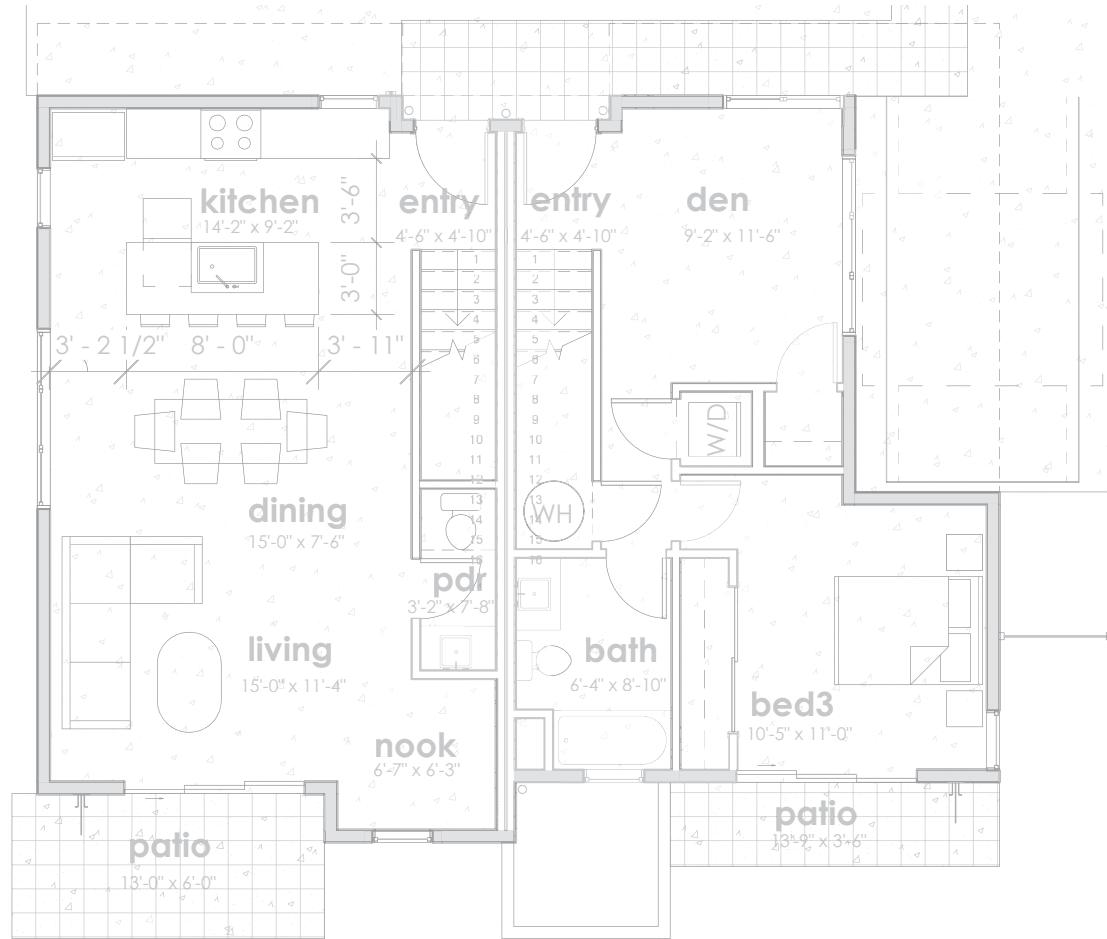

Level 1

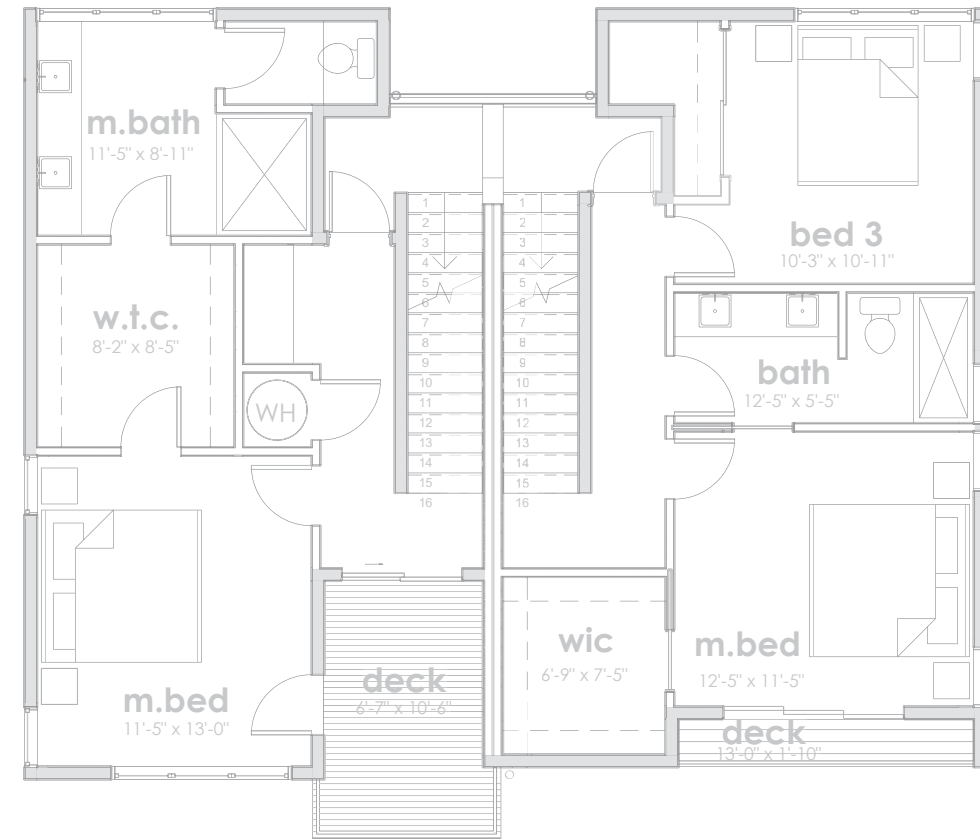

Level 3

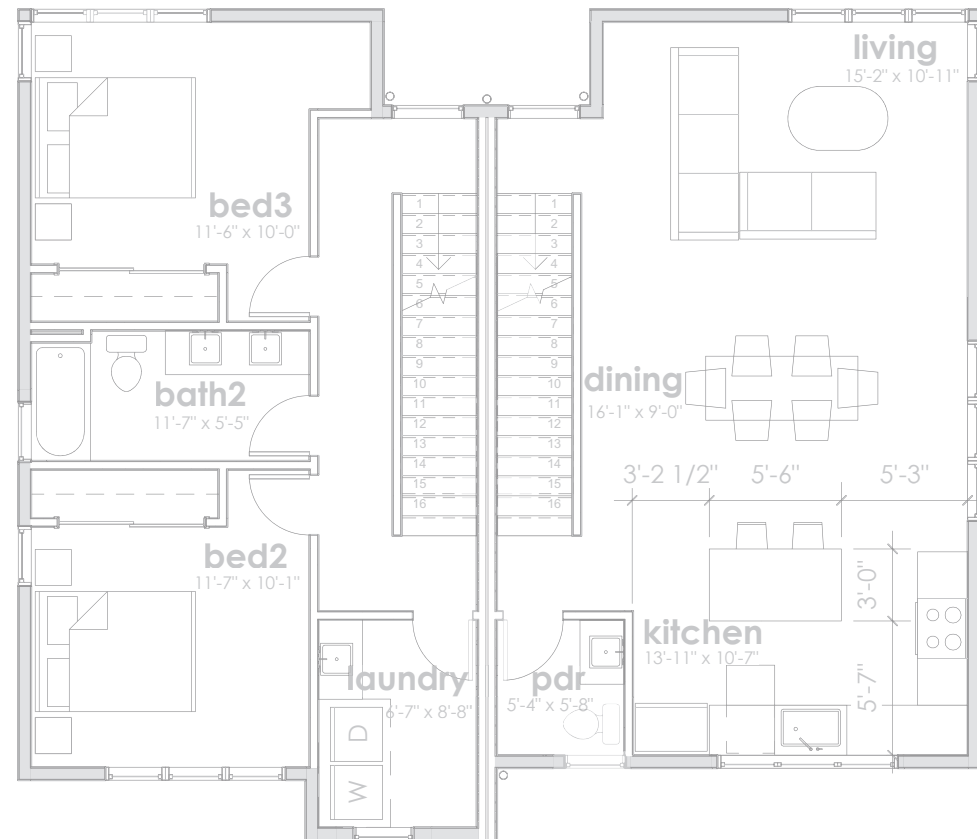

Level 2

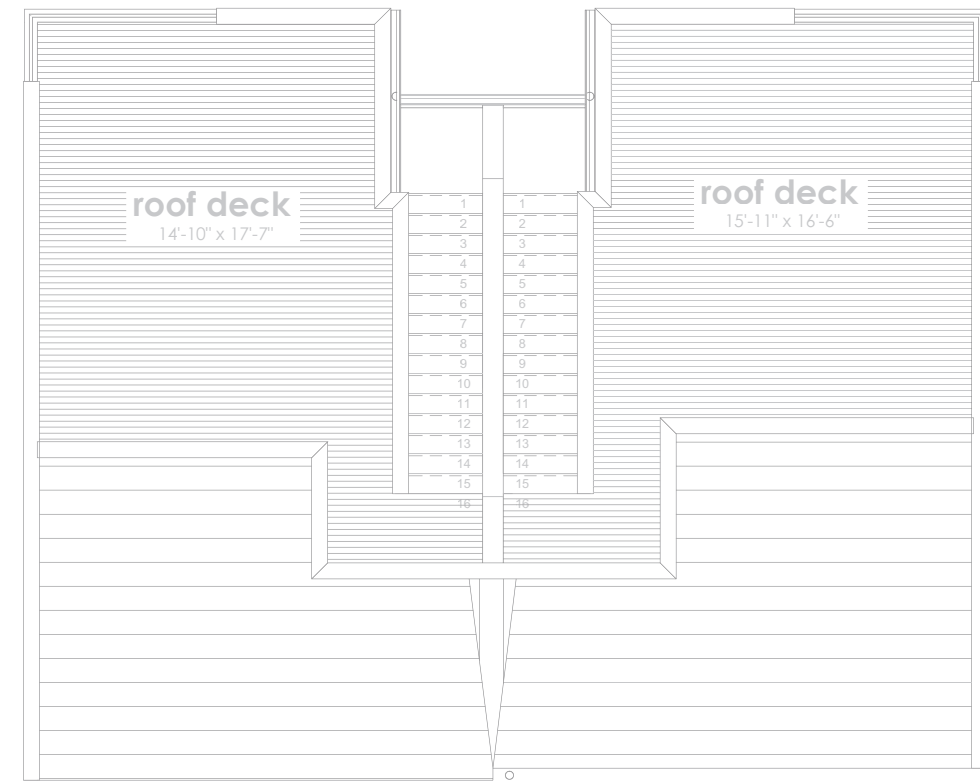

Roof deck

Scale: 1/8" = 1'0"

# Floor Plans - LOT B



### 1. Batten & Board

7.25" Hardie Mill Board on Batten

Dark Blue

Anchors Aweigh  
SW 9179

Base Material and Primary  
Material facing NW 60th St.

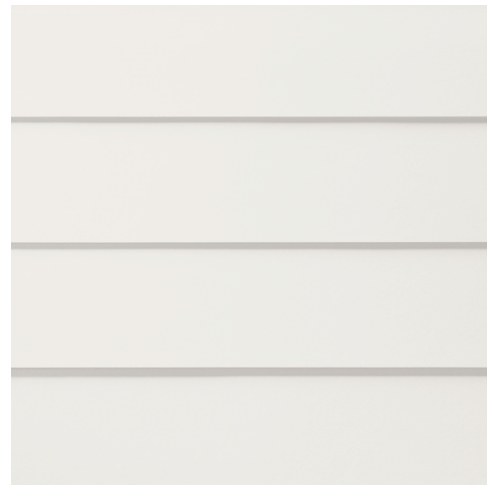

### 2. Lap Siding

7.25" Hardie Mill Lap Siding

White

Snowbound  
SW 7004

Upper Volumes

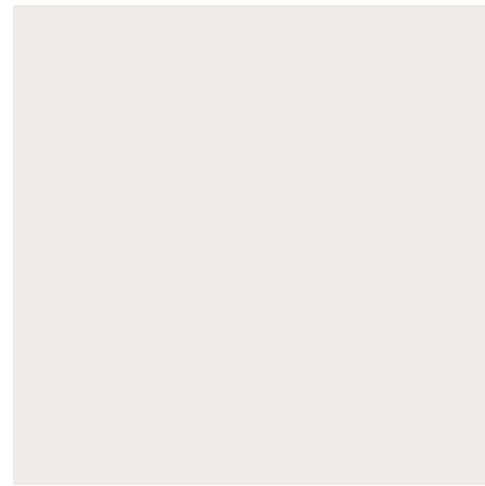

### 3. Cementitious Infill Panel

7/16" Hardie Cementitious Panel

White

Snowbound  
SW 7004

Infill Panel, and Roof Decks



### 4. Cedar T&G

1"x4" T&G Natural Cedar

Entries, Soffits and Covered  
Patios



### 5. Front Door

Wood and Glass Door Painted  
Red

Tanager  
SW 6601

Unit Entries



North Elevation (NW 60th St)



East Elevation



West Elevation



South Elevation



North Elevation (NW 60th St)



East Elevation



East Elevation



South Elevation



1.



2.



3.

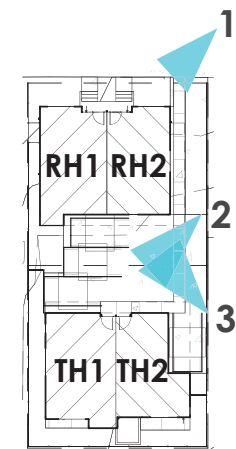



1.

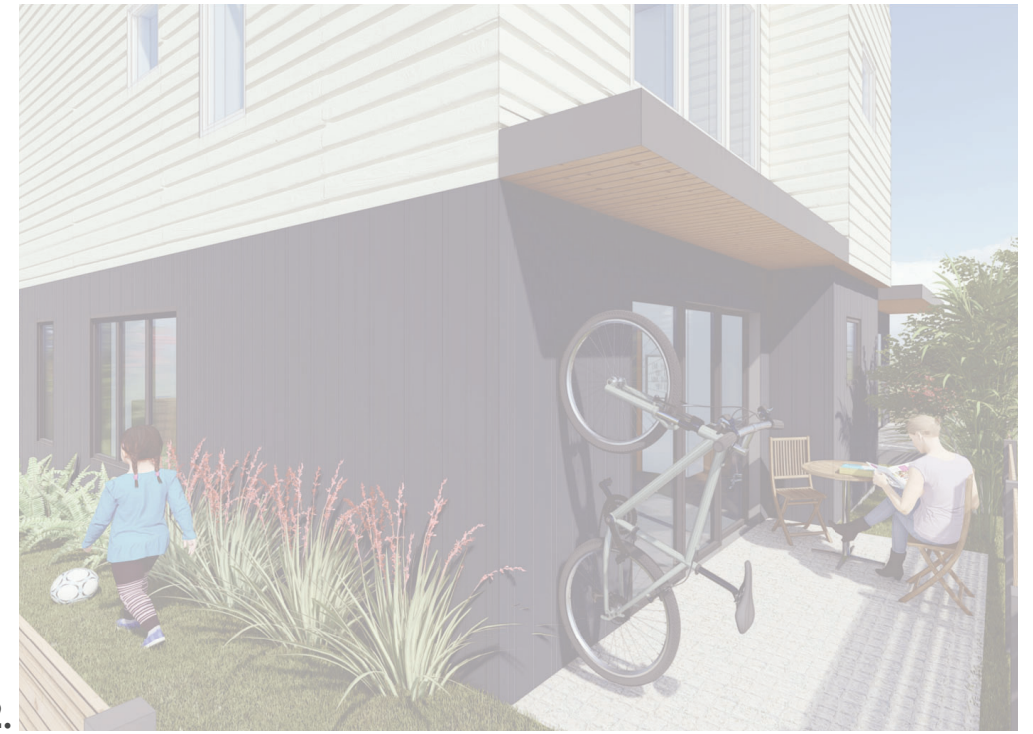

2.



3.

